

# **SIMMODEL: A DOMAIN DATA MODEL FOR WHOLE BUILDING ENERGY SIMULATION**

James O'Donnell<sup>1</sup>, Richard See<sup>2</sup>, Cody Rose<sup>1</sup>, Tobias Maile<sup>1</sup>, Vladimir Bazjanac<sup>1</sup>  
and Phil Haves<sup>1</sup>

<sup>1</sup>Lawrence Berkeley National Laboratory,  
Berkeley, CA, 94720 – U.S.A.

<sup>2</sup>Digital Alchemy Pro  
Seattle, WA, 98119 – USA

## **ABSTRACT**

Many inadequacies exist within industry-standard data models as used by present-day whole-building energy simulation software. Tools such as EnergyPlus and DOE-2 use custom schema definitions (IDD and BDL respectively) as opposed to standardized schema definitions (defined in XSD, EXPRESS, etc.). Non-standard data modes lead to a requirement for application developers to develop bespoke interfaces. Such tools have proven to be error prone in their implementation – typically resulting in information loss.

This paper presents a Simulation Domain Model (SimModel) - a new interoperable XML-based data model for the building simulation domain. SimModel provides a consistent data model across all aspects of the building simulation process, thus preventing information loss. The model accounts for new simulation tool architectures, existing and future systems, components and features. In addition, it is a multi-representation model that enables integrated geometric and MEP simulation configuration data. The SimModel objects ontology moves away from tool-specific, non-standard nomenclature by implementing an industry-validated terminology aligned with Industry Foundation Classes (IFC).

The first implementation of SimModel supports translations from IDD, Open Studio IDD, gbXML and IFC. In addition, the EnergyPlus Graphic User Interface (GUI) employs SimModel as its internal data model. Ultimately, SimModel will form the basis for a new IFC Model View Definition (MVD) that will enable data exchange from HVAC Design applications to Energy Analysis applications. Extensions to SimModel could easily support other data formats and simulations (e.g. Radiance, COMFEN, etc.).

## **INTRODUCTION**

The development of typical whole-building energy simulation models is time consuming and cumbersome (Hand et al., 2005). Re-use of existing data by interoperable processes would significantly reduce the time and overhead associated with the creation of simulation models (Bazjanac, 2001). However, a disconnect presently exists between related domains such as architectural, Mechanical Electrical Plumbing (MEP), life cycle costing and simulation. Only the IFC HVAC Interface to EnergyPlus currently exchanges HVAC information between IFC and a whole building energy simulation tool (Figure 1) (Bazjanac & Maile, 2004). Typical data exchange between professional tools is point to point. With regard to building geometry, simulation specialists typically receive 2D CAD drawings from the architect but must recreate the building model in their simulation tool. Further disconnects also exist between simulation domains and even between simulation tools in the same domain.

Rule based data transformations processes, if they adhere to the principles of information science, should preserve data integrity. Such processes transfer data from source applications via data adapters into data for target applications (Figure 1). Only one path presently exists for re-use of original building model (geometry) by other tools. The IFC HVAC Interface to EnergyPlus only supports HVAC information created in EnergyPlus. Sharing original data creates potential efficiencies in any given project. Whole building energy simulation, fire and safety, and day-lighting use similar but not identical building geometry descriptions but all domains must presently recreate the building in their own tools.

An interoperable, intelligent and object oriented simulation model would enable bi-directional data exchange with a Building Information Model (BIM) authoring applications. However typical simulation data models are stand-alone, usually in the form of non-object-oriented text files with poor or non-existent interfaces for data exchange. In fact, there is no official or de facto standard interface for the simulation domain. Existing simulation tools (E+, DOE-2, IES, etc.) require custom editing tools and fail to take advantage of standard data exchange tools that are available for data in XML, Standard for Exchange of Product models Part 21 (STEP) or other standard data exchange formats (ISO, 1994).

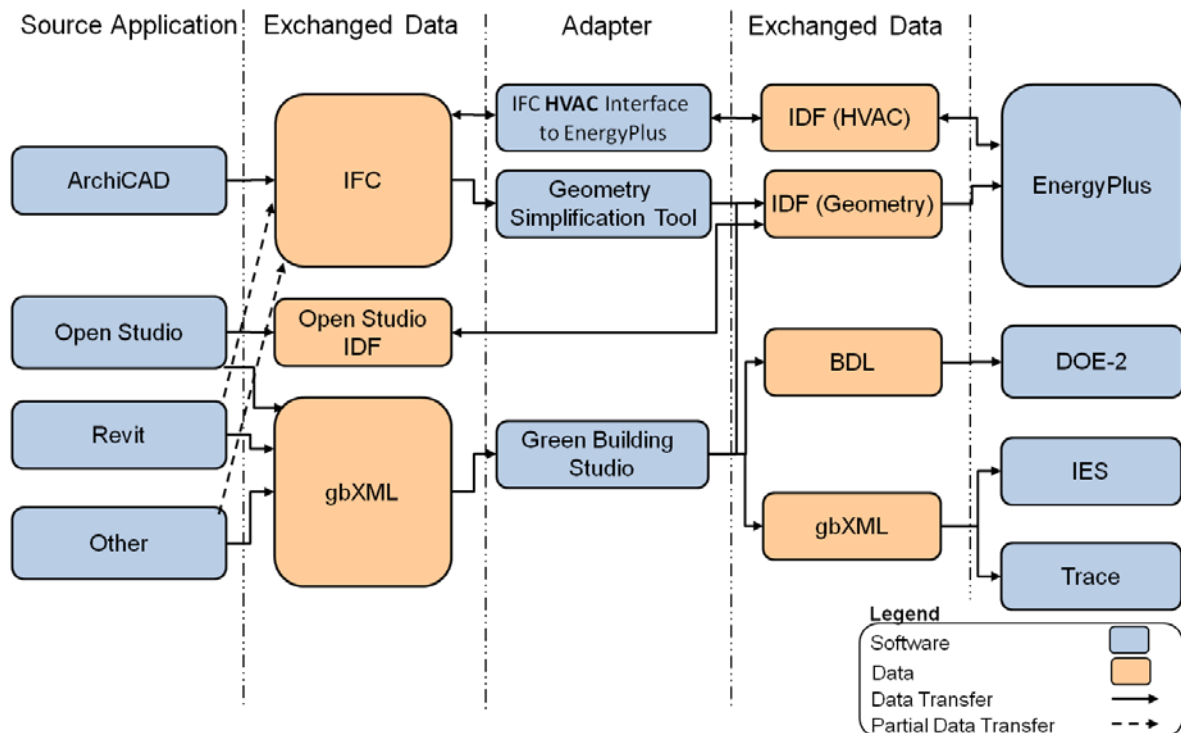

Figure 1: Limited extent of data exchange in the simulation domain, limited adapters to IFC inhibit interoperable data exchange

When compared to rigidly defined schemata, such as those developed in STEP, data models used by present day simulation tools are incomplete, inconsistent (therefore difficult to parse), contain errors and are editable by end users (ISO, 1994). They use position-based properties which are vulnerable to field insertion, deletion and re-ordering. With regard to specific properties, popular data models (EnergyPlus, DOE-2) only use three basic data types: string, integer and real. For properties that repeat N times, these models store each instance as a separate property instead of using lists or other more efficient data structures. Present simulation data models are flat as they fail to represent detailed topologies and aggregate data types such as a system that can contain sub-systems and components. Even fundamental parent-child relationships, that most end user tools could leverage, are not modelled.

These custom schema definitions mean other application developers must develop bespoke interfaces in order to load the data. Use of formal schema definition formats like XML Schema Definition (XSD) or EXPRESS enable application developers to use toolboxes that do the 'heavy lifting' of parsing and loading those data into memory. The application developer can then access data through a straightforward Application Programming Interface (API). For example, an XML-based interface would maintain backwards compatibility across field insertion, reordering and deprecation.

More recent exchange models, such as gbXML, enable the exchange of concepts previously defined in BDL and IDD using XML (gbXML, 2010). It supports one-directional data flow from CAD to simulation tools but applications typically focus on geometric data. In fact, very few applications support HVAC information defined in gbXML. In addition, gbXML includes support for 1st and 2nd level space boundaries but does not address 3rd, 4th or 5th level space boundaries as defined by Bazjanac (2010). It also fails to preserve geometric relationships as are defined in IFC. Documentation contained within the gbXML schema is uneven at the element level and ambiguous in places. For example, gbXML does not meet CEC definition requirements for definition of windows (Barnaby, 2008). These issues make the schema difficult to understand and introduce the risk of alternative interpretations by different application vendors looking to support gbXML.

IFC was also considered as a new generation data model for simulation but it has a number of limitations when considering the needs of simulation applications. Most notably, IFC doesn't support many specialized concepts in EnergyPlus IDD. Due to these limitations, a direct mapping between IFC and IDD was deemed impractical.

With all of these considerations in mind, the simulation domain requires a new interoperable data model that facilitates:

- Import of data from existing simulation tools
- Export of relevant data to existing simulation tools
- Bi-directional exchange of data with interoperable BIM thus enabling the re-use of original data in simulation

The following sections outline the objectives, proposed uses, concepts and content of a proposed data model for the simulation domain. An example implementation imports and exports the full set of example files that ship with the EnergyPlus software. The future work proposes a direction for this domain data model. The ideal objective would have SimModel absorbed into the IFC data model.

### SIMMODEL OBJECTIVES

This paper presents a Simulation Domain Model (SimModel) - a new interoperable XML-based data model for the building simulation domain. SimModel considers data sharing for two generic use cases (Figure 2):

- 1) Within the building simulation domains
- 2) Within the overall Architecture/ Engineering/ Construction/ Owner/ Operator (AECOO) industry

The objective of the former is to seamlessly import and export data relevant to EnergyPlus and other simulation software developed by the various United States Department Of Energy (DOE) Laboratories. The model is easily extensible to support additional software as interfaces are developed for these software.

In the case of the latter objective, SimModel must maintain compatibility with mainstream BIM software used in the building industry (e.g. Autodesk Revit, Graphisoft ArchiCAD and Beck Technologies dProfiler). Instead of recreating building data in numerous software packages, SimModel must map to an industry standard BIM to enable direct use of original building model design data, for example architecture MEP, costing and others (Figure 2). In any given project data may only be relevant to a particular stakeholder (unshared data) or to many stakeholders (shared data) (Figure 2). Simulations other than energy performance simulation also commonly use large amounts of geometric and HVAC data. Examples include lighting analysis, fire analysis, acoustic analysis, CFD analysis and code checking.

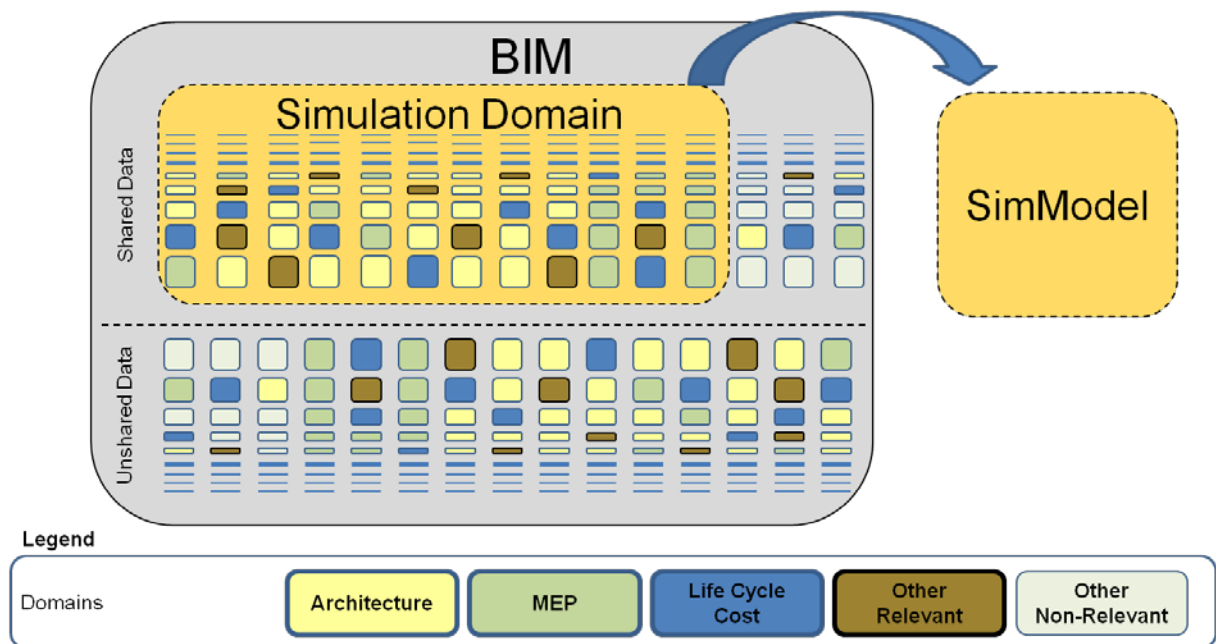

Figure 2: SimModel represents a specific sub-set of shared information as used by the simulation domain.

Momentum is gathering with respect to IFC based sharing of project data. Between 2007 and 2010 three large building owners (GSA in USA, Statsbygg in Norway, and Senate Properties in Finland) defined an IFC Model View Definition (MVD) to standardize building model data for use in energy analysis. This MVD, named 'Concept design BIM 2010' (CDB-2010) (buildingSMART, 2011), provides the ideal basis for data exchange between standard BIM applications and SimModel because the three mentioned large owners will begin requiring it in their projects starting in 2012. The starting point for SimModel was the harmonization of concepts in CDB-2010 and IDD.

HVAC systems require a unique representation for analysis in whole-building energy simulation programs. The important concepts are containment, connectivity, heat sources, and heat sinks. With respect to containment, the model structure must also facilitate system to sub-system or system to zone relationships.

Other key relationships link heat sources and heat sinks. For example, thermal zones are served by air systems, water systems, or both air and water systems. Similarly hot and chilled water plant loops serve built-up air systems. Furthermore, the connections between HVAC components and the direction of flow are also necessary. Conversely, physical equipment locations are presently irrelevant as are duct and piping layouts (a functional

limitation of simulation tools). Another objective in the development of SimModel was to look to future requirements for the simulation domain. Such requirements include additional features within existing simulation tools, new simulation tools and, most importantly, new flexible simulation architectures. Users require tools that accurately model bi-directional flow in low energy systems as opposed to present tools that confine users to either rigid architectures or architectures that, while flexible, contain limited building geometry descriptions.

Terminology may also cause confusion when exchanging data among different domains. Therefore, the nomenclature required by a simulation domain model should adhere to standard descriptions used across the building industry as opposed to arcane descriptions adopted by popular simulation data models. In theory, an unambiguous nomenclature would reduce overhead associated with other future mappings to a specifically designed simulation data model SimModel.

The structure, content and features of a new simulation-domain data model (SimModel) now reflect the previously outlined objectives.

## SIMMODEL DESIGN

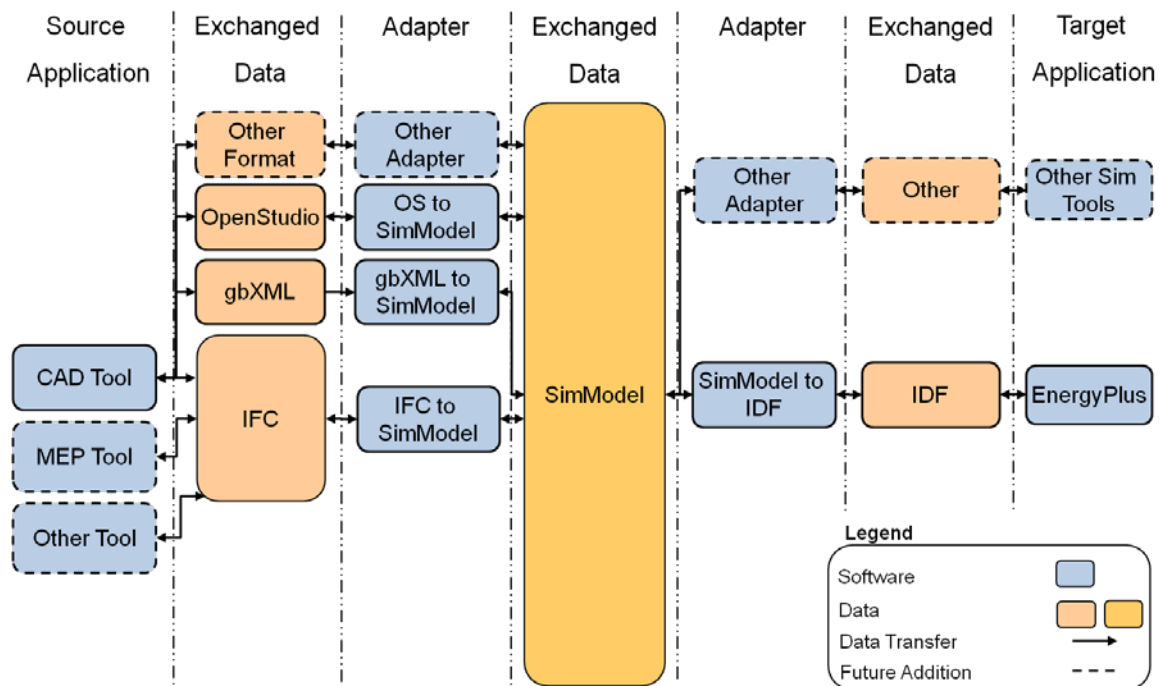

Figure 3: Interoperable data exchange enabled by SimModel. This solution enables re-use of original project data as contained in IFC based BIM (bi-directional mapping) and data from other sources (import only)

SimModel incorporates a number of features to address current domain weaknesses (as highlighted in the introduction), a set of requirements for a shared simulations model (as presented in SimModel Objectives) and is easily extensible to account for future domain advances. It ensures interoperable exchange of simulation data within the simulation domain and most importantly across an entire building project. The unique design enables interoperable data exchange and uses a number of features to do so. These are:

- Mappings to/from existing domain models
- Structured yet flexible class definitions
- Property set definitions
- Object type definitions
- Model Ontology
- Model Topology
- Templates
- Resources
- Representation context
- Outputs

The following subsections detail the key features.

## Data model mappings

The data model should facilitate seamless data exchange for the extended building-simulation domain and even for the entire AECOO industry (Figure 3). Version 1.0 supports BIM concepts from IFC, gbXML, IDF, and OpenStudio (NREL, 2010). The quality of data varies with each file format so customized adapters enable single or bi-directional mappings on a case-by-case basis. SimModel can also accommodate bi-directional mapping to other data models as the need arises, e.g. IDA ICE or IES.

## Class definitions

Data element/entity ontologies vary greatly between SimModel, IDD and gbXML. The EnergyPlus IDD contains ~650 element types and other relevant data model schemas, as illustrated in (Figure 3), contain several hundred classes. SimModel uses approximately 120 data model classes to represent the merger of EnergyPlus IDD and other model schemas. This approach results in fewer software classes, less code to maintain and simplified model evolution.

The streamlined approach uses a type/subtype hierarchy for each data model class. An example best illustrates this concept. SimFlowMover is a data model class that represents fans and pumps. However pumps and fans are types within that class, where each type then contains the relevant subtypes, e.g. class = SimFlowMover, type = Fan, subtype = VariableVolume.

The type/subtype approach also acts as a filter for data on an object instance to ensure that only properties relevant to the subtype are used. Table 1 contains an example of the SimModel class/type/subtype mapping for the IDD fans group. This approach enables schema evolution and application specific schema variants.

## Properties

Many IDD objects do not map to a SimModel class/type/subtype. Instead, they map as additional properties that supplement another class/type/subtype mapping, e.g. FanPerformance:NightVentilation, an IDD object, is intended as an add-on for the other fan definitions and is therefore mapped as extra properties for fans defined in other IDD elements (Table 1).

At the property level, the model uses an extended set of data types. This enables a precise definition of an individual datum or sets of data. In addition, the model includes lists and aggregated data types. Finally, groups of properties associated with a single SimModel object are flexible and extensible.

## Object Type Definitions

To further enhance efficiency, SimModel supports the concept of object type definition (as found in the IFC model) in which a standard type is defined once and many object instances reference that definition. **Model Ontology**

The SimModel ontology introduces two concepts that were previously undefined in simulation data models: projects and design alternatives (Figure 4). These new concepts enable an efficient re-use of existing data and minimize the overhead associated with tracking changes between design alternatives. Other features include geometric entities, HVAC systems, HVAC components, groups, controls, simulation parameters, and outputs (Figure 4). The concept of modeling systems and zones as groups is unique when compared with other data models in the simulation domain. This feature aligns with the definition of Thermal Blocks as contained in COMNET (a set of rules and procedures for energy modeling) (RESNET, 2010). Explicitly defined properties enable collections of group members. SimModel also surpasses IFC with respect to loosely defined building element assemblies. It formalizes definitions for curtain walls, ramps, roofs, stairs, transportation systems, site assemblies, day-lighting assemblies and ventilation assemblies.

Table 1: Example mapping of IDD objects to SimModel

IDD Object	SimModel Class	Type	Sub-Type
Fan:ConstantVolume	SimFlowMover	Fan	ConstantVolume
Fan:VariableVolume	SimFlowMover	Fan	VariableVolume
Fan:OnOff	SimFlowMover	Fan	OnOff
Fan:ZoneExhaust	SimFlowMover	Fan	ZoneExhaust
FanPerformance:NightVentilation	SimFlowMover	Fan	(Add as props for all)
Fan:ComponentModel	SimFlowMover	Fan	ComponentModel

## Model Topology

Formalized concepts for topological relationships support modeling of distribution systems (like HVAC) in SimModel. Supported representations include explicit port types such as air-inlet or chilled water outlet and

connections such as pipes or ducts. The alternative would include port definitions as part of an object definition and connections through a referencing mechanism between ports. Ports explicitly link to the elements they serve and connection elements know the ports they connect to. These concepts go beyond their counterparts in IFC, as IFC does not support ports on zones or spaces. Applications may in turn easily establish direction of flow based on these concepts.

### Templates

Templates are another key feature that empower users and allows them to leverage pre-configured data sets and configurations (Figure 4), thus expediting simulation model development. Templates should, where possible, reference lower level data contained in libraries. Such referencing ensures standard configurations of data that result in fewer problems in simulation runs than a less rigid approach. For example, a template for an air system may select a fan and a heating coil from their respective libraries.

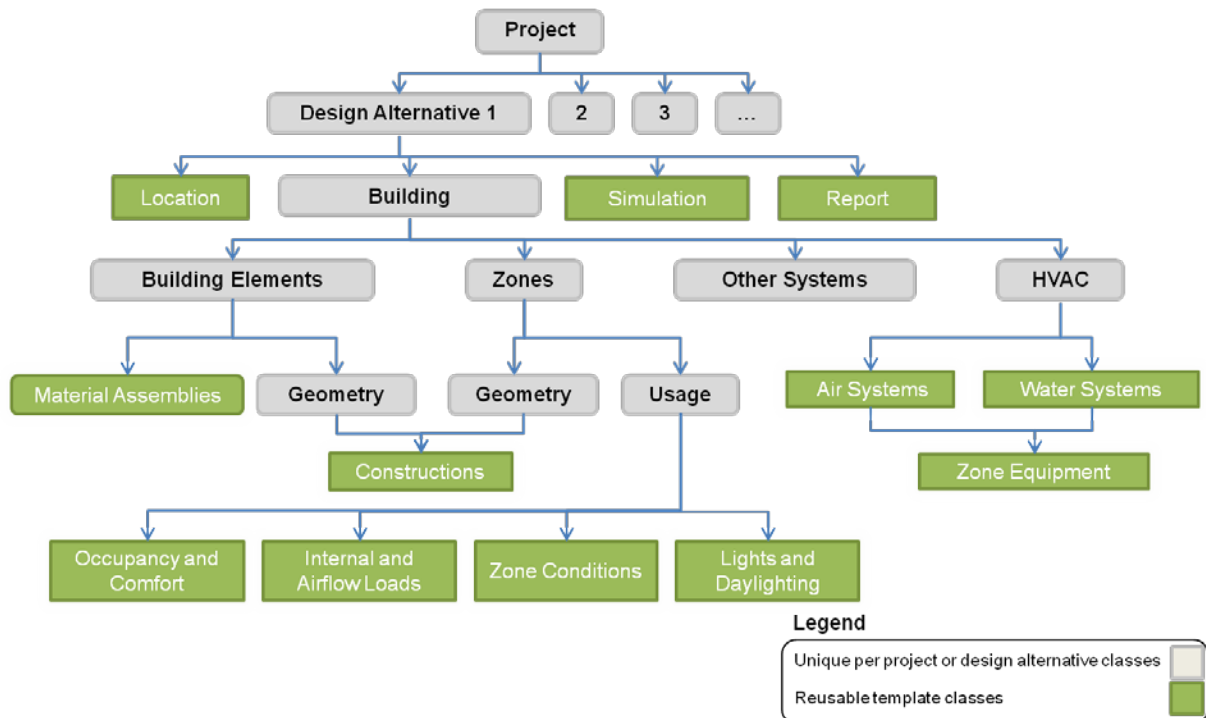

Figure 4: SimModel class hierarchy illustrating the relationships between the key facets of a simulation model. Preconfigured and reusable data sets called templates enable faster model development

Templates do not impede flexibility in projects. Users may override values stored in the template with local values and in turn save the new configuration as new template.

### Resources

SimModel takes advantage of a number of resource objects that are absent from other simulation domain data models. These include actors in a project, which can include people, organizations, or people in organizations (as in IFC). Examples that have come into SimModel from CDB-2010 include the building owner, the architect, and building occupants. Actors are also used to support the fact that simulation tools require not only heat generated by occupants but also their behavior and presence. For the purposes of collaboration, applications may also associate an actor with the ownership of each individual object instance (called the OwnerHistory – as in IFC).

### Representation Context

SimModel also uses the concept of representation context which means it is a multi-representation model. End users may access objects in different contexts, such as plan view, 3-d or cross section, similar to an intelligent CAD tool. Energy simulation requires analytical representations which support and compliment the physical shape representations. SimModel supports both. In practice, simulation specialists may use both hierarchical (systems) and topological (components and connections) representations for HVAC Systems, both of which compliment graphical representations that may be associated with component type definitions.

### Outputs

Post-processing of simulation output is most important as simulation engines may generate enormous amounts of output data. SimModel output mappings reflect the breadth and depth of present output formats and output requests contained in EnergyPlus. The chosen approach stores a set of inputs that enable a user to recreate

identical outputs for a particular model. SimModel therefore stores a link (URL) to simulation outputs with simulation run data as opposed to explicitly storing output data within a model instance. To ensure consistency when rerunning simulations, simulation configurations data is also structured and stored for re-use.

End users of the forthcoming EnergyPlus GUI (See et al., 2011) may configure and save output format and output request sets as SimModel Templates. Simulation modelers may then re-use data across multiple design alternatives and projects.

### USING SIMMODEL

SimModel, like any other data model, requires rigorous testing. The initial test process uses the 391 example and dataset files that ship with EnergyPlus Version 6. The objective is to maintain data fidelity across the following process:

1. Import each file
2. Evaluate its SimModel representation
3. Export from SimModel to a new file
4. Compare the original file with a new file

The testing environment uses an import and export process to ensure a schema-mapping driven approach for import and export of IDD data (Figure 5). Leveraging a defined cross-schema mapping between IDD and SimModel minimizes the need for import and export software.

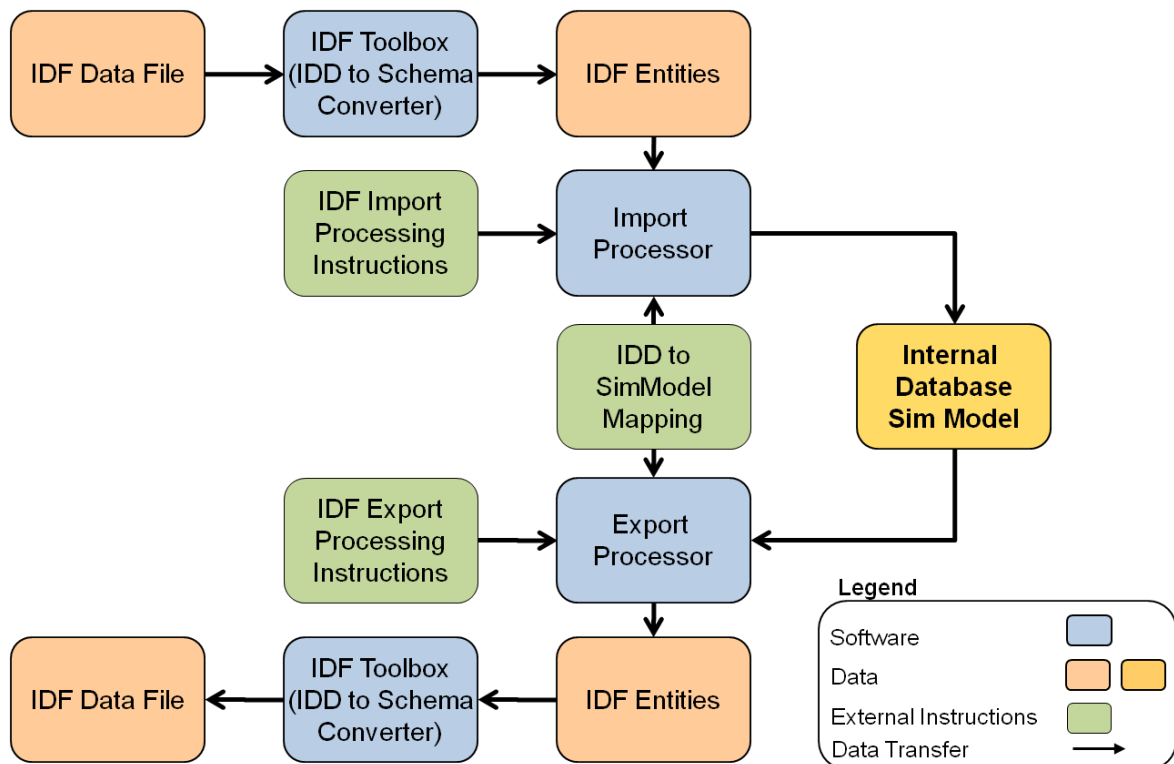

*Figure 5: Bi-directional mapping process (import and export) for IDF data to SimModel. Similar import-export processes would evaluate data exchange between other data models and SimModel*

Within this environment the IDF toolbox provides structured access to IDF data by creating an object based representation of IDF entities as contained in each testing file.

The testing process uncovered a number of issues with SimModel (IDF entities mapped as add props are not mapped if the parent object is not included in the IDF file) and even in some of the IDF files (duplicate entries or incorrect property names). Outstanding issues include:

- Parametric entities that SimModel does not presently support
- Combined string and enumeration fields in IDD
- Data set files that contain multiple entities of the same type with the same name

As of writing this paper the testing process reports zero errors for 95% of the example files. A similar process will apply in testing import and export of other file formats to SimModel.



## CONCLUSIONS AND FUTURE WORK

The development of SimModel, an interoperable, structured and yet easily extensible data model, enables improved inter-disciplinary data exchange within the simulation domain. This model leverages original data (such as the building geometry as defined by an architect) in whole building energy simulation, CFD, fire and safety simulation and others. Re-use of geometric and other data from different models significantly reduces the overhead associated with the definition of input data and has the potential to eliminate error-prone manual processes. Library and template entries for HVAC equipment and systems also reduce time spent searching through manufacturers' catalogues and the potential for erroneous input. Simulation specialists can therefore focus on additional design alternatives or enhance the quality of a particular simulation.

The structured nature of SimModel also benefits simulation tool developers. The rigidly defined schema allows for a relatively easy transition between versions of the model, thus significantly reducing the manual effort of a development team and giving simulation tool developers additional time to focus on simulation architectures and feature development.

SimModel content is available for review at (LBNL, 2011). The SimModel XSD is quite large and will be available for download in 2012. Future work may decompose this schema into numerous smaller XML schemata with an accompanying parent schema. Software developers commonly prefer to deal with smaller sections as opposed to a single giant schema (buildingSmart, 2010). An example of such an approach is the SABLE project in which the SABLE Server supported an extensive schema for data model integration and various application domain specific API's for access to data (SABLE, 2005).

Radiance, COMFEN, WINDOW, THERM and others should also develop bi-directional mappings between SimModel and application specific data models. In order for SimModel to influence the larger AECOO industry it must provide mapping to the industry standard data model for interoperability, IFC. This will take the form of one or more IFC MVDs. The most important of which is an MVD for detailed HVAC systems used by whole building energy simulation tools. This MVC would complement CDB-2010. The EnergyPlus GUI product will import and export these MVDs directly. This ensures that compliant interoperable software would correctly transfer data from one such application to SimModel and is then accessible by another. This work - MVD BSA-002 - is underway as part CDB-2010 (buildingSMART, 2011).

Additional future work will also add to SimModel. Common concepts used in legislative requirements, such as California Title 24 or ASHRAE 90.1 are a priority. Such concept additions will facilitate assessment of design alternatives relative to legislative requirements.

Catalogues of equipment data are presently non-standardized and ASHRAE PC 205 aims to define a standard format for HVAC components (Barnaby, 2011). Data to populate this standard could come from the forthcoming NREL component model. A storage mechanism such as the International Framework for Dictionaries (IFD) will facilitate widespread adoption (IFD, 2007). These data accessed through a standard format will map seamlessly to the SimModel entity types and will therefore be accessible to the simulation profession.

## ACKNOWLEDGEMENTS

The work described in this report was funded by the California Energy Commission, Public Interest Energy Research (PIER) program, under Contract No. 500-90-010, and was partly supported by the Assistant Secretary for Energy Efficiency and Renewable Energy, Office of Building Technology, Building Technologies Program of the U.S. Department of Energy under Contract No. DE-AC02-05CH11231.

The authors would also like to thank Dr. Elmer Morrissey for objectively reviewing the content of this paper.

## REFERENCES

- Barnaby, C. (2011) ASHRAE SPC-205 Data Exchange Protocols for Energy Simulation of HVAC&R Equipment Performance.
- Barnaby, C. (2008) gbXML from a Developers Point of View.
- Bazjanac, V. (2001) Acquisition of Building Geometry in the Simulation of Energy Performance. In: *Building Simulation 2001, 7th International IBPSA Conference, Rio de Janeiro*. Rio de Janeiro, International Building Performance Simulation Association.
- Bazjanac, V. (2010) Space boundary requirements for modeling of building geometry for energy and other performance simulation. In: *CIB W78: 27th International Conference*. Cairo, Egypt.
- Bazjanac, V. & Maile, T. (2004) *IFC HVAC Interface to EnergyPlus - A Case of Expanded Interoperability for Energy Simulation*.
- buildingSmart (2010) Coordination View Version 2.0 Summary — buildingSMART technical resources [Internet]. Available from: <[http://www.iai-tech.org/products/ifc\\_specification/ifc-view-definition/coordination-view](http://www.iai-tech.org/products/ifc_specification/ifc-view-definition/coordination-view)> [Accessed 7 April 2011].



- buildingSMART (2011) IFC Solutions Factory, The Model View Definition Site [Internet]. Available from: <<http://www.blis-project.org/IAI-MVD/>> [Accessed 8 March 2011].
- gbXML (2010) *Open Green Building XML*. Available from: <[www.gbxml.org](http://www.gbxml.org)>.
- Hand, J.W., Crawley, D.B., Donn, M. & Lawrie, L.K. (2005) Improving the Data available to Simulation Programs. In: *Proceedings of Building Simulation 2005*. Montreal Canada, IBPSA, pp.373-380.
- IFD (2007) International Framework for Dictionaries [Internet]. Available from: <[http://www.ifd-library.org/index.php?title=Main\\_Page](http://www.ifd-library.org/index.php?title=Main_Page)> [Accessed 8 March 2011].
- ISO (1994) ISO-10303-Part 21. ISO-10303-1 [Internet]. Available from: <<http://www.steptools.com/library/standard/>> [Accessed 8 March 2011].
- LBNL (2011) Simulation Data Model [Internet]. Available from: <<http://simmodel.dyndns.org/>>.
- NREL (2010) NREL: OpenStudio [Internet]. Available from: <<http://openstudio.nrel.gov/>> [Accessed 7 April 2011].
- RESNET (2010) *Commercial Buildings Energy Modeling Guidelines and Procedures*. Available from: <[www.comnet.org](http://www.comnet.org)>.
- SABLE (2005) *Simple Access to Building Life Cycle Exchange*. Available from: <<http://www.blis-project.org/~sable>>.
- See, R., Haves, P., Sreekanthan, P., Basarkar, M., O'Donnell, J. & Settlemeyre, K. (2011) Development of a user interface for the EnergyPlus whole building energy simulation program. In: *IBPSA Building Simulation 2011. Sydney, Australia*. Sydney, Australia, IBPSA.