

ERNEST ORLANDO LAWRENCE BERKELEY NATIONAL LABORATORY

Building Energy Monitoring and Analysis

Tianzhen Hong¹, Wei Feng¹, Alison Lu¹,
Jianjun Xia², Le Yang², Qi Shen²,
Piljae Im³, Mahabir Bhandari³

¹Environmental Energy Technologies Division, LBNL

² Department of Building Science and Technology, Tsinghua
University, China

³ Building Technologies Research and Integration Center, ORNL

June 2013

Disclaimer

This document was prepared as an account of work sponsored by the United States Government. While this document is believed to contain correct information, neither the United States Government nor any agency thereof, nor The Regents of the University of California, nor any of their employees, makes any warranty, express or implied, or assumes any legal responsibility for the accuracy, completeness, or usefulness of any information, apparatus, product, or process disclosed, or represents that its use would not infringe privately owned rights. Reference herein to any specific commercial product, process, or service by its trade name, trademark, manufacturer, or otherwise, does not necessarily constitute or imply its endorsement, recommendation, or favoring by the United States Government or any agency thereof, or The Regents of the University of California. The views and opinions of authors expressed herein do not necessarily state or reflect those of the United States Government or any agency thereof, or The Regents of the University of California.

Ernest Orlando Lawrence Berkeley National Laboratory is an equal opportunity employer.

Please cite this report as follows:

Hong, T., Feng, W., Lu, A., Xia, J., Yang, L., Shen, Q., Im, P., Bhandari, M. Building energy monitoring and analysis. Lawrence Berkeley National Laboratory, June 2013. LBNL-6640E.

Acknowledgement

This report is a summary of research work conducted by LBNL, Tsinghua University, China, and ORNL in 2011 and 2012 under the 5-year research program of the U.S.-China Clean Energy Research Center for Building Energy Efficiency (CERC-BEE).

The LBNL's research was supported by the Assistant Secretary for Energy Efficiency and Renewable Energy of the U.S. Department of Energy under Contract No. DE-AC02-05CH11231. The ORNL's research was supported by the Assistant Secretary for Energy Efficiency and Renewable Energy of the U.S. Department of Energy. Tsinghua's research was supported by the Ministry of Housing and Urban-Rural Development and the Ministry of Science and Technology of China, under Contract No. 2010DFA72740-02.

Special thanks to the U.S. and China CERC-BEE management, our industry partners, the Industry Advisory Board, and the Technical Advisory Committee for the strong support on the project.



Executive Summary

U.S. and China are the world's top two economies. Together they consumed one-third of the world's primary energy. It is an unprecedented opportunity and challenge for governments, researchers and industries in both countries to join together to address energy issues and global climate change. Such joint collaboration has huge potential in creating new jobs in energy technologies and services.

Buildings in the US and China consumed about 40% and 25% of the primary energy in both countries in 2010 respectively. Worldwide, the building sector is the largest contributor to the greenhouse gas emission. Better understanding and improving the energy performance of buildings is a critical step towards sustainable development and mitigation of global climate change.

This project aimed to develop a standard methodology for building energy data definition, collection, presentation, and analysis; apply the developed methods to a standardized energy monitoring platform, including hardware and software, to collect and analyze building energy use data; and compile offline statistical data and online real-time data in both countries for fully understanding the current status of building energy use. This helps decode the driving forces behind the discrepancy of building energy use between the two countries; identify gaps and deficiencies of current building energy monitoring, data collection, and analysis; and create knowledge and tools to collect and analyze good building energy data to provide valuable and actionable information for key stakeholders.

Key research findings were summarized as follows:

1. Identified the need for a standard data model and platform to collect, process, analyze, and exchange building performance data due to different definitions of energy use and boundary, difficulty in exchanging data, and lack of current standards.
 2. Compared energy monitoring systems to identify gaps, including iSagy, Pulse Energy, SkySpark, sMap, EPP, ION, and Metasys.
 3. Contributed to develop a standard data model to represent energy use in buildings (ISO standard 12655 and a Chinese national standard)
 4. Determined that buildings in the United States and China are very different in design, operation, maintenance, occupant behavior: U.S. buildings have more stringent comfort standards regarding temperature, ventilation, lighting, and hot-water use and therefore higher internal loads and operating hours, and China buildings having higher lighting energy use, seasonal HVAC operation, more operators, more use of natural ventilation, less outdoor ventilation air, and wider range of comfort temperature.
 5. Completed data collection for six office buildings, one in UC Merced campus, one in Sacramento, one in Berkeley, one in George Tech campus, and two in Beijing.
-

6. Compiled a source book of 10 selected buildings in the United States and China with detailed descriptions of the buildings, data points, and monitoring systems, and containing energy analysis of each building and an energy benchmarking among all buildings.
7. Recognized limited availability of quality data, particularly with long periods of time-interval data, and general lack of value for good data and large datasets.
8. Compiled a building energy database, with detailed energy end use at 1-hour or 15-minute time interval, of six office buildings – four in the U.S. and two in China. The database is available to the public and is a valuable resource for building research.
9. Developed methods and used them in data analysis of building performance for the five buildings with adequate data, including energy benchmarking, profiling (daily, weekly, monthly), and diagnostics.
10. Recommended energy efficiency measures for building retrofit in both countries. U.S. buildings show more potential savings by reducing operation time, reducing plug-loads, expanding comfort temperature range, and turning off lights or equipment when not in use; while Chinese buildings can save energy by increasing lighting system efficiency, and improving envelope insulation and HVAC equipment efficiency.

The research outputs from the project can help better understand energy performance of buildings, improve building operations to reduce energy waste and increase efficiency, identify retrofit opportunities for existing buildings, and provide guideline to improve the design of new buildings. The standardized energy monitoring and analysis platform as well as the collected real building data can also be used for other CERC projects that need building energy measurements, and be further linked to building energy benchmarking and rating/labeling systems.

Table of Contents

Introduction	1
The U.S.-China Clean Energy Research Center	1
Research Background.....	2
Research Team and Collaboration	2
Research Objectives, Technical Approach, and Technical Tasks	3
Research Objectives.....	3
Technical Approach.....	4
Technical Tasks.....	4
Research Findings	5
Building Energy Monitoring and Analysis	6
Building Energy Monitoring Systems	8
Introduction	8
Description of monitoring systems	9
A Standard Building Energy Data Model.....	11
Necessity of a data model.....	11
Basic functions	12
Standard model.....	13
Building Energy Data Comparison	14
Introduction of case study buildings	14
Energy data comparison	16
Annual data analysis	16
Monthly data analysis	20
Weekly data analysis.....	24
Daily data analysis.....	25
Summary	28
Discussion	29
Data collection	29
Data sharing	29
Data retrieval	30

Naming of data points.....	30
Missing data	30
Data quality	31
Data correction	31
Data analysis	31
Conclusions	31
References	32
Acknowledgement	34
Appendix A – List of Publications	35
Appendix B – List of Workshops and Major Activities	36
Appendix C – Sourcebook of Case Study Buildings: Description	38
Appendix D – Sourcebook of Case Study Buildings: Energy Analysis	39
Appendix E – Methods and Challenges in Energy Benchmarking between the U.S. and China.....	40

Introduction

U.S. and China are the world's top two economies. Together they consumed one-third of the world's primary energy. It is an unprecedented opportunity and challenge for governments, researchers and industries in both countries to join together to address energy issues and global climate change. Such joint collaboration has huge potential in creating new jobs in energy technologies and services.

The U.S.-China Clean Energy Research Center

In November 2009, President Barack Obama and President HU Jintao announced the establishment of the \$150 million U.S.-China Clean Energy Research Center (CERC, <http://www.us-china-cerc.org/>, <http://www.cerc.org.cn/>). The Protocol formally establishing the Center was signed at ceremonies in Beijing by U.S. Energy Secretary Steven Chu, Chinese Minister of Science and Technology Wan Gang, and Chinese National Energy Agency Administrator ZHANG Guobao.

The CERC builds upon over 30 years of U.S. and China science and technology collaboration. Under the Science and Technology Cooperation Agreement of 1979 and its 1991 amendment, our two countries have cooperated in a diverse range of fields, including basic research in physics and chemistry, earth and atmospheric sciences, a variety of energy-related areas, environmental management and more.

The CERC facilitates joint research and development on clean energy technology by teams of scientists and engineers from the United States and China. It is a flagship initiative funded in equal parts by the United States and China, with broad participation from universities, research institutions and industry. U.S. funds will be used exclusively to support work conducted by U.S. institutions and individuals only, and Chinese funds will support work conducted by Chinese institutions and researchers.

CERC has three research themes: (1) CERC Building Energy Efficiency (CERC-BEE) focusing on research and development of building technologies, tools, and policy to improve design and operation of buildings to reduce energy use in buildings, (2) CERC Clean Vehicles focusing on research and development of new technologies for electric vehicles and alternative fuels to reduce air pollution and carbon emissions from the transportation sector, and (3) CERC Advanced Coal Technology focusing on research and development of technologies to improve efficiency and reduce air emissions of coal power plants and new technologies for carbon capture and storage.

The CERC-BEE Consortium conducts R&D on building energy efficiency technologies and practices in the United States and China. CERC-BEE's vision is to, "To build a foundation of knowledge, technologies, tools, human capabilities, and relationships that position the United States and China for a future with very low energy buildings resulting in very low CO2 emissions."

BEE develops innovative technologies and strategies for use in new and existing buildings to improve efficiency, save energy, reduce greenhouse gas emissions, increase indoor comfort, and reduce stress on the electric grid. As new construction proceeds around the globe, collaborative BEE research efforts are helping to lock in tremendous potential energy savings for the long term

via a more efficient and low carbon built infrastructure. Figure 1 shows the five research areas and projects for the first two years under the CERC-BEE.

Figure 1 CERC-BEE Research Areas and Projects

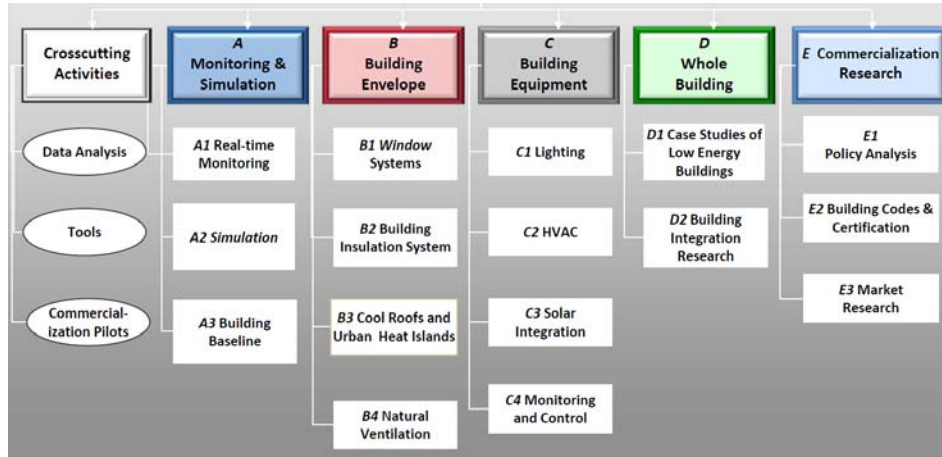

Research Background

Buildings in the US and China consumed about 40% and 25% of the primary energy in both countries in 2010 respectively. Worldwide, the building sector is the largest contributor to the greenhouse gas emission. Better understanding and improving the energy performance of buildings is a critical step towards sustainable development and mitigation of global climate change.

Building energy consumption data collection, monitoring, and analysis are an important basis for building energy research. Buildings in the US and China demonstrate very diverse energy performance which, as a first step, can be compared based on the statistical data. Real time measured energy use data with clear definition, more granularity, better accuracy, and smaller time interval is crucial to better understanding and comparing energy performance of buildings.

Real-time energy monitoring is a solid and proven way to collect and analyze building energy use data. Unfortunately the industry lacks such a standard platform – data definition is confusing, data collection is incomplete, and data cannot be converted or exchanged. This poses a big obstacle to understanding and comparing energy performance of buildings.

Good energy data is the cornerstone to understanding building energy performance and supporting research, design, operation, and policy making for low energy buildings. This project will help develop and install a standardized energy monitoring platform, including standardization of energy data description, hardware and software, to collect and analyze energy use data for a few selected office (or mixed used office) buildings in both countries. The real-time monitoring platform can also be used to troubleshoot operation and control system problems and equipment faults, and be further linked to building energy benchmarking and rating/labeling systems.

Research Team and Collaboration

The joint research team (Table 1) includes the LBNL team, the ORNL team, the U.S. industry partners, the Tsinghua team and the China industry partners. Tianzhen Hong of LBNL led the U.S.

side research and Jianjun Xia of Tsinghua University led the China side research. Richard Karney and Yi Jiang served as the senior technical advisors for the project.

The research team had bi-weekly conference calls to discuss project progress and resolve issues. The team organized a series of workshops (Appendix B) to exchange research findings, seek inputs and comments from researchers, practitioners, industry partners, HVAC manufacturers, government agencies, and other stakeholders. The joint research work also made significant contribution to the IEA Annex 53. Exchanged students from Tsinghua University stayed at LBNL for a few months to work on joint technical tasks.

Table 1 – The Joint Research Team

	The U.S. Side	The China Side
Research Team	The LBNL Team and the ORNL Team	The Tsinghua Team
Principal Investigators	Tianzhen Hong, LBNL	Jianjun Xia, Tsinghua University
Research Team Members	LBNL - Wei Feng, Alison Lu; ORNL - Piljae Im, Mahabir Bhandari	Le Yang, Qi Shen
Industry Partners	C3 Energy	Persagy
Senior Technical Advisors	Richard Karney, USDOE	Yi Jiang, Tsinghua University

Research Objectives, Technical Approach, and Technical Tasks

Research Objectives

This project (Project A1 in Figure 1) aims to develop a standard methodology for building energy data definition, collection, presentation, and analysis; apply the developed methods to a standardized energy monitoring platform, including hardware and software, to collect and analyze building energy use data; and compile offline statistical data and online real-time data in both countries for fully understanding the current status of building energy use. This helps decode the driving forces behind the discrepancy of building energy use between the two countries; identify gaps and deficiencies of current building energy monitoring, data collection, and analysis; and create knowledge and tools to collect and analyze good building energy data to provide valuable and actionable information for key stakeholders.

The research outputs from the project can help better understand energy performance of buildings, improve building operations to reduce energy waste and increase efficiency, identify retrofit opportunities for existing buildings, and provide guideline to improve the design of new buildings. The standardized energy monitoring and analysis platform as well as the collected real building

data can also be used for other CERC projects that need building energy measurements, and be further linked to building energy benchmarking and rating/labeling systems.

Technical Approach

Building energy consumption data collection, monitoring, and analysis are an important basis for building energy research. Buildings in the U.S. and China demonstrate very diverse energy performance which, as a first step, can be compared based on the statistical data. Real-time measured energy use data with clear definition, more granularity, better accuracy, and smaller time interval is crucial to better understanding and comparing energy performance of buildings. Unfortunately the industry lacks such a standard platform – data definition is confusing, data collection is incomplete, and data cannot be converted or exchanged across the existing platforms. This poses a big obstacle to understanding and comparing energy performance of buildings. The methodology we proposed is based on the ISO standard 12655, Energy performance of buildings - Presentation of real energy use of buildings, to ensure all selected Chinese and US buildings' data are collected and stored in a consistent structure. This will facilitate data storage, analysis and comparison. The value of ISO standard could be demonstrated through this project. Some of the data analysis methods come from the LBNL Energy Information System Handbook, but the focus is also on new data analytics to enable the detailed comparison of energy use of the selected buildings in China and the U.S.

Multiple existing energy monitoring platforms were reviewed and one was selected for the project. But as an important part of the project, we identified gaps and provided a list of enhancements to be implemented in the selected platform, including standardization of building energy data description, approaches to monitoring or collecting of three types of building data at 15-minute time interval: (1) energy use, (2) equipment operation, and (3) environmental conditions, requirements of sensors and meters, and computer hardware and software, to collect and analyze energy use data for a few selected office (or mixed used office) buildings in both countries. The data analysis will focus on two levels: in-depth analysis of energy performance of an individual building to obtain detailed end uses at various time scales and energy usage patterns; and comparative analysis of energy performance across multiple buildings and two countries to identify and understand key drivers of discrepancies of energy use of buildings. Potential energy savings measures for the selected buildings will be analyzed and recommended to corresponding building management teams or owners.

The proposed project teams will collaborate with the U.S., Chinese, and international organization involved in building performance tracking, benchmarking, rating and labeling, including the DOE building performance database and asset rating programs, ASHRAE energy labeling, the Data Access and Transparency Alliance (a U.S. national partnership of real estate and green building organizations), the IEA (International Energy Agency) Annex 58 Reliable Building Energy Performance Characterization Based on Full Scale Dynamic Measurements, and IEA Annex 53 Total Energy Use in Buildings: Analysis and Evaluation Methods.

Technical Tasks

The project consists of five technical tasks:

Task 1 - Review existing real time energy monitoring platforms.

Task 2 - Develop a standard platform for data collection based on the data models of the proposed ISO Standard 12655 - Presentation of real energy use of buildings.

Task 3 – Select a few office (including mixed used office) buildings in both countries with existing or new energy monitoring systems to collect energy use data.

Task 4 - Develop methods for data filtering and data mining (analysis and visualization) to help decision making of different levels of users – building owners, operators, facility managers, occupants, and investors.

Task 5 - Use the standard platform and the collected data to compare energy use of buildings in both countries to identify and better understand the key drivers of the differences.

Research Findings

Key research findings were summarized as follows. Detailed description of research work, technical approaches, and results are provided in following sections, and also published in 5 journal articles and 3 conference papers (Appendix A).

- Identified the need for a standard data model and platform to collect, process, analyze, and exchange building performance data due to different definitions of energy use and boundary, difficulty in exchanging data, and lack of current standards.
- Compared energy monitoring systems to identify gaps, including iSagy, Pulse Energy, SkySpark, sMap, EPP, ION, and Metasys.
- Developed a standard data model to represent energy use in buildings (ISO standard 12655 and a Chinese national standard)
- Determined that buildings in the United States and China are very different in design, operation, maintenance, occupant behavior: U.S. buildings have more stringent comfort standards regarding temperature, ventilation, lighting, and hot-water use and therefore higher internal loads and operating hours, and China buildings having higher lighting energy use, seasonal HVAC operation, more operators, more use of natural ventilation, less outdoor ventilation air, and wider range of comfort temperature.
- Completed data collection for six office buildings, one in UC Merced campus, one in Sacramento, one in Berkeley, one in George Tech campus, and two in Beijing.
- Compiled a source book of 10 selected buildings in the United States and China with detailed descriptions of the buildings, data points, and monitoring systems, and containing energy analysis of each building and an energy benchmarking among all buildings.
- Recognized limited availability of quality data, particularly with long periods of time-interval data, and general lack of value for good data and large datasets.
- Compiled a building energy database, with detailed energy end use at 1-hour or 15-minute time interval, of six office buildings – four in the U.S. and two in China. The database is available to the public and is a valuable resource for building research.

- Developed methods and used them in data analysis of building performance for the five buildings with adequate data, including energy benchmarking, profiling (daily, weekly, monthly), and diagnostics.
- Recommended energy efficiency measures for building retrofit in both countries. U.S. buildings show more potential savings by reducing operation time, reducing plug-loads, expanding comfort temperature range, and turning off lights or equipment when not in use; while Chinese buildings can save energy by increasing lighting system efficiency, and improving envelope insulation and HVAC equipment efficiency.

Building Energy Monitoring and Analysis

Worldwide, the building sector is the largest emitter of carbon dioxide (CO₂) and the main contributor to climate change (Architecture 2030, 2012). Buildings account for 72% of U.S. electricity use and 36% of natural gas use, and U.S. buildings currently contribute 9% of the world's CO₂ emissions (U.S. Department of Energy [USDOE], 2008). In 2007, China's building sector consumed 31% of China's total primary energy (International Energy Agency [IEA], 2007). China is also the second largest building energy user in the world, ranking first in residential energy consumption and third in commercial energy consumption (Eom, Clark, & Kim, 2012). In both developed and developing countries, buildings are responsible for more than 40% of global energy use and one-third of global greenhouse gas emissions (United Nations Environment Programme [UNEP], 2009). In 2011, buildings in the U.S. and China consumed 41% and 28% of total primary energy in both countries, respectively. Furthermore, China's percentage is on the rise.

Better understanding of and improvements to building energy performance and operation are critical steps toward sustainable development and mitigation of global climate change. In the building sector, two distinct scenarios apply: Buildings in China have lower design efficiency levels (Hong, 2009) but also lower needs in terms of energy use; buildings in the United States have higher design efficiency levels but also higher needs for energy use. As a result, U.S. buildings use much more energy than those in China. This is mainly driven by essential differences between building operation and occupant behavior in both countries: Chinese buildings typically operate in a part-time, part-space mode – only occupied spaces during occupied time are conditioned, while U.S. buildings typically operate in a full-time, full-space mode – the whole building is conditioned most of the time including unoccupied hours with thermostat setback (Jiang, 2012). Therefore while buildings in the world's two largest economies have large energy savings potential, different energy savings measures will be needed.

Good building energy data is the foundation for research and building energy efficiency policy making. Energy monitoring, data collection, and analysis play crucial roles to support the design and operation of low energy buildings. Several studies, including a National Institute of Standards and Technology (NIST) report, show that energy feedback devices can provide real energy savings by motivating building occupants to modify behavior, and while the level of savings varies, typical energy reductions on the order of 10% can be expected (Healey, 2010). Moreover, a commissioning study shows that problems of building energy performance are pervasive and well known (Mills et al., 2005).

Keeping in mind the importance of monitoring and building energy performance management and to further the understanding of building operations, an Energy Information Handbook, published by Lawrence Berkeley National Laboratory (LBNL), is part of a DOE sponsored project to educate commercial building owners, facility managers, and operators (Granderson, Piette, Rosenblum, & Hu, 2011). The importance of this field is also emphasized by the fact that International Standards Organization (ISO) is developing a Standard 12655, Energy Performance of Buildings — Presentation of Real Energy Use of Buildings (ISO 2012), to standardize the data model used to represent measurement and performance data across all buildings and participating nations. DOE is also working on a building performance database to provide engineering and financial practitioners with a decision-support platform that enables them to evaluate energy efficiency products and services in commercial and residential buildings. The IEA's Energy Conservation in Buildings and Community Systems (ECBCS) Annex 53, Total Energy Use in Buildings: Analysis and Evaluation Methods, also aims to develop new methods and tools to better understand and predict energy use of buildings (IEA, 2009-2012).

Several cities in both countries are actively installing online measurement and monitoring platforms, which mostly measure electricity consumption, cooling loads, indoor air temperature, etc. Electricity consumption measurements include not only total use, but also each major end use, sub-circuit branch use, and large power equipment use. However, most of these building energy monitoring platforms are relatively isolated and lack a common data structure. This makes communication and exchange of building energy performance data difficult. One of the challenges in comparing the performance of a set of buildings that have different data acquisition systems, data output formats, and energy analysis platforms is the lack of a common platform for data analysis. To make the communication and exchange of building energy consumption information seamless across all monitoring platforms and building automation systems (BAS), a standard and uniform building energy use description and a definition of minimum measured data requirements are urgently needed. Furthermore, most monitoring systems are separated from existing BAS, which leads to incomplete data collection and places extra burden on building owners and operators to run and manage both systems. Data analysis capability is also limited in providing actionable information for key stakeholders and decision makers to achieve energy savings.

To better understand building energy performance and improve building operations to reduce energy waste and increase efficiency, and more importantly to investigate the discrepancy in building energy use between the U.S. and China, a study of buildings in both countries with different climatic conditions and occupant cultural differences can play an important role.

A dozen buildings with online measurement and monitoring platforms were selected across the several climatic conditions in both countries. To gain a detailed understanding of building performance, measurements included three types of data at one-hour or 15-minute intervals: (1) building energy use, including building totals and a breakdown into major end uses for various fuel types; (2) operating conditions of HVAC systems and equipment; and (3) indoor and outdoor environmental conditions. The collected data was analyzed for three main purposes: (1) energy profiling — annual and monthly end uses, weekly and daily use patterns; (2) energy benchmarking — comparison of annual and monthly energy end uses among selected buildings to identify and

understand driving factors of high performance buildings and demonstrate good design and operation practices; and (3) energy diagnostics — analyzing the performance of HVAC systems and the central plant to identify potential energy and operating issues and recommend retrofit measures.

We first reviewed and compared several popular existing building energy monitoring systems in the U.S. and China. System structure, function, and performance are compared for each monitoring system, and the common field and basic functions of these monitoring systems are discussed. Next a standard energy data model for building energy monitoring is presented. Then a detailed building energy data comparison was done for a few selected office buildings in both countries. Finally, issues of data collection, quality, sharing, and analysis methods are discussed.

Building Energy Monitoring Systems

Introduction

Granderson et al. (2011) reviewed and summarized the characteristics of more than 20 building energy information systems (EIS), as well as their differences with building management systems (BMS) and energy management and control systems (EMCS). The study covered key EIS characteristics: data collection, transmission, storage and security, displays and visualization, energy analysis, advanced analysis, financial analysis, demand response, remote control and management, and other general management issues.

In general, building information tracking can be categorized as system tracking and energy tracking, as shown in Figure 2. System tracking focuses on building systems (such as lighting and HVAC) performance, including basic building automation control, fault detection and diagnostics (FDD), and continuous system optimization. Energy tracking focuses on building energy consumption. Based on customer needs and metering strategies, energy tracking can further be divided into utility tracking and benchmarking, meter visualization, and EIS. Utility tracking and benchmarking takes a whole building's portfolio and looks at its energy performance. Meter visualization is used to analyze more detailed building sub-metering information and calculate building end-use energy.

Some systems offer comprehensive solutions and a generic application programming interface (API) for both energy and system tracking. These systems require secondary programming to meet each user's needs. This offers great flexibility to energy and system tracking, allowing users to build a system topology and embed different algorithms for data processing and analysis.



Figure 2 - Building performance tracking systems (courtesy Jessica Granderson at LBNL).

Description of monitoring systems

The monitoring systems used for the selected buildings are summarized in Table 2. These systems include both commercially available and in-house developed platforms. Figure 3 shows the graphical user interface (GUI) of one monitoring system.

Table 2 - Energy monitoring systems

System	Developer	Database	Availability	API	GUI	Flexibility
iSagy	Persagy, China	SQL server	Commercial	n/a	Web	Medium
Pulse Energy	Pulse Energy, U.S.		Commercial	n/a	Web	Limited
EPP	LBNL, U.S.	SQL server	Public	n/a	Web	Good
SkySpark	SkyFoundry, U.S.	"Folio"	Commercial	Yes	Web/standalone	Good
ION	Schneider Electric, France		Commercial	n/a	Web/standalone	Limited
sMAP	UC-Berkeley, U.S.		Public	n/a	Web	Good
Metasys	Johnson Control, U.S.		Commercial	n/a	Web	Limited

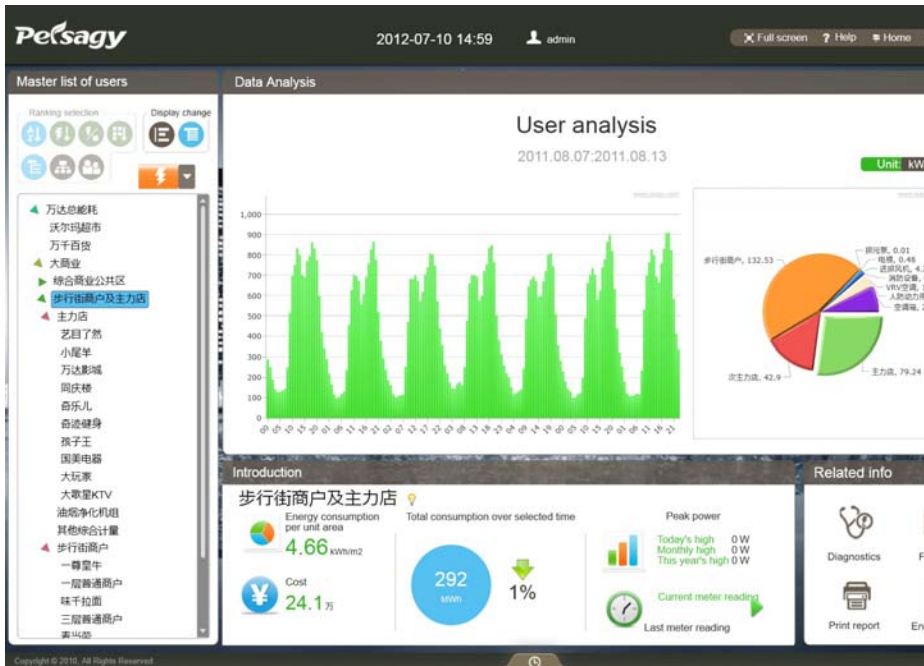

(a) Tenant comparison, showing end-use energy and daily use tracking.

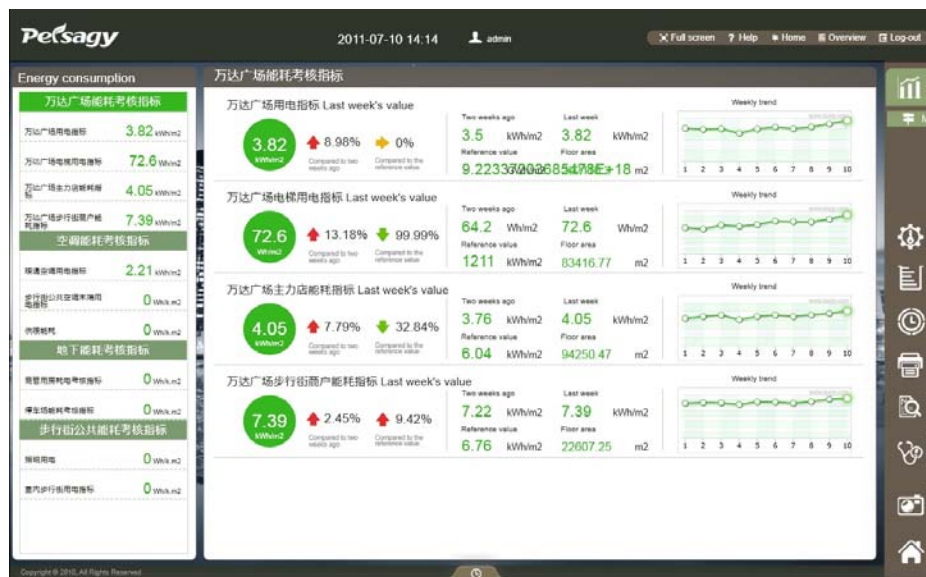

(b) Energy use intensities, showing trend of energy use.

Figure 3 - Screenshots from Persagy's iSagy platform.

Key features of these systems are shown in Table 3. All the systems share some characteristics, such as a centralized database, data acquisition module, and a data visualization GUI. In summary, most systems can provide good support on technical features, data analysis, and fault detection, but each has different capacities in terms of data analysis and fault detection. Some in-house-developed systems have relatively simple GUI and user-customized functions, while some commercialized platforms often offer better GUI and more comprehensive data processing capability. Generic

monitoring software (such as SkySpark) has great flexibility to implement all the necessary data analysis functions. However, secondary development and programming expertise is often required to achieve such functions.

Commercial systems are good for general energy sub-metering and monitoring, while in-house systems can be specifically targeted to unique user needs and are mostly suitable for research purposes. Generic tools such as SkySpark are good for either commercial applications or research development. However, since secondary development is involved, the system must be customized before delivering to end users.

Table 3 - Feature summary of energy monitoring systems.

System	Technical features										Analysis features										Fault detection							
	Including hardware for acquisition	Automatic data acquisition	Manual data entry	Automatic data processing	Platform independent	CSV-Import	CSV-Export	Interfaces to BMS	Automatic chart generation	Interactive charts	Stand-alone software	Web frontend	Interpolation if arbitrary measure intervals	Virtual sensors	Definition of any reference values	Comfort analysis	Statistical analysis	Real-time diagnosis	Climate correction	Report system	Tools for benchmarking	Prediction of energy savings	Prediction of cost savings	Analyze building subsystems	Data integrity validation	Check by value ranges	Email notification	
iSagy																												
Pulse Energy																												
EPP																												
SkySpark																												
sMAP																												
ION																												

A Standard Building Energy Data Model

Necessity of a data model

As a platform of building energy conservation management and auxiliary diagnosis, the building energy monitoring system is designed on a national or even global building energy database. The monitoring system is multi-user and object oriented, which differs from traditional building information and management systems like BAS, EMCS, and BMS. Analyzing the differences by comparing the data among a large portfolio of buildings is the main advantage of such a standard monitoring system.

Common building energy diagnosis methods focus on some details of subsystem models, analyzing operational performance using various types of data, such as air-flow rate, water-valve opening, and supply and return air temperature and humidity. However, in the monitoring system, these common diagnosis methods are not well implemented. Common methods of energy conservation analysis rely on the in-depth study of a detailed building load model or detailed mechanical and control models. The methods, based on monitoring systems, employ an empirical building model derived from detailed statistical analysis. Furthermore, some operational problems can be found

more easily by making comparisons between buildings rather than doing a longitudinal analysis of a single building.

As cross-sectional comparison is the basic analysis method in monitoring systems, building energy data models should be uniform to assure that energy data and system structure are comparable. Building data and information, especially time-series energy use, can then be compared between different buildings, and even different monitoring systems. The monitoring system would produce more knowledge on building energy performance with a database of a large number of buildings.

Most existing monitoring systems focus on energy data analysis in a single building and do not fully consider the use of a building data model. For example, Brown, Wright, Shukla, and Stuart (2009) diagnosed the operational schedule problem of lighting using hourly electricity data, but the monitoring structure and energy model were not mentioned. Dong, Lee, and Sapar (2005) tried to find the linear relationship between energy consumption and climate parameters. With this linear building energy model, the monthly building energy data can be made uniform and comparable, but only total accumulated data was considered. For benchmarking studies, researchers (Mlecnik, Bossaer, & Coolen, 2003; Sartor, Piette, & Tschudi, 2000; Kinney & Piette, 2002) compared monthly or annual total energy use, but ignored detailed operational information and correlation in the hourly time-series data, and therefore lacked a comprehensive data comparison. Thus, it is necessary to discuss and unify the functions of the system, and define the types of data for collection. A standard building energy data model should be developed to make monitoring systems comparable and valuable.

Basic functions

Data storage, automatic correction, data analysis, visualization, and reporting are basic functions of a monitoring system (Akihiro & Mitsuhiro, 2012; Noreacuten, 2010; Piette, Kinney, & Haves, 2001). In particular, visualization and reporting are extensively discussed in subtask B2 of IEA Annex 53. However, these functions are used for final analysis and presentation purposes, while the fundamental background function, data processing, still needs more research.

Many studies have looked at operational fault diagnosis and benchmarking, even if they are independent topics. The energy monitoring system is just a bridge connecting them. Energy monitoring and comparison is the core of the system; meanwhile this system also offers auxiliary information and analysis for benchmarking and detailed diagnosis. Thus, there are three levels of monitoring system function on data processing: (1) audit and benchmarking, (2) monitoring and management, and (3) energy conservation and operational performance diagnostics.

The first level is usually available in most existing monitoring systems or benchmarking databases. The whole building's annual or monthly data is compared or ordered according to its climate zone and building type. Statistical methods can be used to analyze the profile of energy consumption and its correlation with climate parameters. For short- and medium-term management, the second level mainly includes monthly or weekly energy auditing, analysis of daily energy consumption by various end uses, characteristics comparison, and the analysis of a 24-hour curve of various end uses. Comparison approaches can use common references, be between buildings, or use historical records of the same building. Comparison at various intervals is a brief but efficient approach to

managing the building’s operational performance. The third level is for preliminary diagnosis in a microcosmic view. Hourly time-series analysis, correlation analysis, and efficiency calculation provide more assistance to on-site investigation and diagnosis.

Standard model

To realize all three basic functions, the collected information and energy data should cover various types of end uses in a short time interval. The proposed model structure generally follows the building energy use model in the ISO Standard 12655 (ISO, 2012). Considering the wide use of electricity in the buildings studied and the technical difficulty of gas and water sub-metering, only electricity is submetered, which distinguishes our structure slightly from the ISO model approach. Thus the building energy data model is designed in two parts: (1) basic building information, total energy data, and some operational parameters listed in Table 4. In this part, energy use is categorized by energy type and the total energy use. (2) An electricity sub-metering tree model, as shown in Figure 4. In this sub-metering model, total building energy use is segregated by HVAC, lighting and appliance, public service, and special uses. These four major categories have detailed sub-items. Compared with the ISO model, other end usage is renamed as public service, and the service hot water item is moved to the public service category, as only the pump’s electricity use is considered. Furthermore, the sub-items are designed more meticulously in the HVAC category.

Table 4 - Building information and operational data

Type	Item	Comment	Interval
Building information	Year of construction	Retrofit time	-
	Location	City and climate zone	-
	Size	Floor area, conditioned area without parking and storage	-
	Shape coefficient	External surface area divided by the total volume of a building	-
	HVAC system types	Centralized or decentralized, including types of cooling & heating sources and terminal devices	-
	Cooling & heating degree-days		-
Energy consumption and thermal loads	Electricity	Sub-metering tree model	Hourly
	Gas	Total used	Daily
	Oil	Total used	Daily
	Renewable energy	Solar power, wind power, etc.	Hourly
	Water	Service hot water, recycle water	Daily
	Cooling and heating loads	Chilled & hot water, supply & return water temperature	Hourly
Conditional parameters	Outdoor air temperature and humidity	Dry-bulb and wet-bulb temperature	Hourly
	Solar radiation intensity	Horizontal	Hourly
	Indoor temperature & humidity	Dry-bulb and wet-bulb temperature	Hourly
	Number of people		Daily
	Outdoor air-flow rate	At air-handling unit (AHU)	Hourly

As seen in Table 4, the data interval varies with energy end-use type, resulting in several energy databases at various time intervals. The monitoring systems record data at an interval of five minutes or even shorter, but the data downloaded for analysis are at a longer interval, for example, 15 minutes or an hour. By aggregation, monthly and annual databases are available from the short-interval database.

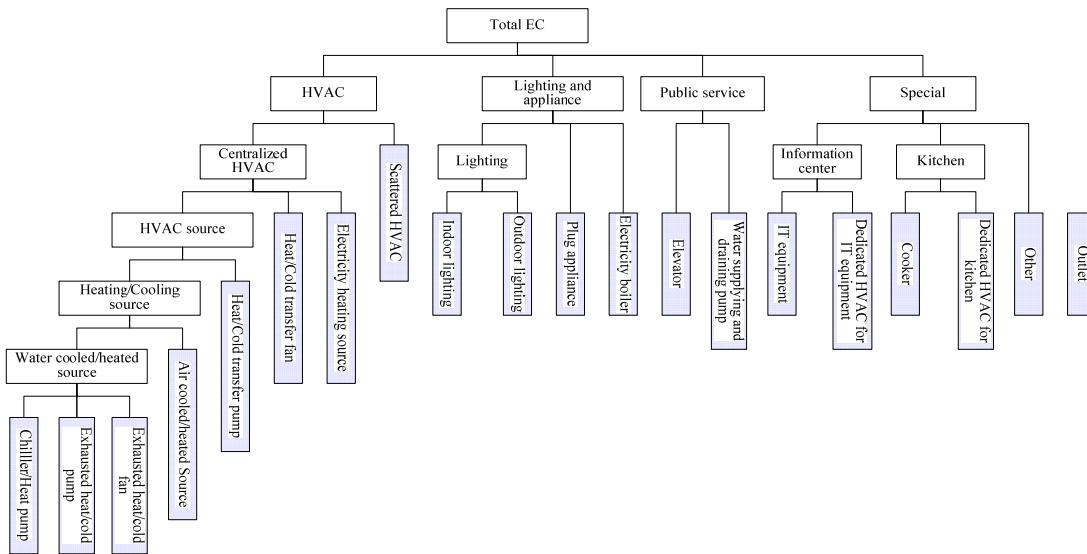

Figure 4 - Electricity sub-metering model

The electricity sub-metering model follows a tree structure, from total energy use down to each terminal device. HVAC, lighting and appliances, public services, and special are defined as the first subclass. The detailed sub-items' classification for each main component are defined step by step. The model contains 31 nodes. Except for the outlet node, 19 basic nodes indicate a certain kind of equipment, and 12 are composite nodes.

The HVAC component is separated into four levels: centralized or scattered AC systems, centralized plant and terminal AC equipment, source and user (primary and secondary) pumps, and water-cooled and air-cooled sources. Lighting and appliance is further separated into indoor and outdoor lighting, plug-in devices, and electrical boilers. Public service includes elevators and plumbing systems. The special component includes information and data centers, kitchens, and others.

The model has a clear structure and logical relation between each sub-item. It can be used in most types of large-scale commercial buildings, including office towers, hotels, and shopping malls.

Building Energy Data Comparison





Introduction of case study buildings

To deeply understand the discrepancies of building energy use between the U. S. and China, identify the drivers to different performances, and then provide guidance and insights for the retrofit of existing buildings as well as the design and operation of future low energy buildings, a few typical buildings from both countries were selected for analysis and comparison. The buildings met most of the major selection criteria and include the information listed below as much as possible:

1. Medium to large-size office buildings were preferred, as they are the most common types of commercial buildings (referred to as “public buildings” in China). The end uses of such buildings can be more easily clarified as there are not so many special devices or complicated systems as in other building types, such as hospitals.
2. Physical characteristics: total floor area, number of stories, vintage, location, operating hours, number of occupants, description of building energy service systems.
3. Detailed energy sub-metering for major end uses, including lighting, plug-loads, data center if any, elevators, service water heating, and HVAC (chiller, boiler, cooling tower, fan, pump, any direct expansion [DX] unit and radiators).
4. At least one full year’s valid measured energy use data at one-hour or shorter time intervals.
5. Overview of the monitoring system showing the hierarchy of sub-metering.
6. High-level description of BMS, including key data points.
7. Optional but necessary for HVAC analysis and diagnostics: typical HVAC system and central plant operating conditions. For example, chiller power consumption, cooling loads, chilled water flow rate, inlet and outlet water temperature; AHU supply airflow rate, fan power, supply air temperature, etc.
8. Optional but good to have: indoor conditions, including typical space air temperature and humidity; outdoor conditions, including outdoor air temperature and humidity, wind speed and direction, solar radiation.

A dozen office buildings, five in the U.S. and seven in China, were selected based on the above criteria. Four of the buildings, which have completed data collection and initial analysis, were used for detailed analysis and comparison. Table 5 summarizes key information of the four buildings.

Table 5 - Basic information of the case study buildings

Name	Building A	Building B	Building C	Building D
Location	Beijing, China	Beijing, China	Merced, California, U.S.	Berkeley, California, U.S.
Climate (HDD18°C/ CDD10°C)	Zone 4B, 2,918 / 2,286	Zone 4B, 2,918 / 2,286	Zone 3B, 1,495 / 2,657	Zone 3C, 1,612 / 1,614
Year Built	1989	1987	2005	1960
Floor area (m ²)	54,490	39,211	16,000 (7,000 for the office wing)	8,316
Operation hours	M-F 7 a.m.-6 p.m.	M-F 6 a.m.-6 p.m.	M-F 7 a.m.-6 p.m.	M-F 7 a.m.- 6 p.m.
HVAC	Water-cooled chiller, district heating, VAV + CAV systems	Decentralized AC for cooling, district heating	District cooling, district heating, VAV systems	Local electric cooling and gas-boiler heating Centralized and packaged DX systems
Monitoring Platform	iSagy	iSagy	EPP	Pulse Energy
Data Interval	1 hour	1 hour	15 min	15 min
Photo				

Building A is a large, mixed-use commercial office building with some restaurants, stores, and a bank. It consists of a tall main building with large glass curtain walls and an annex. Building B is a government administrative office building, served by decentralized cooling systems and district heating with radiators, without any other air-side equipment. Building C is a mixed-use building with a library wing (9,000 m²) and an office wing (7,000 m²), and is served by the campus' district cooling and heating systems. Only the office wing is used in this study. This building was newly built with a design energy goal of 38% greater energy efficiency than the 2001 California Title 24 standards (Green Building Research Center, UC Berkeley, 2008). Building D is the oldest among these four buildings, with metal-panel walls without insulation; and leaky, single-pane, clear-glass windows. It is served by various DX HVAC systems.

Energy data comparison

A whole year of energy use data for each building were selected and compared based on annual, monthly, weekly, and daily analysis. Since there is no data for space heating in the selected Chinese buildings, only electricity consumption was compared in this study. The electricity consumption was normalized by using the gross floor area (not the conditioned floor area) of each building to obtain the energy use intensity (EUI) for comparison.

When calculating the EUI for Building C, the total area of 16,000 m² was used for sub-items that involve the whole building, just like the other buildings, while 7,000 m² was used for sub-items that only involve the office wing. As an exception, while the elevator is an electricity end-use shared by both wings, the library wing, with more floating people and a longer operation time, has much higher elevator use rate than the office wing. Therefore to split the elevator electricity use, the office wing is roughly considered to account for only 25% of the total. In addition, a ratio based on cooling tonnage consumed by all campus buildings to cooling tonnage of Building C was used to roughly estimate the percentage of plant equipment (chillers, pumps, and cooling towers) energy consumed by Building C.

Annual data analysis

Figures 5 to 8 show a breakdown of annual total electricity use for the four buildings. Since the sub-metering systems in these buildings differ significantly in terms of detailed subcategories, the end-use structure shown in these figures is not exactly the same as the proposed standard energy data model.

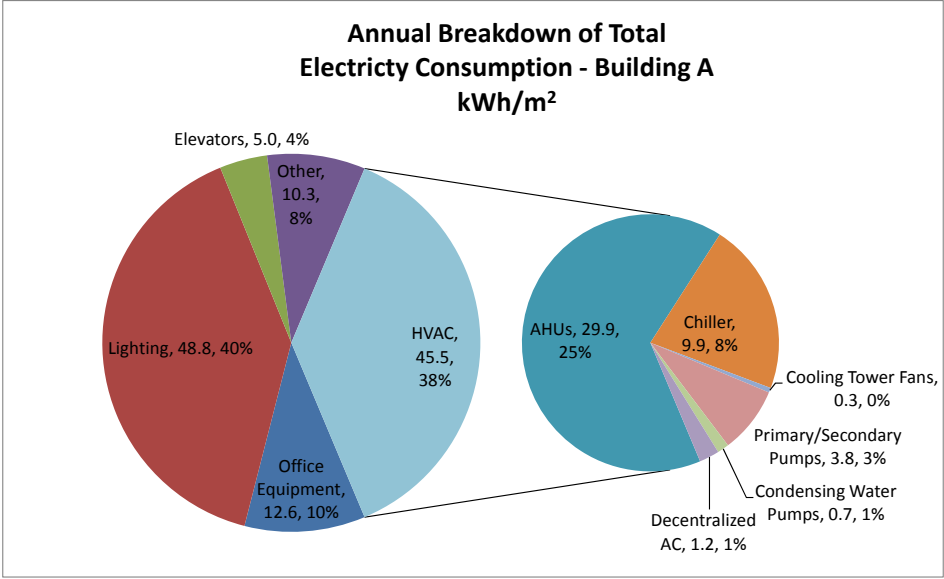

Figure 5 - Building A total annual electricity usage breakdown.

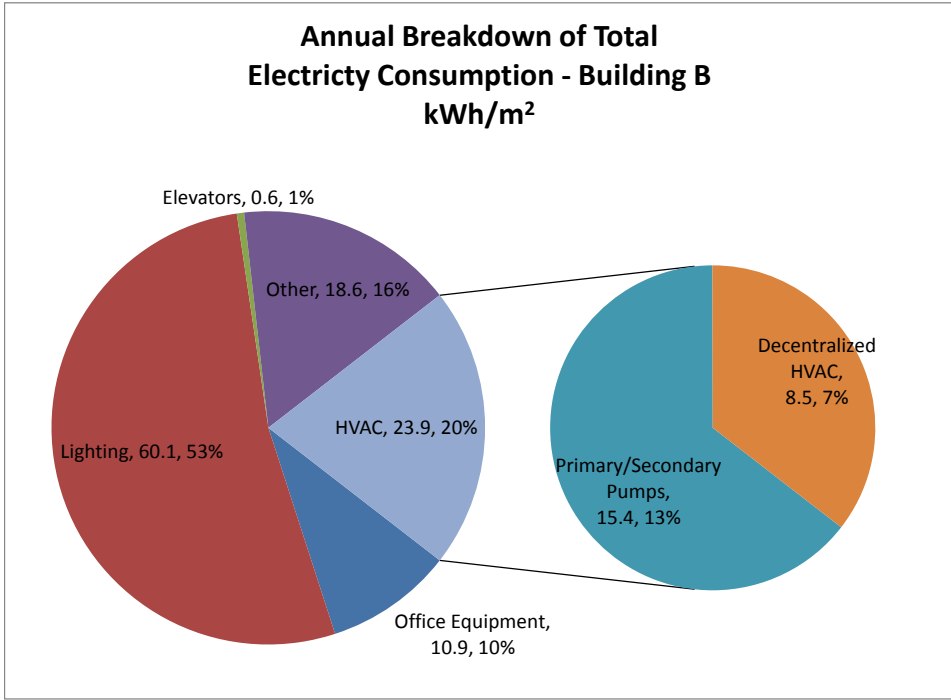

Figure 6 - Building B total annual electricity usage breakdown.

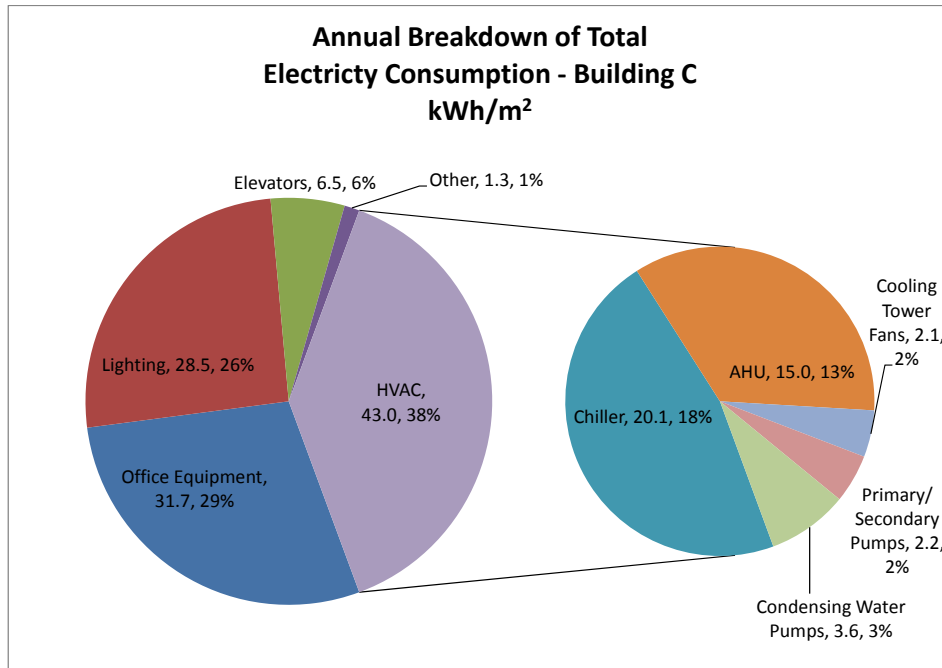

Figure 7 - Building C total annual electricity usage breakdown.

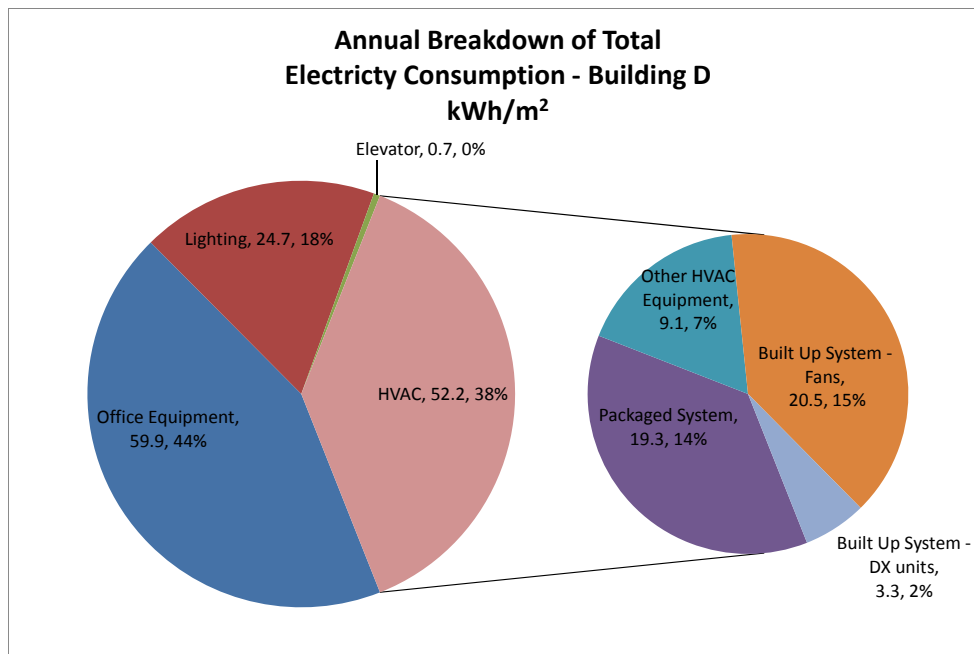

Figure 8 - Building D total annual electricity usage breakdown

As a consequence of the relatively rough sub-metering system of Building D, the breakdown for this building is not as specific as that of the other buildings. The sub-item “Other” shown in the Buildings A, B, and C is included in the “Office Equipment” in Building D. In terms of HVAC, the packaged systems include rooftop units and ductless split units, while the built-up system consists of fans and DX units. The DX units consume a very small amount of electricity mainly because they are usually off when fans can operate alone with cool outside air due to the airside economizer.

Besides, there is a mixed sub-item containing some other HVAC equipment like a small AHU, service hot-water pumps, and a fan that can't be separated.

To compare these buildings and typical office buildings in both countries, the annual total electricity consumption of each building was broken down into four major subcategories, as shown in Figure 9. The data source of the typical Chinese office building is the 2007 Beijing Municipal Government Office Buildings and Large Public Building Energy Consumption Statistical Summary (BECSS, 2007), which is the average of 513 office buildings in Beijing, including 102 Class 1 large administrative office buildings, 379 Class 2 large commercial office buildings, and 32 Class 3 common office buildings. The data source of the typical U.S. office building is the California Commercial End-Use Survey, available from the EnergyIQ website (LBNL, 2012). It is the average of 112 office buildings in California, built after 1940, and with a total floor area of 25,001~150,000 ft² (about 2,323~13,935 m²).

Data for HVAC in these buildings may include energy consumption on equipment related to space heating (primary/secondary pumps, AHUs, etc.), though excluding space heating source energy. The subcategory “other” in the figures can be a mix of things, such as elevators, data centers, kitchen equipment, sewage drainage pipes, etc.

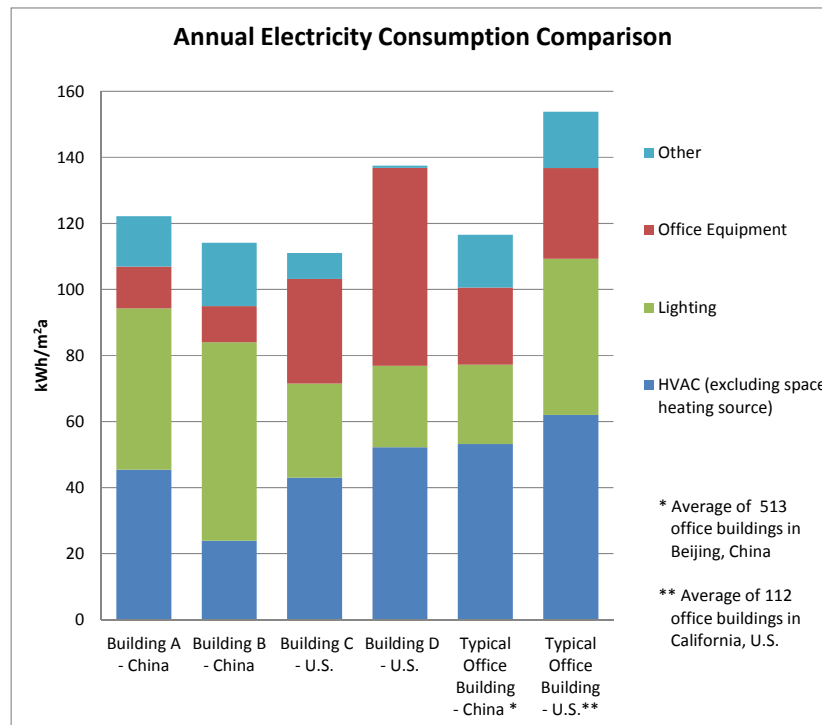

Figure 9 - Annual electricity consumption comparison of case-study buildings against typical office buildings in China and the U.S.

For the total annual electricity consumption, Buildings A and B performed similarly to the typical Chinese office building. However the two U.S. buildings, especially Building C, consumed much less energy than the typical U.S. office building. The more efficient lighting and HVAC systems contributed to the lower energy use of Building C.

In terms of HVAC, Building B, which uses decentralized HVAC for cooling, consumed the least electricity, which indicates that a decentralized HVAC may perform more efficiently than a centralized HVAC. Building D, though located in a warmer zone, consumed more HVAC energy than the Chinese buildings. This may be caused by several factors. First, Building D's indoor space temperature setpoint for cooling is 21~22°C, while Building A's is 24~26°C. Second, Building D's old and poor envelope results in much higher cooling and heating loads. Finally, in general, more outdoor air is provided in the U.S. buildings, and related U.S. ventilation standards are more stringent than those in China, leading to more electricity use to condition outdoor air.

As for lighting, the Chinese buildings consume much more energy than do the U.S. buildings. This may be a combination of design and operation: lighting power, occupant density, operation mode of lights, and different use of natural light. What's more, according to the sub-metered data, Building B's lighting system not only consumes more electricity during the daytime, but also stays high at night, contributing to the greatest lighting energy use among the buildings. On the other hand, Building D's single-pane windows introduce more natural light, and its lighting system has gone through some retrofit. In addition, occupancy sensors in Buildings C and D turn off lights when occupants leave the office for longer than five minutes. More information is needed to decide whether the lighting systems in Buildings A and B need retrofit. However, the typical office building in the U.S. consumes more lighting energy than that in China. This may be caused by large variations of lighting electricity use in the survey buildings. In general, lights in most U.S. office buildings are on during the day and most of the night and without occupancy sensor control, which lead to more energy use than typical Chinese office buildings.

Meanwhile, the two U.S. buildings, especially Building D, consume much more electricity in office equipment than do the two Chinese buildings. Though the office equipment of Building D is mixed with some other equipment, excluding the elevator, it's still much higher than the sum of "Office Equipment" and "Other" of other buildings. Many computers in Building D are left on or in standby mode at night for various reasons, including remote access by staff, data backup, and operating system and security software updates. This building also has more personal fans, heaters, and desktop task lights, which lead to higher electricity use in this sub-item.

Monthly data analysis

After an overview of annual total electricity consumption, it's imperative to go further, into monthly data analysis. The data of these buildings were selected from different time periods. To make comparison easier, the time series on the horizontal axis is set uniform, from January to December, but actual data can cross two calendar years.

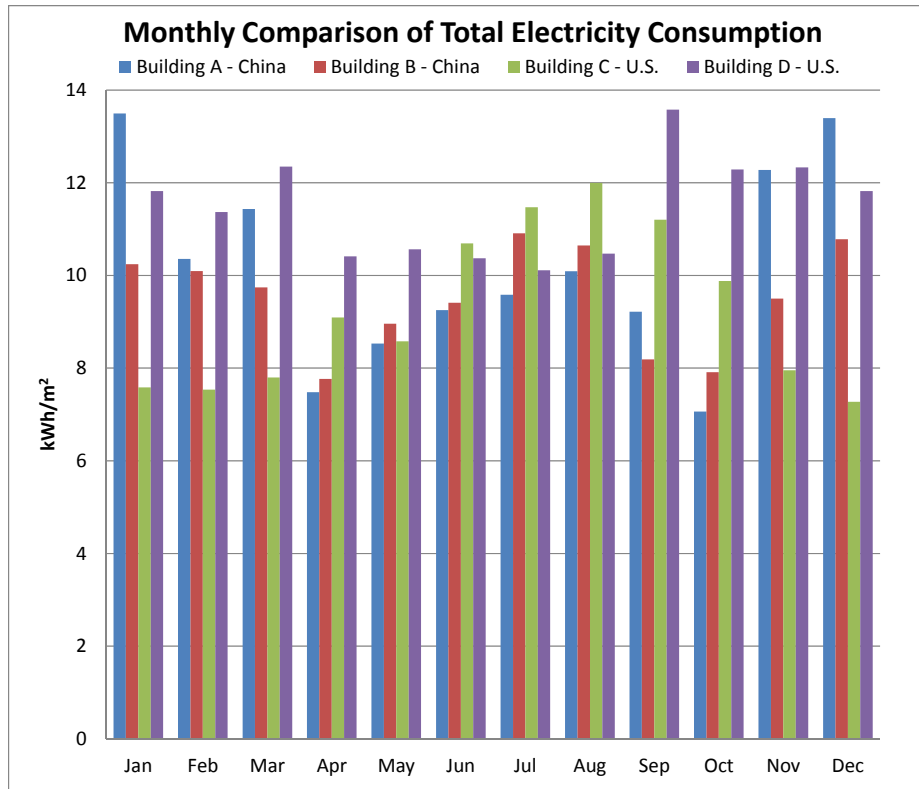

Figure 10 - Monthly comparison of total electricity consumption.

It's clear that the four buildings differ widely in total electricity consumption from month to month. The discrepancy is much larger in winter than in summer. Buildings A and B consume more energy than Building C in winter but less in summer, while electricity use of Building D is always at a relatively high level. To determine the reason for the differences, a monthly breakdown of total electricity use for each building is shown in Figures 11 to 14.

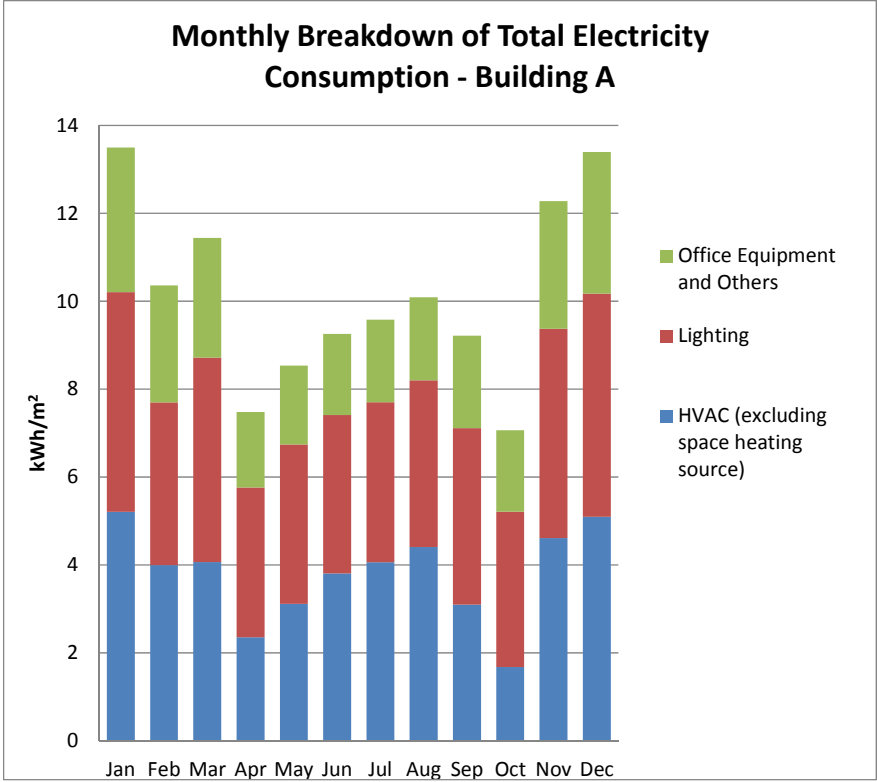

Figure 11 - Building A monthly electricity consumption.

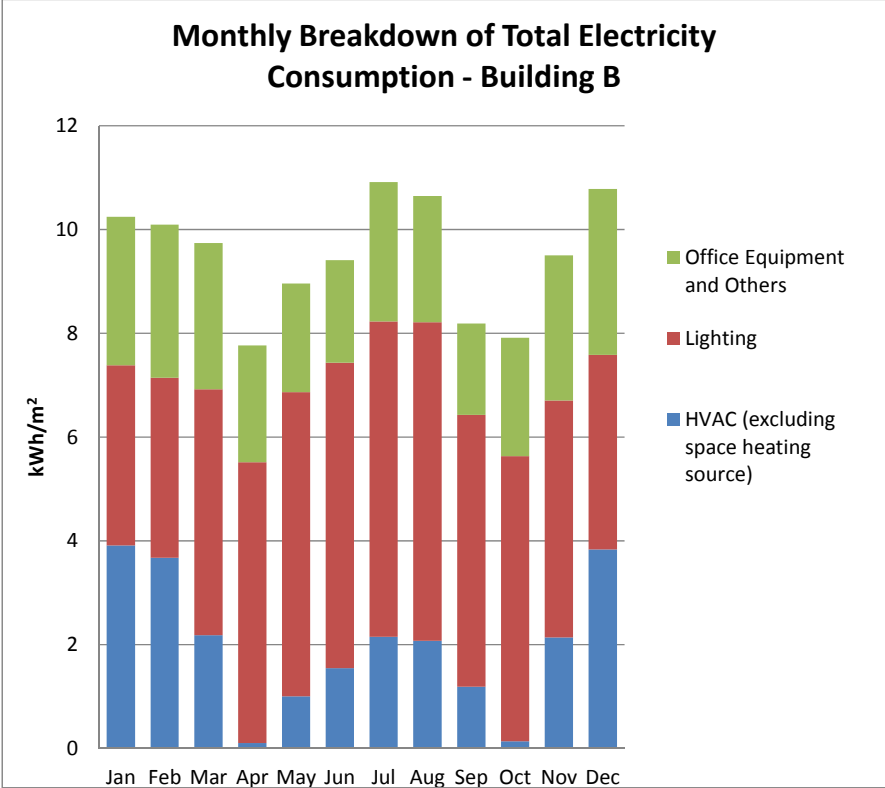

Figure 12 - Building B monthly electricity consumption.

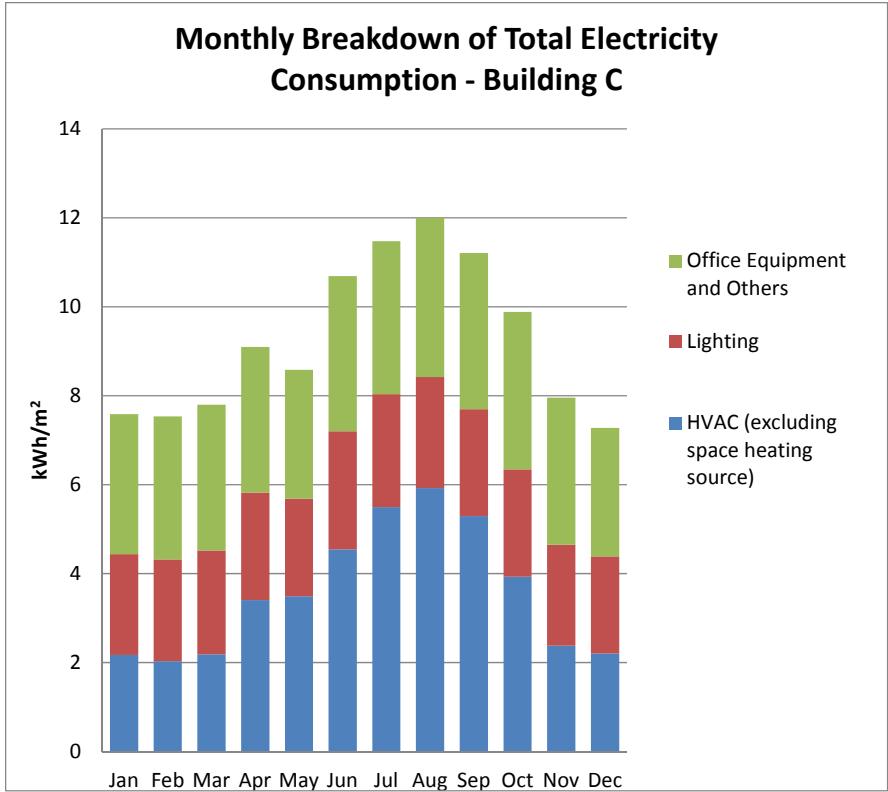

Figure 13 - Building C monthly electricity consumption.

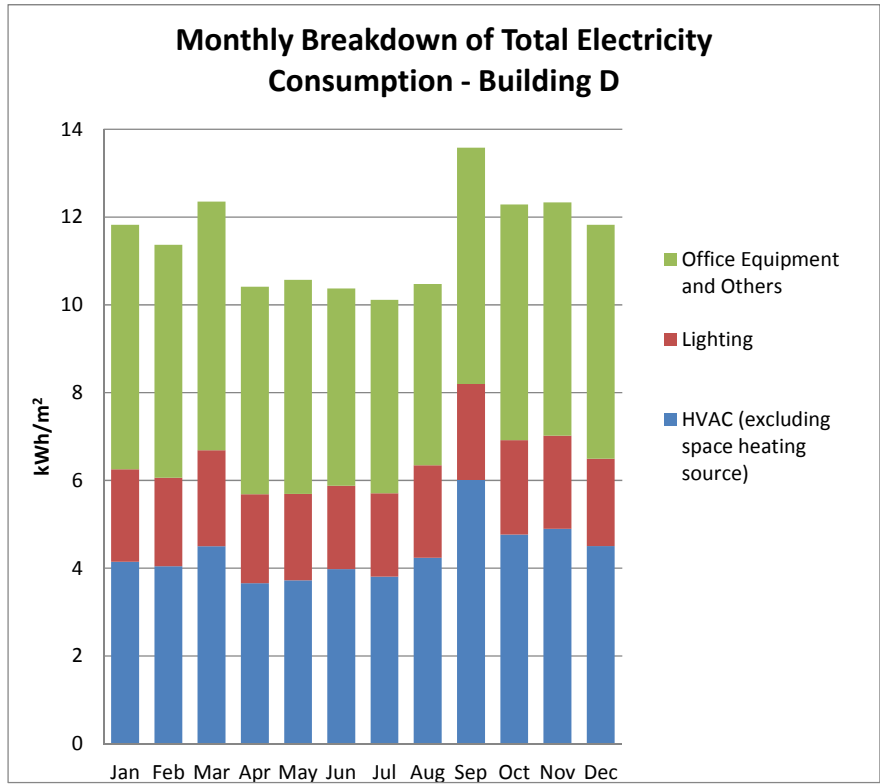

Figure 14 - Building D monthly electricity consumption.

As can be seen, the month-to-month changes in total electricity consumption of these buildings are mainly due to the changes of electricity consumed by HVAC, while the other subcategories, which are not weather related, stay relatively constant throughout the year. For the two Chinese buildings, A and B, district heating is provided from November 15 to March 15 of the following year. As shown in the Figures 11 and 12, electricity consumed by HVAC has a large increase during this period, due to the equipment related to space heating, such as AHU and pumps. Further investigation of occupant comfort or measurement of indoor air temperature would help to determine whether the building is overheated or the heating systems need retrofit. It can also be seen that less electricity is consumed during the transition season in April and October when heating is shut-down and little cooling is needed.

For the two U.S. buildings, Building C consumes more electricity in summer and less in winter, while Building D consumes the most in September, the hottest month of the year at this location, mainly caused by changes of HVAC energy. Unlike the Chinese buildings, Buildings C and D have no obvious HVAC increase in winter. In addition, it is curious that Building D's electricity use is higher in March than in the previous and following few months, while electricity use in July and August is much less than in September. This may be because the fourth floor was under retrofit and unoccupied from April to August in this year.

Weekly data analysis

Figure 15 is a comparison of total electricity consumption of the four buildings in a typical summer week. Since the hottest month for Building D is September, different from the usual summer months of July and August, a typical week was selected from September for Building D.

Though the data were collected at 15-minute time intervals for Buildings C and D, instead of the one-hour intervals for Buildings A and B, the latter interval is adopted for uniform comparison.

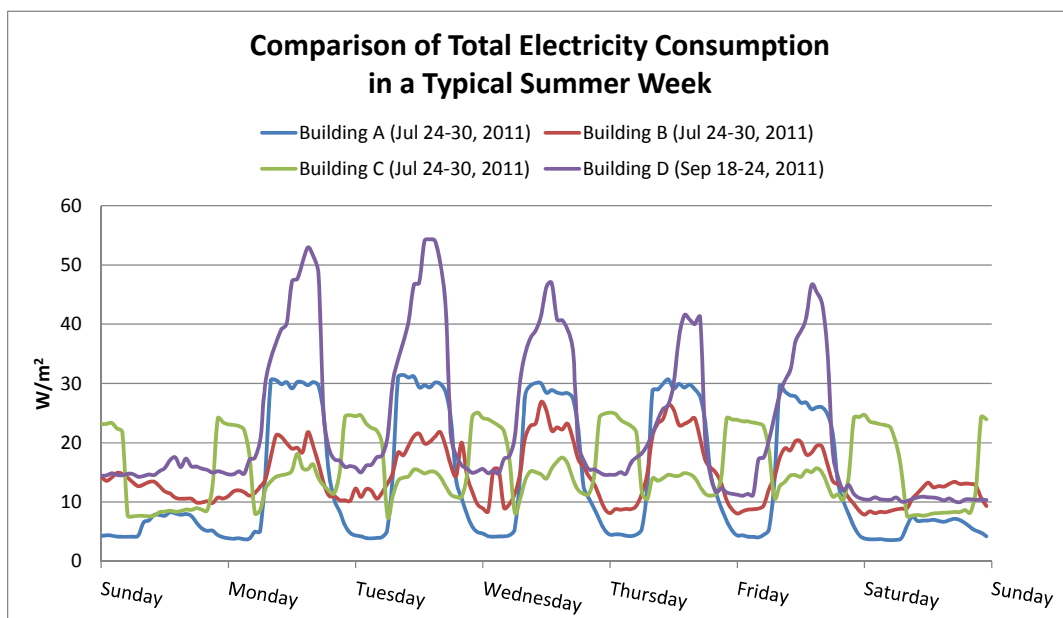

Figure 15 - Typical summer weekly comparison of total electricity consumption.

In terms of total electricity consumption in a typical week of the hottest period for each building, Building D is much higher than the other buildings in the daytime on weekdays, and also has a higher base load at night. Unlike the others, Building C consumes more at night and less during the day. This is a result of its district cooling system, in which the chillers and cooling towers work at night when electricity is cheaper, and supply chilled water during daytime on weekdays. The lower peak in daytime is caused by other normal electricity end uses.

To compare the difference between energy use on weekdays and weekends, it is important to calculate the ratio of average weekday energy use to the average weekend in the selected summer week for each building. In such calculations, each weekday or weekend consists of 24 hours of a whole day. The results are listed in Table 6.

Table 6 - Average weekday-weekend energy use ratio in a typical summer week.

Building	A	B	C	D
Average weekday-weekend energy use ratio	2.94	1.36	1.24	2.06

According to these ratios, Buildings A and D consume less electricity on weekends, and perform more efficiently throughout the whole week, though they may consume more on weekdays. However, the low ratio of Building C is mainly due to the district cooling equipment, which operates every night, including on weekends.

Daily data analysis

Further in depth, a typical weekday from each season was selected respectively for each building, to compare total electricity consumption. Typical weekdays in a same season were close to each other except for the special summer for Building D.

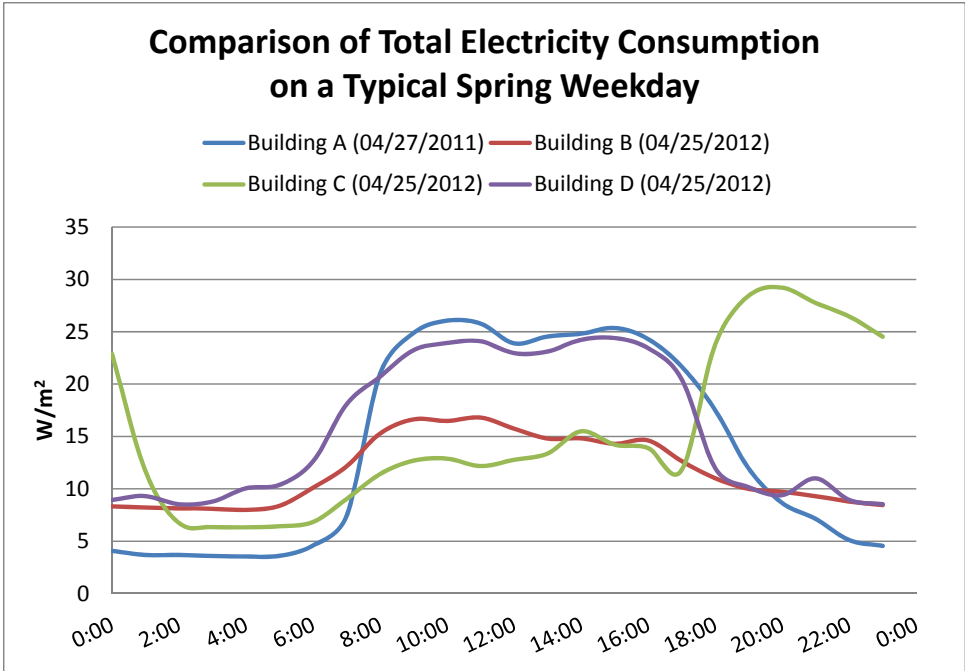

Figure 16 - Comparison of total electricity consumption on a typical spring weekday.

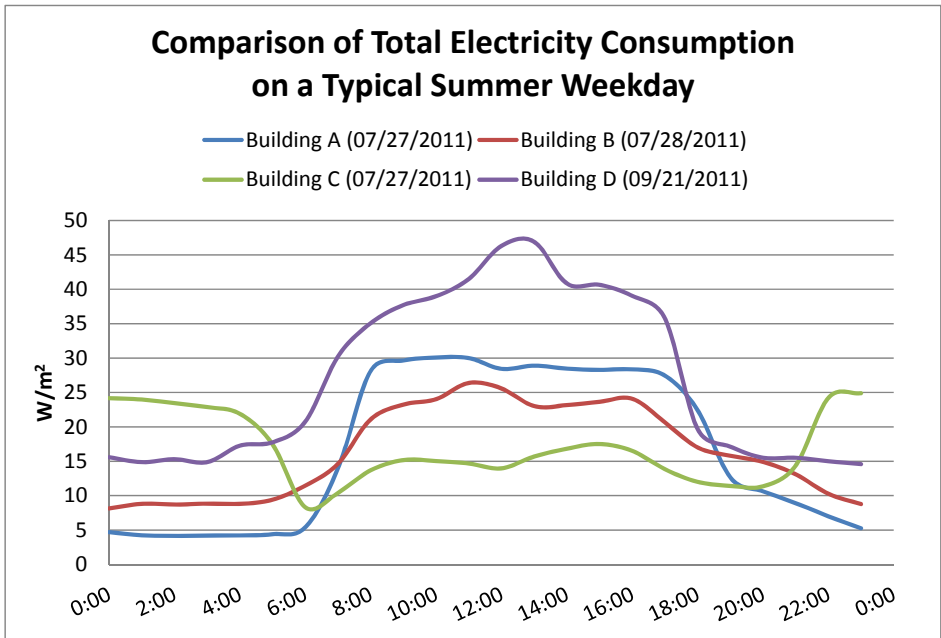

Figure 17 - Comparison of total electricity consumption on a typical summer weekday.

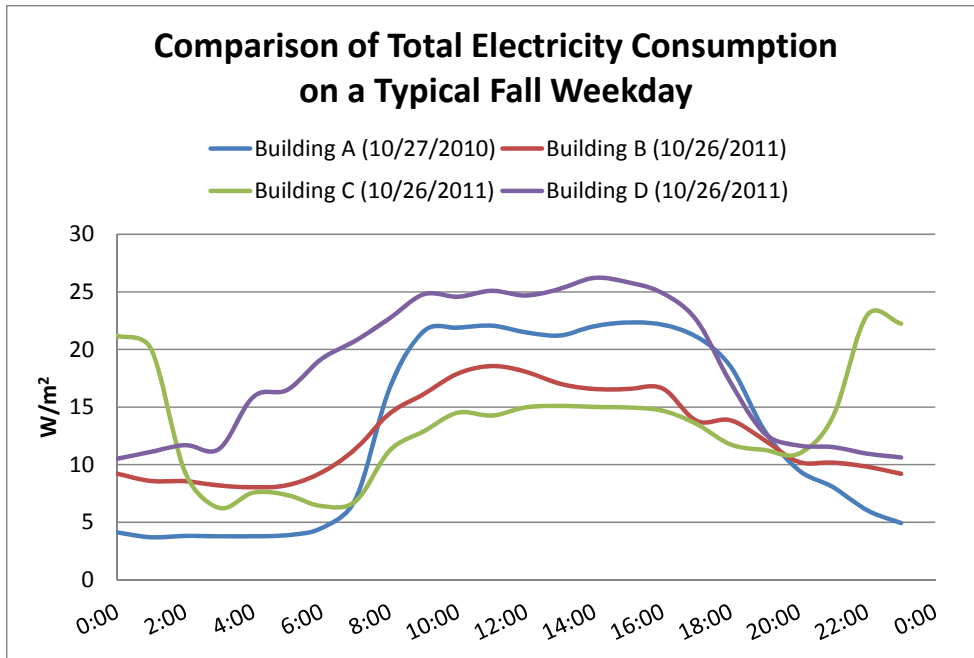

Figure 18 - Comparison of total electricity consumption on a typical fall weekday.

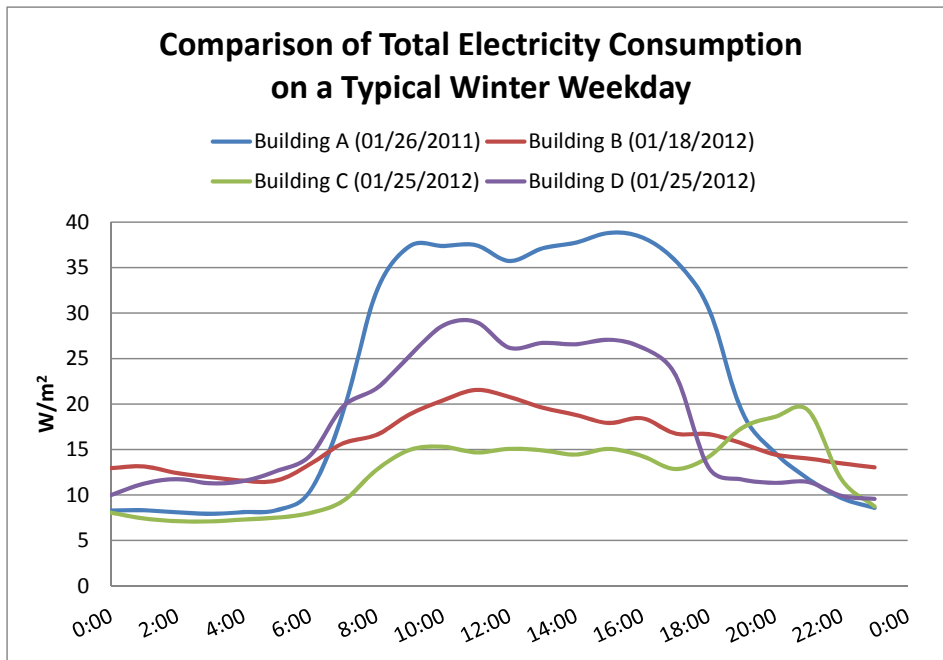

Figure 19 - Comparison of total electricity consumption on a typical winter weekday.

There are many important observations from these charts:

- Buildings A and D are always the top two in terms of peak electricity consumption in different seasons, but Building A has the lowest base power.

- Building A experiences a small decline in total electricity use during lunchtime on each typical weekday, which indicates Building A’s occupants are more conscious about turning off unnecessary appliances.
- According to the trends of the Building C’s curves, the district cooling system works longer on summer nights and is nearly out of use on winter nights.
- In terms of operation hours, regardless of the rough information provided by building managers, there appears to be no big difference among these buildings, except Building C, in any season, though it is not totally consistent every day.

According to Figures 16 to 19, 7:00~19:00 is taken as the operation period for Buildings A, B, and D for calculating peak demand of a day, and the remaining hours are used for base load calculation. The ratio of average peak load to average base load of these buildings on typical weekdays in each season was calculated and is shown in Table 7. The typical days selected here are the same as those in the above figures. Since Building C has a quite different pattern, it is not included into this comparison.

Table 7 - Peak-base energy use ratio on typical weekdays in four seasons.

	Spring	Summer	Fall	Winter
Building A	5.35	5.33	4.47	4.20
Building B	1.94	2.22	2.04	1.68
Building D	2.54	2.65	2.11	2.44

Building A clearly has a much higher peak-base energy-use ratio, especially in spring and summer, which indicates it consumes little electricity when there is no need, and thus it is more efficient and reasonable in electricity use throughout a whole day. Building B has the lowest ratio in every season, partly due to the large load of lighting at night. This may be a good reason for Building A’s lower total electricity consumption than Building B in some months, although it always consumes much more than Building B during the daytime.

Summary

From the above analysis and comparison, buildings may differ a lot in specific sub-items, yet at times seem similar on total electricity consumption. As for the four case-study buildings, the Chinese buildings consumed more electricity in lighting than did the U.S. buildings, contrary to the comparison between typical office buildings in both countries. More information is needed to determine whether the lighting systems in the Chinese buildings need retrofit.

For HVAC, the Chinese buildings experience a large increase in electricity use in winter due to heating-related equipment, while there is no such increase in the U.S. buildings. This may be a result of different climates, but there is still some need to determine whether the buildings are overheated or need retrofit. Decentralized HVAC systems appear to consume less energy than centralized systems. The lower temperature setpoint for cooling and more outdoor air required in most U.S. buildings may be a cause of their higher HVAC electricity use. Besides, old buildings with poor envelopes, like Building D, are more likely to consume more electricity in HVAC in general.

The two U.S. buildings, especially Building D, consume much more electricity in office equipment than the two Chinese buildings, due to more equipment and longer operation hours.

The peak-base energy use ratios of the buildings are quite different, probably due to different operation modes, manual management, and occupants' energy saving consciousness. It is clear that Building A performs much better in this aspect, and even has a small decline during lunchtime, which should be a good model for other buildings.

Discussion

Energy benchmarking for commercial buildings has always been difficult. Limiting the scope and normalizing discrepancies while taking into account case-specific circumstances are barriers to useful and proper analysis. However, this task can be made easier with correct data and necessary preparation before data analysis begins.

Some common challenges associated with benchmarking are discussed based on the real experiences from this study. In addition, some primary suggestions to try to overcome these challenges in the future are listed and discussed.

Data collection

A large number of commercial buildings in the U.S. have some kind of monitoring system installed. The newer buildings with Leadership in Energy and Environmental Design (LEED) certification require building monitoring as a part of the commissioning process. End-use-level detailed hourly or sub-hourly building energy monitoring, however, is rare and generally is provided only in buildings used for research. The authors investigated a large number of buildings that claimed to have building energy monitoring systems installed, and found that most of the buildings lacked component level detailed measurement; for example, plug-loads and lighting power were not metered separately. Hourly or sub-hourly data was unavailable in most of the buildings. Some buildings were installed with an EMCS that can monitor and/or control the lighting and equipment energy, heating and cooling energy, and other end uses as well as indoor temperature and humidity in real time. Unfortunately, some of those systems were not connected to a monitoring system to store the data for a longer period of time.

Another challenge was estimating the building's cooling and heating energy from district cooling and heating systems. Some buildings in this study are located on a large campus and connected to a district cooling and heating system. For a consistent comparison with all other buildings, the cooling and heating energy for the selected buildings had to be separated from the total plant's energy, but this could only provide a rough estimate of the building's cooling and heating energy.

Data sharing

Once a few buildings with a reasonable amount of detailed measurement data were selected, a major challenge was data sharing. None of the building owners or facility managers was willing to share their measured building energy data. This challenge was overcome by personal discussions with facility managers, site visits, nondisclosure agreements, and by the promise to share analysis

results and identify retrofit measures. The research team also provided the funding for additional metering, where lacking.

It is vitally important to communicate with building managers before such a project actually starts, to gain deeper information and let building managers know their responsibilities throughout the monitoring process.

Data retrieval

When database access is allowed, it is still a labor-intensive procedure to download and export data to researchers' computers. Some systems need certain computer language to retrieve and export the data of every useful data point, which can take a long time. The difficulty level of such work depends on the technical features of the energy-monitoring system. Improvements to data retrieval, downloading, and exporting features would ease data acquisition and result in fewer manual errors.

Although raw data are sampled at short intervals by the monitoring systems, such as five-minute or even less, the time intervals of the data available for downloads can be different, depending on what time intervals are used in the post-processing of the raw data. In this study, the post-processed 15-minute interval data were downloaded for the two U.S. buildings, while the one-hour interval data for the two Chinese buildings.

Naming of data points

The benefits of consistent and useful data point names in BAS are becoming more apparent as computerized systems containing hundreds or thousands of points are deployed in commercial buildings. Well-chosen point names can provide useful information about installed systems and make it easier to monitor, retrieve and download, analyze, maintain, modify, and interconnect data of various building systems. Software that performs automated analysis of HVAC system performance may benefit from consistent application of a point-naming standard (Butler & Veelenturf, 2010).

Missing data

Generally, obtaining complete sets of data is by far the largest barrier for benchmarking and analysis of energy use of commercial buildings. Most of the selected buildings have some missing data, and there seems no pattern to which meters might lose data during what time periods. The causes of missing data vary. U.S. buildings have a high frequency of missing energy data around weekends and missing condition data at night, suggesting the monitoring system is sometimes out of use when no one is in charge.

Chinese buildings' biggest problems lie in the connectivity between meters, database, and online system. When connection is lost, all data is lost for all equipment.

Meter instability may cause occasional individual missing data, while large sets of missing data may be caused by the retrofit of either the monitoring system itself or energy service system (like HVAC or lighting), or even by power failure in the buildings, during which the meters don't measure, the connection is lost, and even the computer is out of power, leaving missing data in the database. To

avoid these problems requires higher quality meters, sensors, nonstop operation of the monitoring system, and better emergency measures when power is out and connection is lost.

Data quality

Even if the data obtained are complete, data quality may suffer, mainly due to the uncalibrated or broken meters or sensors. Some invalid data — such as negative values and abnormally mutational findings — can easily be detected, while some seemingly normal data may actually be inaccurate, considering the error of measurement. Higher quality meters and sensors, along with more frequent maintenance, would avoid these problems.

Moreover, it is possible for invalid data to appear during the downloading and exporting process, especially when exporting a large set of data at one time. A higher quality data transmission system may avoid this possibility.

Data correction

To get the data in workable order for calculation, analysis, and benchmarking, the missing or invalid (mainly negative) data should be replaced with data during time periods or days that were similar to the invalid points, taking weather condition into account as well. For example, a few missing data would be replaced by the previous or following few proper data, or their average. Several hours' missing data would be replaced by data of the same time periods on the previous or following day, taking into account weekdays and weekends. The same goes for missing or invalid data of an even longer period.

Data analysis

Analyzing and comparing more than a year's complete and corrected sub-metered energy data is a big challenge. Although the importance of data analysis is well acknowledged, there is still no standard for it. Some methods are used and some charts are presented in this project for better and deeper analysis and benchmarking, through which we have achieved some basic understanding of the difference of energy use between buildings in the U.S. and China. However, more research is needed to develop a standard and widespread methodology for building energy data analysis and benchmarking.

Conclusions

Existing energy monitoring platforms lack an industry standard in the whole process of data collection and analysis. Especially, a standard data model is needed to describe the hierarchy of energy end uses in buildings to support energy profiling, benchmarking, and diagnostics. Good data is the foundation of building energy research. It requires better and uniform methods to deal with all the issues involved in data collection, sharing and retrieval, naming of data points, and handling of missing and poor quality data.

The detailed data analysis and benchmarking of the four office buildings demonstrated that buildings in the U.S. and China performed very differently, had deep potential for energy savings, but different efficiency measures should apply.

References

- Architecture 2030 (2012). <http://architecture2030.org/>. Accessed on September 26, 2012.
- Akihiro, H. & Mitsuhiro, K. (2012). Smart buildings (BEMS) to optimize the energy supply and demand control of buildings. *NEC Technical Journal*, 7(1), 82-86.
- BECSS (2007). Beijing municipal government office buildings and large public building energy consumption statistical summary. In Chinese.
- Brown, N., Wright, A. J., Shukla, A., & Stuart, G. (2009). Longitudinal analysis of energy metering data from non-domestic buildings. *Building Research & Information*, 38:1, 80-91.
- Butler, J.F. & Veelenturf, R. (2010). Point naming standards. *ASHRAE Journal*, November issue.
- Dong, B., Lee, S.E., & Sagar, M.H. (2005) A holistic utility bill analysis method for baselining whole commercial building energy consumption in Singapore. *Energy and Buildings*, 37, 167-174.
- Eom, J., Clark, L.E., & Kim, S.H. (2012). China's building energy use: A long-term perspective based on a detailed assessment. *PNNL Report*, PNNL-21073.
- Granderson, J. (2012). *Monitoring-based commissioning: Continuous performance investigation and evaluation*. Presented at Lawrence Berkeley National Laboratory, Berkeley, CA.
- Granderson, J., Piette, M.A., Rosenblum, B., Hu, L., et al. (2011). *Energy information handbook applications for energy efficient building operations*. Lawrence Berkeley National Laboratory, Technical Report, LBNL-5272E.
- Green Building Research Center, UC Berkeley (2008). Best Practices Case Study.
- Healey, W.M. (2010). *Measurement challenges in achieving energy monitoring systems in buildings*. NIST Technical Note, TN-1656.
- Hong, T. (2009). A close look at the China Design Standard for Energy Efficiency of Public Buildings. *Energy and Buildings*, 41, 426-435.
- IEA (2007). *Energy balances of OECD/non-OECD countries*.
- IEA (2009-2012). *ECBCS Annex 53: Total energy use in buildings – analysis and evaluation methods*.
- ISO (2012). Standard 12655: Energy performance of buildings — presentation of real energy use of buildings.
- Jiang, Y. (2012). China gives green light to building energy reductions combining energy conversation technologies with green lifestyle. *IEA ECBCS News*, 55.
- Kinney, S. & Piette, M.A. (2002). *Development of a California commercial building energy benchmarking database*. Proceedings of the 2002 ACEEE Summer Study on Energy Efficiency in Buildings.

LBNL (2012). EnergyIQ. <http://energyiq.lbl.gov/>. Accessed on September 26, 2012.

Mills, E., Bourassa, N., Piette, M.A., Friedman H., Haasl, T., Powell, T., & Claridge, D. (2005). *The cost effectiveness of commissioning new and existing commercial buildings: Lessons from 224 buildings*. Proceedings of the 2005 National Conference on Building Commissioning.

Mlecnik, E., Bossaer, A., Coolen, J., et al. (2003). Benchmarking of energy use in Belgium. *Energy and the Environment*, 7, 113-122.

Noreacuten, A. (2010). The first step to cost savings: Smart building power management automation. *Building Services & Environmental Engineer*, 28(70).

Piette, M.A., Kinney, S., & Haves, P. (2001). Analysis of an information monitoring and diagnostic system to improve building operations. *Energy and Buildings*, 33, 783–791.

Sartor, D., Piette, M.A., Tschudi, W., et al. (2000). *Strategies for energy benchmarking in cleanrooms and laboratory-type facilities*. Proceedings of the 2000 ACEEE Summer Study on Energy Efficiency in Buildings.

UNEP (2009). Buildings and climate change, summary for decision-makers.

U.S. Department of Energy, (USDOE 2008). *Energy efficiency trends in residential and commercial buildings*. October 2008.

Acknowledgement

This work was sponsored by the U.S. Department of Energy under the U.S.-China Clean Energy Research Center for Building Energy Efficiency, and the China Ministry of Housing and Urban-Rural Development and the Ministry of Science & Technology. Special thanks to the U.S. and China CERC-BEE management, our industry partners, the Industry Advisory Board, and the Technical Advisory Committee for the strong support on the project.

Appendix A – List of Publications

Journal Articles

1. X. Ren, S. Hu, D. Yan, C. Peng. Development of energy models for residential appliances based on measured data. *Building Science*, 28(S2), 2012. In Chinese.
2. Q. Shen, J. Xia, Y. Jiang. Development of models on energy sub-metering of large public buildings. *Building Science*, 28 (S2), 2012. In Chinese.
3. Q. Shen, J. Xia. How energy management platform can save energy and increase energy efficiency. *Intelligent Buildings*, 3:43-46, 2011. In Chinese.
4. J. Xia, T. Hong, Q. Shen, W. Feng, L. Yang, P. Im, A. Lu, M. Bhandari. Comparison of Building Energy Use Data between the United States and China, *Energy and Buildings*, 2013. Under reviewed.
5. T. Hong, L. Yang, D. Hill, W. Feng. Data and Analytics to Inform Energy Retrofit of High Performance Buildings, *Applied Energy*, 2014. Accepted.

Conference Papers

1. Q. Shen, J. Xia, Y. Jiang. A case study on energy performance and retrofitting technologies for a high standard resort hotel. the 7th International Symposium of Heating, Ventilation and Air-conditioning, Shanghai, 2011.
2. Qi Shen, Alison Lu, Jianjun Xia, Daily Energy Consumption Density Analyzing Method for Hourly Data Monitoring System, Proceeding of The Second International Conference on Building Energy and Environment, August 1-4, 2012, Boulder, Colorado.
3. T. Hong, L. Yang, J. Xia, W. Feng. Building Energy Benchmarking between the United States and China: Methods and Challenges, ISHVAC 2013, Xi'an, China, 2013.

Appendix B – List of Workshops and Major Activities

Workshops/Activities	Date and Location	Summary
CERC Conference	1/19-20/2011, DOE, USA	CERC Kickoff meeting
CERC-BEE Conference	3/24-25/2011, Tsinghua, China	Research teams from both countries and CERC management attended to discuss the research plan and scope of work etc.
Project Kickoff Meeting	7/22/2011, LBNL, USA	About 24 people attended the meeting, including the LBNL and Tsinghua research teams, industry partners, DOE, and researchers from other institutes. Research objectives, plan and deliverables were presented and discussed.
Industry Advisor Board Meeting	8/16/2011, LBNL, USA	The LBNL Team presented research progress and addressed comments and questions from IAB.
CERC Management visited Tsinghua	9/21/2011, Tsinghua, China	The Tsinghua Team reported research progress and had broader discussion with US CERC directors, Robert Marley and Michaela Martin, to plan and improve the next step.
Project Progress Meeting	12/27/2011, Tsinghua, China	The LBNL and Tsinghua research teams had a one-day meeting to exchange and discuss research progress and address issues.
China CERC-BEE Annual Review	1/10/2012, ShenZhen, China	China CERC-BEE Annual Review. The Tsinghua Team presented the research work and addressed comments and questions from reviewers.
US CERC-BEE Technical Review	2/14/2012, DOE, USA	The LBNL Team presented joint research progress and addressed comments and questions from CERC reviewers and management.
Industry Advisor Board Meeting	3/20/2012, LBNL, USA	The LBNL Team presented joint research progress and addressed comments and questions from IAB.
Joint CERC-BEE	7/18-20, Sanya,	The LBNL and Tsinghua Teams presented the

Annual Conference	China	research results and addressed comments and questions from reviewers and CERC management.
Project Progress Meeting	11/29/2012, Tsinghua, China	The LBNL and Tsinghua research teams had a one-day meeting to exchange and discuss research progress and address issues.
CERC Technical Review	12/3/2012, LBNL, USA	The LBNL research presented the research results and addressed comments and questions from the CERC TAC (Technical Advisor Committee).

Appendix C – Sourcebook of Case Study Buildings: Description

SOURCE BOOK

Description of Case Study Buildings in the U.S. and China

U.S.-China Clean Energy Research Center on Building
Energy Efficiency (CERC-BEE)

November, 2012

Table of Contents

| Summary of Case Buildings

| Development Building

1. Location and Climate
2. Building Description
3. Building Monitoring System

| Ministry of Agriculture

1. Location and Climate
2. Building Description
3. Building Monitoring System

| Tsinghua University Humanities Library

1. Location and Climate
2. Building Description
3. Building Monitoring System

| Tsinghua University School of Environment

1. Location and Climate
2. Building Description
3. Building Monitoring System

| Tsinghua University School of Art

1. Location and Climate
2. Building Description
3. Building Monitoring System

| University of California-Merced Library Office Wing

1. Location and Climate
2. Building Description
3. Building Monitoring System

| Lawrence Berkeley National Laboratory: Building 90

1. Location and Climate
2. Building Description
3. Building Monitoring System

| California State Teachers' Retirement System (CalSTRS)

1. Location and Climate
2. Building Description
3. Building Monitoring System

| **Georgia Institute of Technology:**

G. Wayne Cough Undergraduate Learning Commons (CULC)

1. Location and Climate
2. Building Description
3. Building Monitoring System

| **EPA: National Computer Center (NCC)**

1. Location and Climate
2. Building Description
3. Building Monitoring System

Summary of Case Buildings

1. Building Locations

China

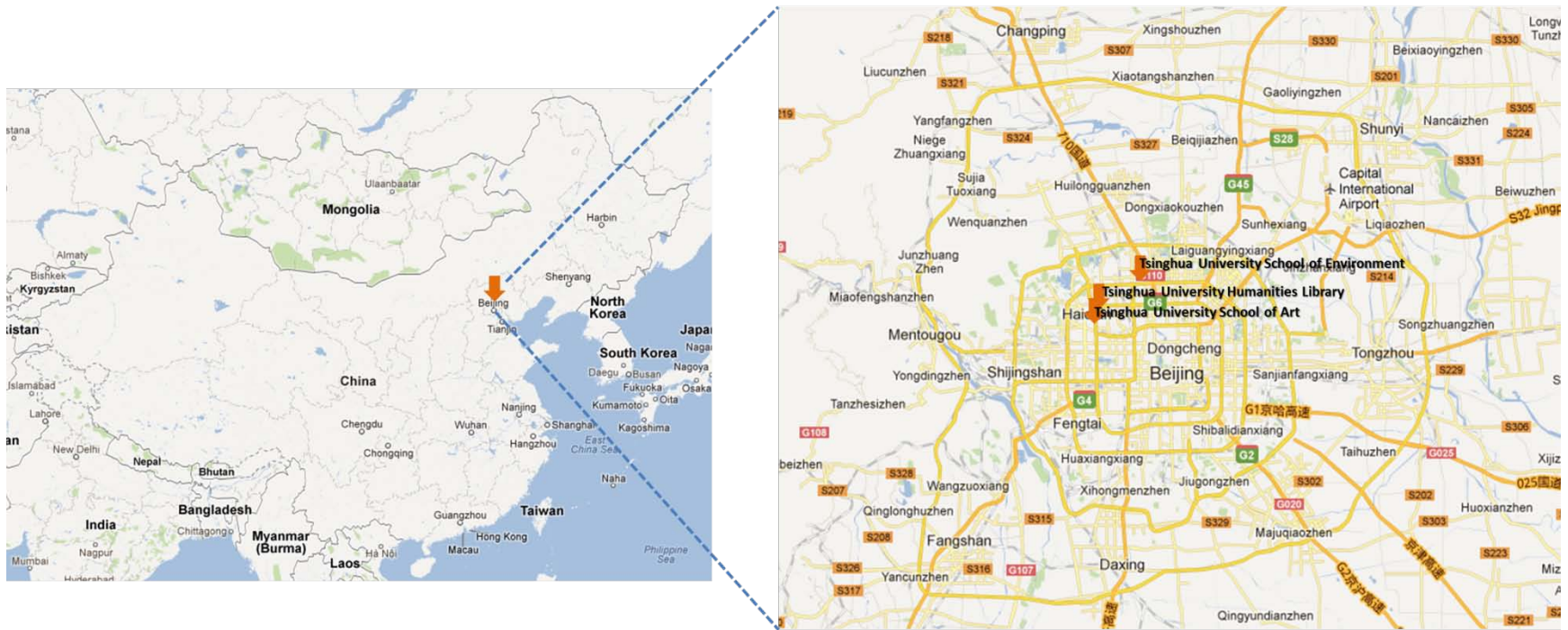

Figure 1 China Case Building Locations

U.S.







Figure 2 US Case Building Locations

2. Building Summary

Table 1 Case Buildings Summary

No.	Name & Picture	Function	Location	Size	Year Built	Description of HVAC Systems
1	Development Building 	Office	Beijing, China	54,490 m ² (586,525 ft ²)	1989	Water-cooled chiller, district heating, VAV + CAV systems
2	Ministry of Agriculture 	Office	Beijing, China	39,211 m ² (422,063 ft ²)	1987	Decentralized AC for cooling, district heating
3	Tsinghua University Humanities Library 	Library	Beijing, China	20,000 m ² (215,278 ft ²)	2011	Water cooled chiller Local VRV units Campus heating network Terminal: FCU+AHU
4	Tsinghua University School of Environment 	Office and Laboratory	Beijing, China	20,300 m ² (218,507 ft ²)	2006	Water cooled chiller Campus heating network Terminal: Radiator + OA 2 AHU
5	Tsinghua University School of Art 	Office, Class rooms, and Exhibition Area	Beijing, China	63,940 m ² (688,244 ft ²)	2005	Water cooled chiller Campus heating network Terminal: FCU+AHU
6	UC-Merced Library Office Wing 	Office and Library	Merced, CA	16,000 m ² (172,222 ft ²)	2005	District cooling, district heating, AHU + VAV systems

7	LBNL Building 90		Office	Berkeley, CA	8,316 m ² (89,513 ft ²)	1960	Local electric cooling and gas-boiler heating Centralized and packaged DX systems
8	CalSTRS Headquarters		Office and Podiums	Sacramento, CA	34,374 m ² (370,000 ft ²)	2009	WSHP, Water cooled chillers Built-up VAV Terminal: VAV box, perimeter electric reheat (f-p boxes), UFAD
9	George Tech G. Wayne Cough Undergraduate Learning Commons (CULC)		Class rooms and Auditoria	Atlanta, GA	23,225 m ² (249,991 ft ²)	2012	District Cooling and Heating Terminal: AHU+VAV
10	EPA National Computer Center (NCC)		Office and Data Center	Durham, NC	9,376 m ² (100,890 ft ²)	2001	District Cooling Local Heating (2 boilers) Terminal: VAV for Office

Development Building

1. Location and Climate

Location: Beijing, China

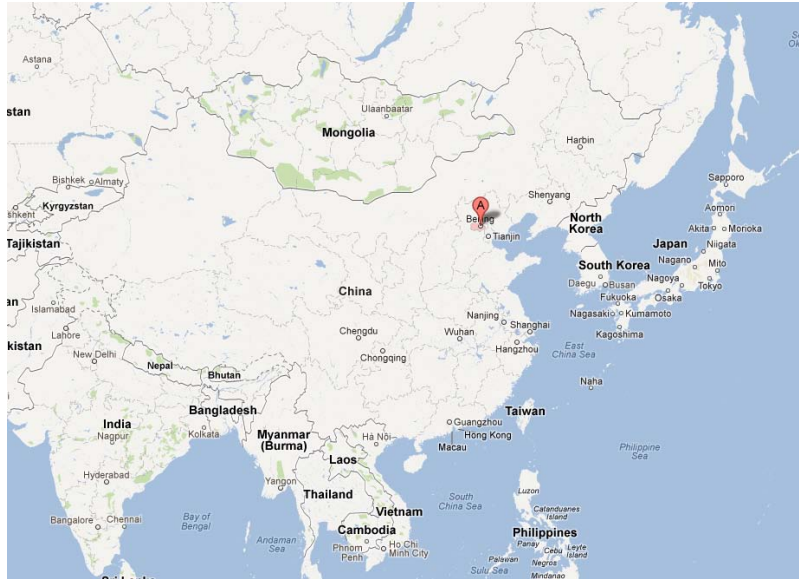

Figure 3 Sub-metering Project in Beijing Location

Climate

Table 2 Climate Data (Beijing, China)

Month	Unit	Jan	Feb	Mar	Apr	May	Jun	Jul	Aug	Sep	Oct	Nov	Dec	Year
Average High	°C	1.8	5.0	12	20	26	30	31	30	26	19	10	3.7	18
	°F	35	41	53	69	79	86	88	86	78	66	50	39	64
Average Low	°C	-8.4	-5.6	0.4	7.9	14	19	22	21	15	7.9	0.0	-5.8	7.2
	°F	17	22	33	46	57	66	72	69	59	45	32	22	45
Precipitation	mm	2.7	4.9	8.3	21	34	78	185	160	46	22	7.4	2.8	572
	inches	0.1	0.2	0.3	0.8	1.3	3.1	7.3	6.3	1.8	0.9	0.3	0.1	23

Source: China Meteorological Administration (1971-2000)

The same goes for the other case buildings in Beijing, China.

2. Building Description



Figure 4 Development Building

Table 3 Development Building Specification

Category	Item name	Descriptions
Building information	Name	Development Building
	Location	Beijing, China
	Year of construction	1989
	Climate zone	ASHRAE Climate Zone 4B
	Type	Office
	number of floor	21
	Floor area (m ²)	54,490 m ² (586,525 ft ²)
	Conditioned area (m ²)	30,300 m ² (326,147 ft ²)
	Operation hours	M-F 7 a.m.-6 p.m.
Max. Occupancy	1800 people	
Building Envelope	Window	Double monochromatic vacuum glass curtain wall
HVAC	cooling system	Centralized HVAC
	heating system	City district heating
	Air system	VAV + CAV
	Room set-point	Cooling: 24-26°C, Heating: 22-24°C
	Control system	Johnson Controls
	operation hours	7 a.m.-6 p.m.
Control & Monitoring	EMS	Johnson Controls
	Energy Monitoring system	iSagy

3. Building Monitoring System

Since the case buildings in China have the same energy monitoring system - iSagy, they share the same energy data model as shown in Figure 5. The data exported from the database are well calculated and listed by different nodes in this model, at a one-hour time interval. The same goes for the other case buildings in China.

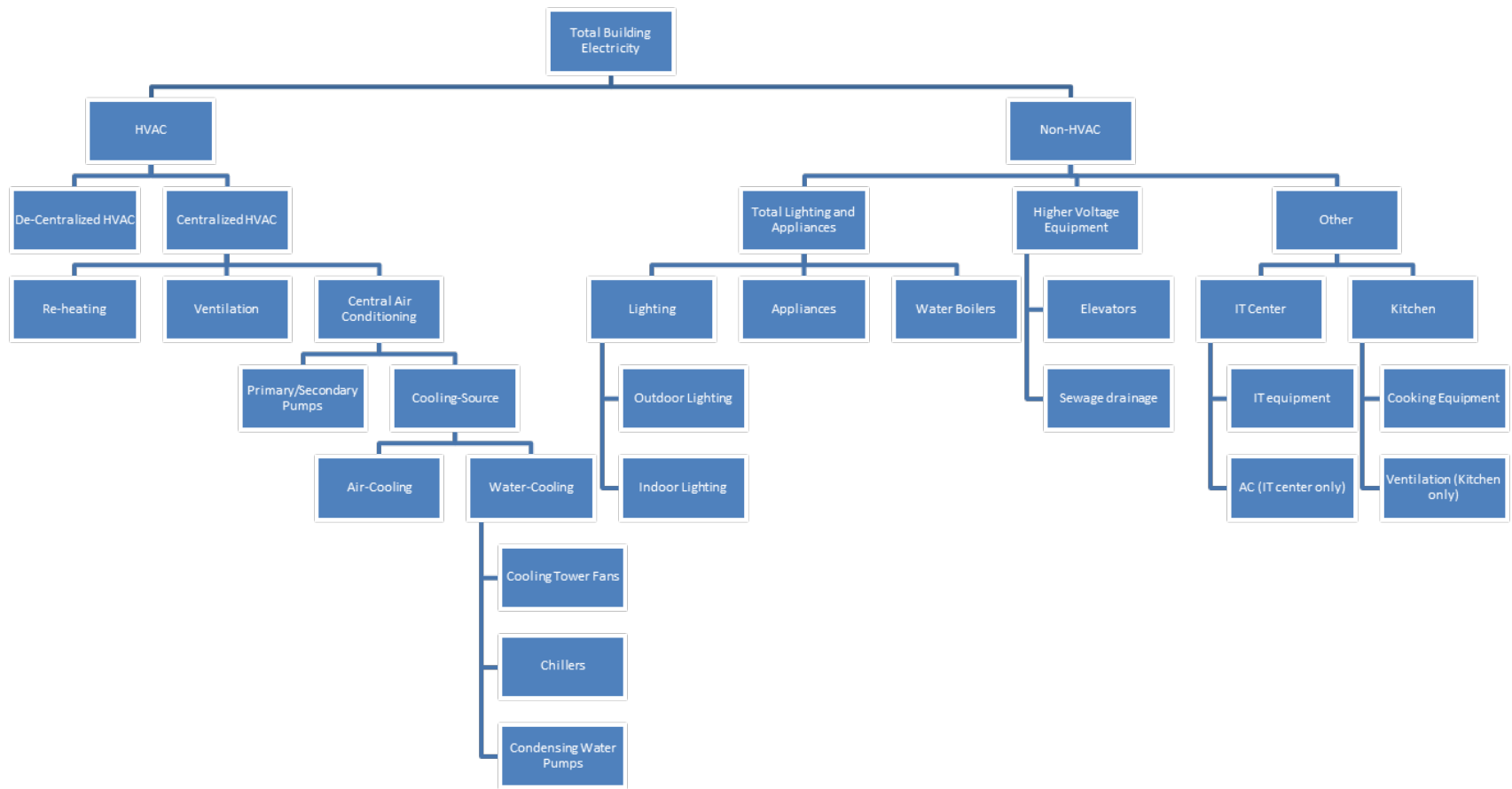

Figure 5 Energy Data Model of Case Buildings in China

This specific building’s monitoring structure is shown in Figure 6. Monitoring points are listed under corresponding transformers, with the numbers of points for same sub-items. Some points have more than one sub-item, such as “Lighting & Appliances” and “Misc.,” which were separated in data center according to specific algorithms.

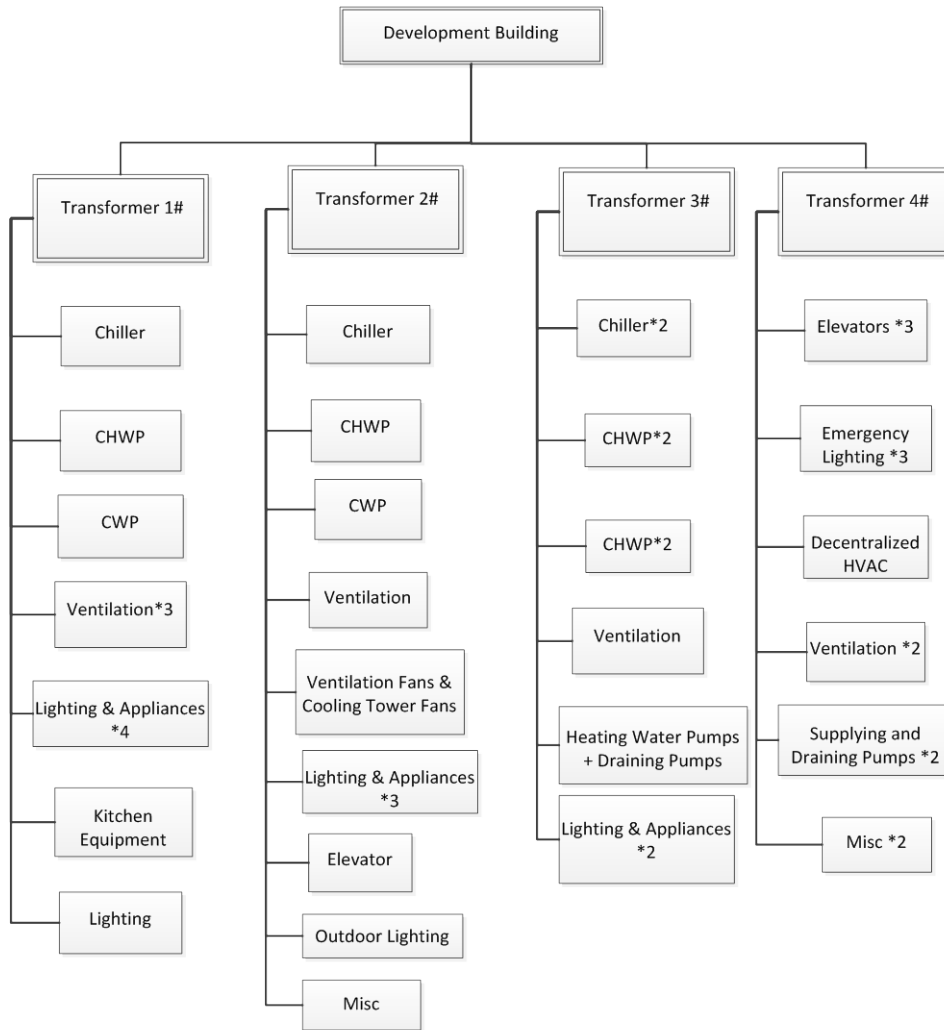

Figure 6 Development Building Monitoring Structure

Ministry of Agriculture

1. Location and Climate

Location: Beijing, China. See Figure 3

Climate: see Table 2

2. Building Description



Figure 7 Ministry of Agriculture

Table 4 Ministry of Agriculture Building Specification

Category	Item name	Descriptions
Building information	Name	Ministry of Agriculture
	Location	Beijing, China
	Year of construction	1987
	Climate zone	ASHRAE Climate Zone 4B
	Type	Office
	number of floor	11
	Floor area (m ²)	39,211 m ² (422,063 ft ²)
	Conditioned area (m ²)	
Operation hours	M-F 6 a.m.-6 p.m.	
HVAC	cooling system	Decentralized HVAC
	heating system	City district heating
	Air system	N/A
Control & Monitoring	Energy Monitoring system	iSagy

3. Building Monitoring System

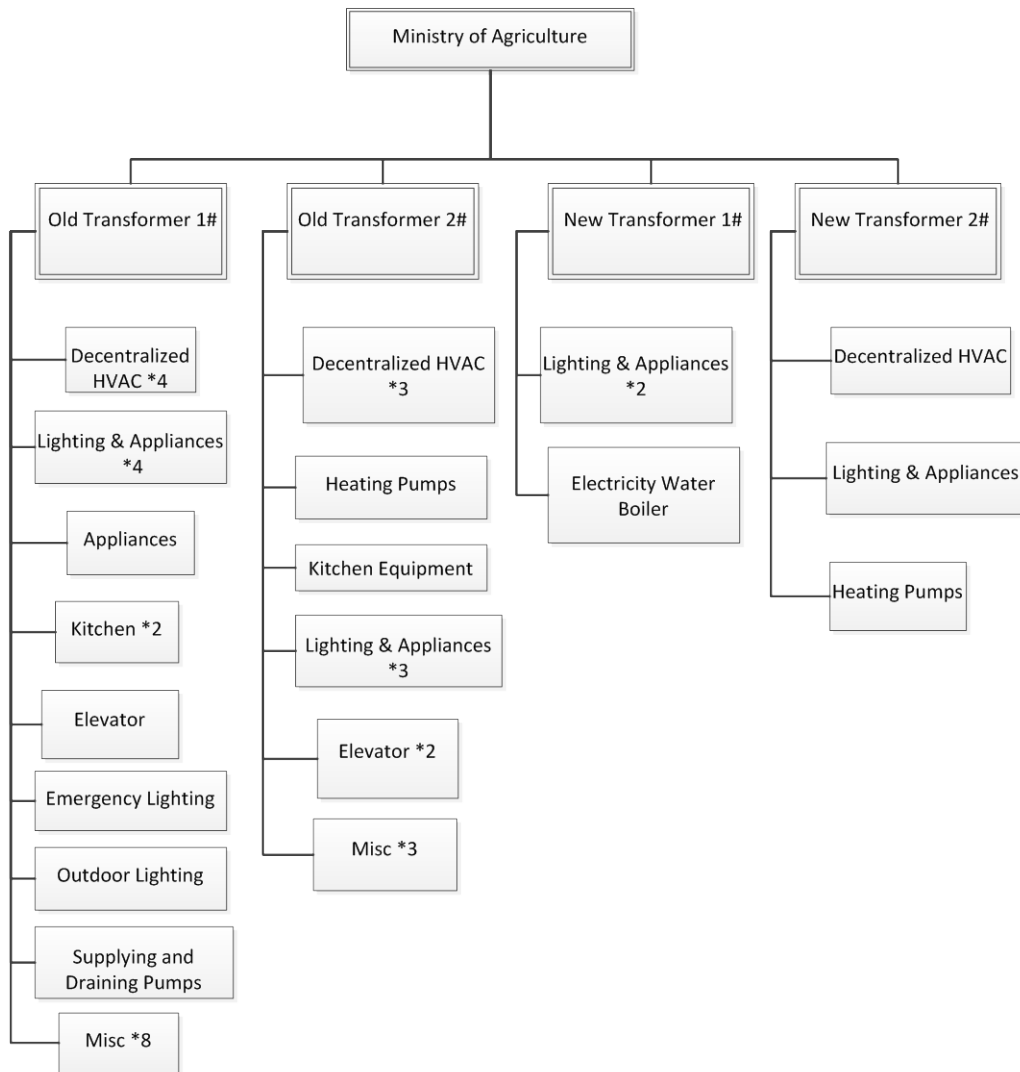

Figure 8 Ministry of Agriculture Monitoring Structure

Humanities Library, Tsinghua University

1. Location and Climate

Location: Beijing, China. See Figure 3

Climate: see Table 2

2. Building Description



Figure 9 Humanities Library

Table 5 Humanities Library Building Specification

Category	Item name	Descriptions
Building information	Name	Humanities Library
	Location	Beijing, China
	Year of construction	2011
	Climate zone	ASHRAE Climate Zone 4B
	Type	Library
	number of floor	7
	Floor area (m ²)	20,000 m ² (215,278 ft ²)
	Conditioned area (m ²)	12,000 m ² (129,166 ft ²)
	Operation hours	7:00am - 10:30pm
Max. Occupancy	1000 people	
HVAC	cooling system	Centralized HVAC
	heating system	Campus district heating
	Air system	VRV, AHUS
Control & Monitoring	Energy Monitoring system	iSagy

3. Building Energy Monitoring System

Below is a diagram of monitoring points according to transformer. Unless noted in parenthesis next to it, there is one meter for each piece of equipment.

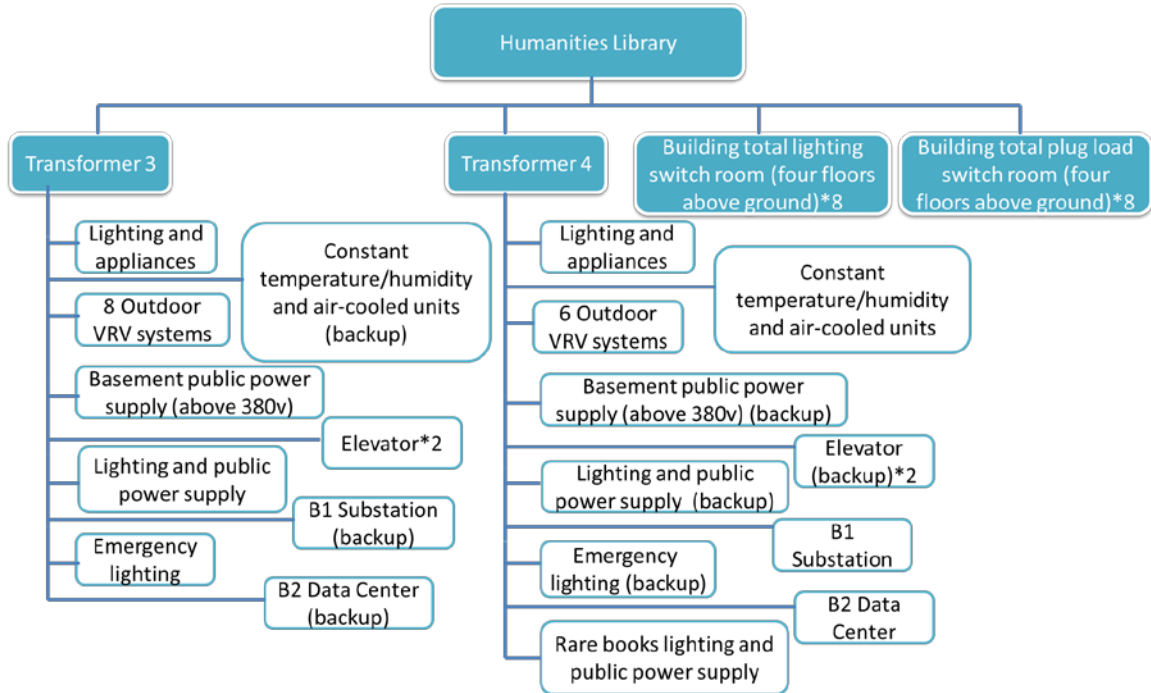

Figure 10 Tsinghua University Humanities Library Monitoring Structure

School of Environment, Tsinghua University

1. Location and Climate

Location: Beijing, China. See Figure 3

Climate: see Table 2

2. Building Description



Figure 11 School of Environment

Table 6 School of Environment Building Specification

Category	Item name	Descriptions
Building information	Name	School of Environment
	Location	Beijing, China
	Year of construction	2006
	Climate zone	ASHRAE Climate Zone 4B
	Type	Offices, Laboratory
	number of floor	12
	Floor area (m ²)	20,300 m ² (218,507 ft ²)
	Conditioned area (m ²)	12,000 m ² (129,167 ft ²)
	Operation hours	7:00am – 10:30 pm
	Max. Occupancy	1000 people
HVAC	cooling system	Centralized HVAC
	heating system	Campus district heating
	operation hours	8:00am - 5:00pm
Control & Monitoring	Energy Monitoring system	iSagy

3. Building Monitoring System

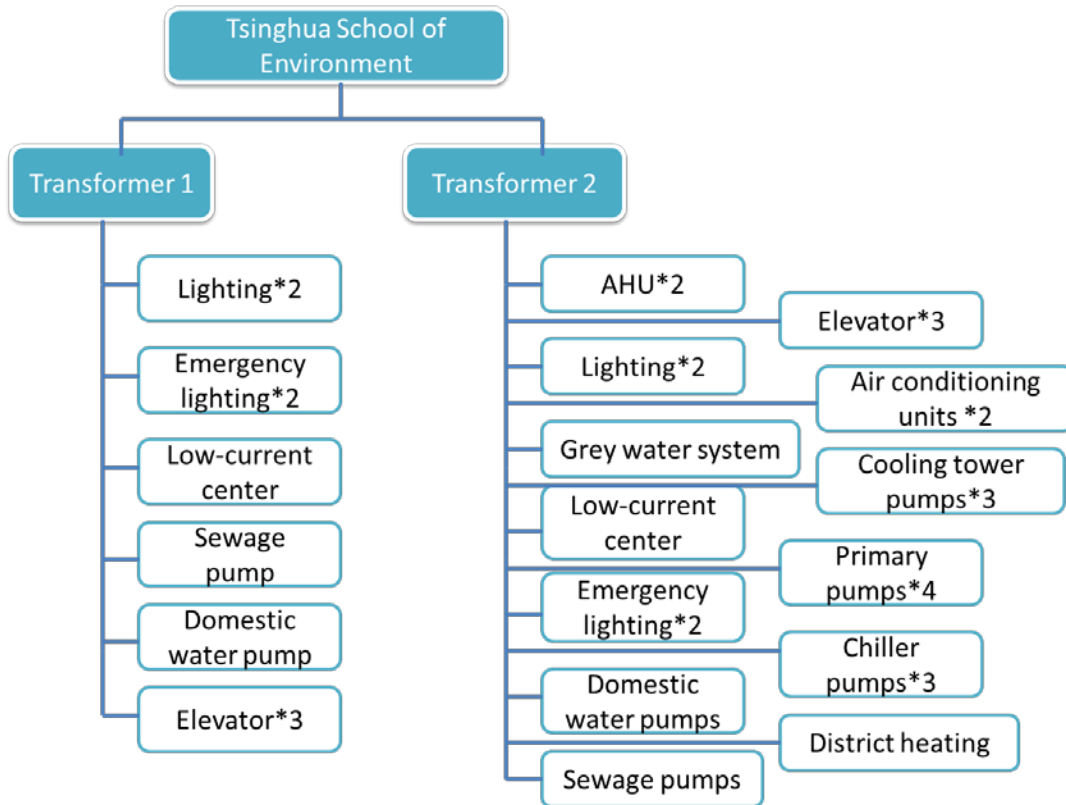

Figure 12 Tsinghua University School of Environment Monitoring Structure

School of Art, Tsinghua University

1. Location and Climate

Location: Beijing, China. See Figure 3

Climate: see Table 2

2. Building Description



Figure 13 School of Art

Table 7 School of Art Building Specification

Category	Item name	Descriptions
Building information	Name	School of Art
	Location	Beijing, China
	Year of construction	2005
	Climate zone	ASHRAE Climate Zone 4B
	Type	Office, Classrooms, Exhibition Area
	number of floor	6
	Floor area (m ²)	63,940 m ² (688,244 ft ²)
	Conditioned area (m ²)	49,250 m ² (530,122 ft ²)
	Operation hours	7:00am - 10:30pm
	Max. Occupancy	2000 people
HVAC	cooling system	Centralized HVAC
	heating system	Campus district heating
	Air system	Fan Coil Units, AHUs
	operation hours	8:00am - 5:00pm
Control & Monitoring	Energy Monitoring system	iSagy

3. Building Monitoring System

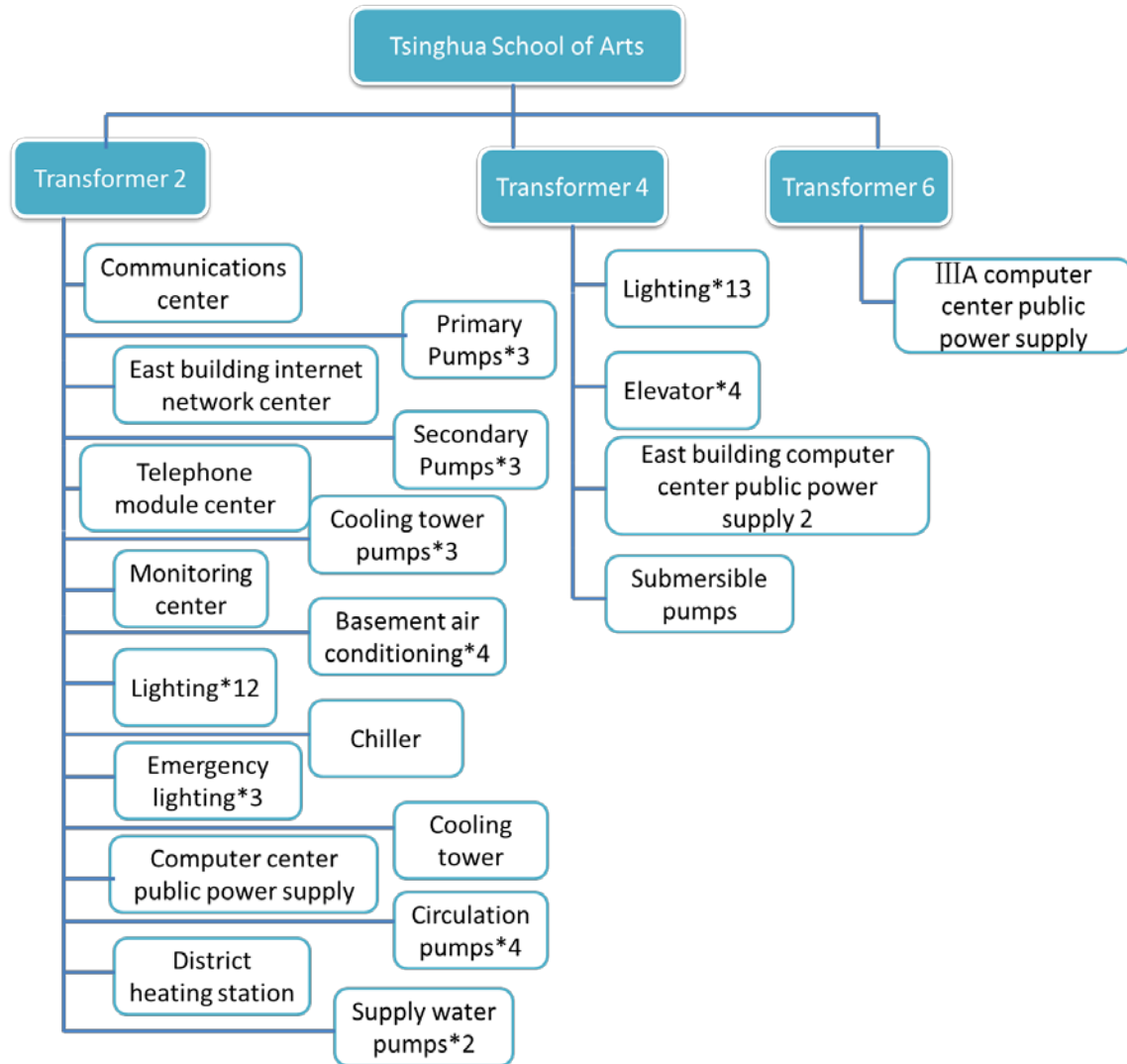

Figure 14 Tsinghua University School of Art Library Monitoring Structure

Office Wing of University of California-Merced Library

1. Location and Climate

Location



Figure 15 UCM Library Office Wing Location

Climate

Table 8 Climate Data (Merced, CA)

Month	Unit	Jan	Feb	Mar	Apr	May	Jun	Jul	Aug	Sep	Oct	Nov	Dec	Year
Average High	°C	13	16	20	24	28	33	36	35	32	27	19	13	25
	°F	55	62	67	74	83	91	97	95	90	80	66	56	76
Average Low	°C	2.2	3.7	5.1	7.1	10	14	16	15	13	8.4	4.2	2.1	8.4
	°F	36	39	41	45	51	56	61	59	55	47	40	36	47
Precipitation	mm	63	55	49	28	11	2	0.3	0.5	4	15	35	48	312
	inches	2.5	2.2	1.9	1.1	0.4	0.1	0.01	0.02	0.2	0.6	1.4	1.9	12

Source: Merced Regional Airport-Period of Record General Climate Summary, Western Regional Climate Center (July 20, 2011)

2. Building Description



Figure 16 UCM Library Office Wing

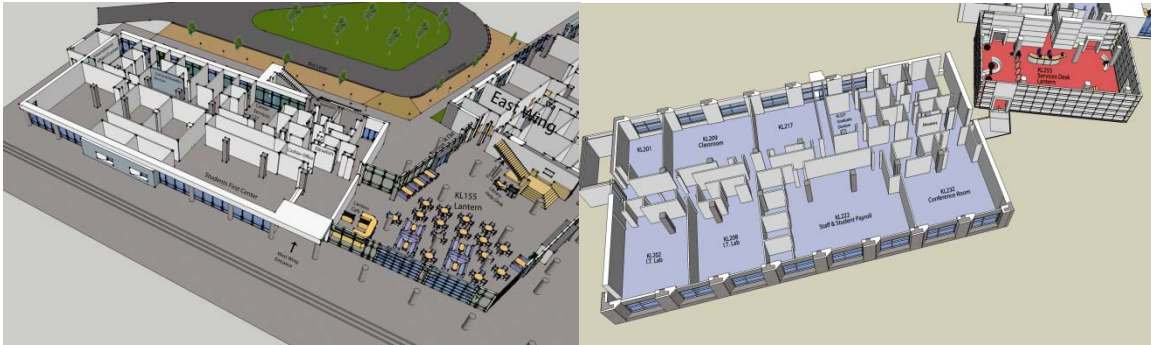

Figure 17 UCM Library Office Wing Building Plan Details (1)

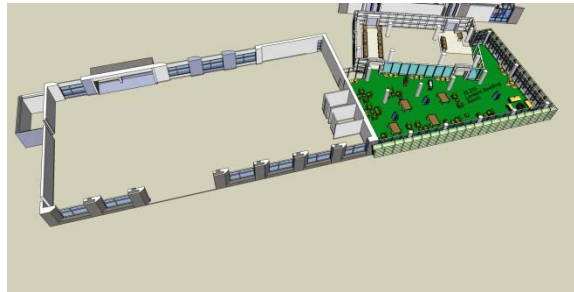

Figure 18 UCM Library Office Wing Building Plan Details (2)

Table 9 UCM Library Office Wing Building Specifications

Category	Item name	Descriptions
Building information	Name	UC Merced Library
	Location	Merced, CA
	Year of construction	2005
	Climate zone	ASHRAE Climate zone 3B
	Type	Office and Library
	number of floor	4 floors (3 for office wing)
	Floor area (m2)	16,000 m ² (7,000 m ² for office)
	Conditioned area (m2)	16,000 m ² (7,000 m ² for office)
	Operation hours	M-F 7:00am - 6:00pm (for office) 94.5 hours per week (for library)
	Max. Occupancy	seating capacity of 1100 + 9 librarians, 14 staff, 45 student assistants (68 staff)
Building Envelope	Exterior wall assembly	Cast concrete
	Roof assembly	Cast concrete
	WWR	20% (Need to check)
	Window	DL clear (Need to check)
	Shading devices	Interior blinds
Lighting System	Interior general lighting	T-8
	Interior task lighting	Fluorescent tube
	Exterior lighting	None
	Control system	ALC
	Operation hours	M-F 7:00am - 6:00pm (for office)
	Lighting Power	0.4 W/ft ² for actual usage average
HVAC	Cooling system	Campus District
	Heating system	Campus District
	Air system	AHU + VAV
	Room set-point	68F – 76F
	Zone	N/A
	Control system	Carrier ALC
	Operation hours	M-F 7:00am - 6:00pm (for office)
Internal Equipment & others	Plug load equipment	Office equipment
	Plug load power	N/A
	Transportation systems	2 elevators shared by office and library
	DHW	District heating and HX
	Energy generation	Campus site PV generation
Control & Monitoring	EMS	Carrier ALC
	Energy Monitoring system	LBNL EPP (Energy Performance Platform)

3. Building Energy Monitoring System

Monitoring System Diagram

The following figure illustrates the structure of power use monitoring based on end uses. The main electricity categories are shown at the top of the diagram: at the system level. Individual equipment is listed below: at the equipment level.

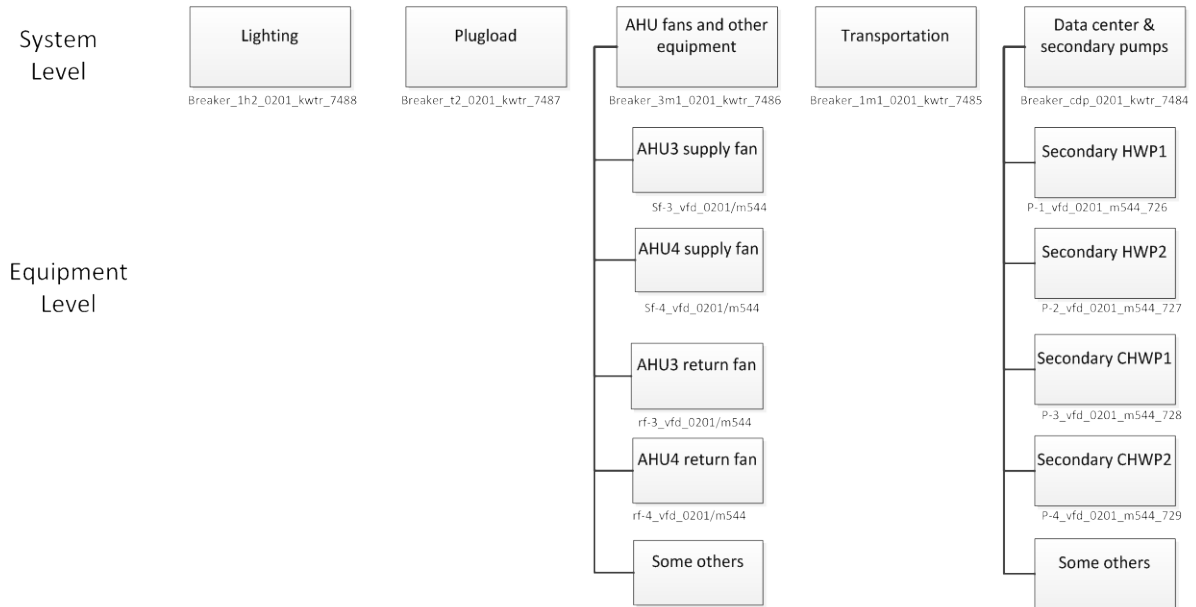

Figure 19 UCM Library Office Wing Monitoring Structure

Monitoring Points Summary

Since the library building is connected with UCM campus district heating and cooling system, the central plant's performance need to be monitored. Then, we can calculate the amount of plant equipment energy use for the library building and its office wing. The points of plants are selected based on plant equipment of chillers, HW boilers, steam boilers, CHW and CW pumps, cooling towers, HW pumps, and their energy performance is measured either in [kWh/interval] for electricity consumption or [btu/hr] for natural gas. And for CHW, HW loops, the SWT, RWT and supply flow rate is monitored.

Table 10 UCM Library Office Wing Monitoring Points Summary

Energy Monitoring	Points	Energy Monitoring point num	Condition Monitoring point num	Comments
Lighting	Main lighting branch	1		
Plug load	Main plug load branch	1		
Transportation	Main elevator branch	1		Shared with library wing
Equipment	Main AHU and equipments panel	1		
	Supply air loop and fan	2		
	Return air loop and fan	2		
Pumping and DC	Secondary pumps and data center	1		
HVAC water loop	Secondary CHW pumps	2		Shared with library wing
	Secondary HW pumps	2		Shared with library wing
Condition Monitoring				
Indoor condition	RMT, VAV flow, damper etc. conditions		7	
Outdoor condition	OAT, OARH		2	
AHU	AHU SAT		2	
	AHU supply air flow rate		2	
	AHU damper position		2	
Building CHW			3	
Building HW			3	
Building DHW			3	
Total points		19	18	37

Table 11 Central Plant Monitoring Points Summary

	Points	Energy Monitoring point num	Condition Monitoring point num	Comments
HVAC plant loop	CHW temperature and flow rate		5	
	HW temperature and flow rate		3	
	Boilers	3		
	Steam boilers	2		
	HW pumps	2		
	CHW storage tank	3		
	Central plant chillers	3		
	Central plant cooling towers	5		
	CW Pumps	3		
	CHW Pumps	5		
Total points		26	8	34

Monitoring Points List

The building performance monitoring points are listed in Table 12 and Table 13. The tables document each monitoring point’s name, description, monitoring point type, data unit, CSV file name and the level of the monitoring. The monitoring data will be sent in CSV format as defined in Table 12 and Table 13. The monitoring interval is 15mins.

Table 12 UCM library office wing monitoring point list

Point ID	Point name	Point Description	Point Type	Unit	File name	Level	Comments
1	breaker_1h2_0201_kwtr_7488	Office wing lighting branch	Electricity	KW	library.csv	System	
2	breaker_3m1_0201_kwtr_7486	AHU fans and other equipments	Electricity	KW	library.csv	System	
3	breaker_t2_0201_kwtr_7487	Office wing plug load	Electricity	KW	library.csv	System	
4	breaker_1m1_0201_kwtr_7485	building's elevator panel	Electricity	KW	library.csv	System	Shared with library and office wing
5	breaker_cdp_0201_kwtr_7484	the secondary pumps and data center	Electricity	KW	library.csv	System	Shared with library and office wing
6	p-1_vfd_0201_m544_726	secondary HWP1	Electricity	KW	library.csv	Equipment	sub-category and included in point ID #5
7	p-2_vfd_0201_m544_727	secondary HWP2	Electricity	KW	library.csv	Equipment	sub-category and included in point ID #5

8	p-3_vfd_0201_m544_728	secondary CHWP1	Electricity	KW	library.csv	Equipment	sub-category and included in point ID #5
9	p-4_vfd_0201_m544_729	secondary CHWP2	Electricity	KW	library.csv	Equipment	sub-category and included in point ID #5
10	sf-3_vfd_0201/m544	AHU3 supply fan VFD	Electricity	KW	library.csv	Equipment	sub-category and included in point ID #2
11	sf-4_vfd_0201/m544	AHU4 supply fan VFD	Electricity	KW	library.csv	Equipment	sub-category and included in point ID #2
12	rf-3_vfd_0201/m544	AHU3 return fan VFD	Electricity	KW	library.csv	Equipment	sub-category and included in point ID #2
13	rf-4_vfd_0201/m544	AHU4 return fan VFD	Electricity	KW	library.csv	Equipment	sub-category and included in point ID #2
14	vav-216_0201/m117	Office wing room 216 zone temp	Indoor Temperature	F	library.csv	Equipment	
15	vav-221_0201/m117	Office wing room 221 zone temp	Indoor Temperature	F	library.csv	Equipment	
16	ahu-3_0201/sa_temp	AHU3 supply air temperature	AHU SAT	F	library.csv	Equipment	
17	ahu-4_0201/sa_temp	AHU4 supply air temperature	AHU SAT	F	library.csv	Equipment	
18	ahu-3_0201/m125	AHU3 supply air flow rate	AHU flow rate	CFM	library.csv	Equipment	
19	ahu-4_0201/q640	AHU4 supply air flow rate	AHU flow rate	CFM	library.csv	Equipment	
20	ahu-3_0201/oa_dmpr	AHU3 OA damper position	AHU OA damper	--	library.csv	Equipment	
21	ahu-4_0201/oa_dmpr	AHU4 OA damper position	AHU OA damper	--	library.csv	Equipment	
22	oa_conditions_0201/oa_temperature	OA temperature	OAT	F	library.csv	Equipment	
23	oa_conditions_1_oa_humidity	OA RH	OARH	%	library.csv	Equipment	this is in "other" building in UCM measurement system
24	chw_bridge_0201/bldg_chws	chilled water supply temperature	CHW SWT	F	library.csv	Equipment	
25	chw_bridge_0201/bldg_chwr	chilled water return temperature	CHW RWT	F	library.csv	Equipment	
26	chw_bridge_0201/chw_flow	chilled water flow rate	CHW Flow rate	GPM	library.csv	Equipment	
27	hw_bridge_0201/pri_m_hws	heating supply water temperature	HW SWT	F	library.csv	Equipment	
28	hw_bridge_0201/bldg_hwr	heating return water temperature	HW RWT	F	library.csv	Equipment	
29	hw_bridge_0201/hw_flow	heating water flow rate	HW Flow rate	GPM	library.csv	Equipment	

				M	v	nt	
30	domestic_hot_water_0201/dhw_supply_temp	DHW supply water temperature	DHW SWT	F	libra ry.csv	Equi pme nt	
31	domestic_hot_water_0201/dhw_return_tem	DHW return water temperature	DHW RWT	F	libra ry.csv	Equi pme nt	
32	domestic_hot_water_0201/hpulse_meter	DHW flow rate	DHW Flow rate	G P M	libra ry.csv	Equi pme nt	
33	vav-302_0201/air_flow/flow_input	room 302 VAV flow rate	Air flow rate	C F M		Equi pme nt	
34	vav-302_0201/air_flow/flow_setpoint	room 302 VAV flow rate setpoint	Air flow rate	C F M		Equi pme nt	
35	vav-302_0201/da_temp	room 302 VAV discharge air temperature	Tempeart ure	F		Equi pme nt	after reheat
36	vav-302_0201/hw_valve	room 302 VAV reheat valve open position	--	%		Equi pme nt	
37	isolation_area_3w_0201/max_mode_tr	3rd floor occupancy mode	occupanc y mode	--		Equi pme nt	1 = unoccupied, 2 = cool down, 3 = startup, 4 = setback, 5 = warm up, 6 = occupied

Table 13 Central plant monitoring point lists

Poi nt ID	Point name	Point Description	Point Type	Un it	File nam e	Level	Comments
1	chiller_1_0208/m126	chiller1 energy consumption	Electri city	K W	plan t.csv	Equi pme nt	
2	chiller_2_0208/m126	chiller2 energy consumption	Electri city	K W	plan t.csv	Equi pme nt	
3	chiller_3_0208/m126	chiller3 energy consumption	Electri city	K W	plan t.csv	Equi pme nt	
4	p-1_vfd_0208/m544	pump1 energy consumption	Electri city	K W	plan t.csv	Equi pme nt	
5	p-2_vfd_0208/m544	pump2 energy consumption	Electri city	K W	plan t.csv	Equi pme nt	
6	p-3_vfd_0208/m544	pump3 energy consumption	Electri city	K W	plan t.csv	Equi pme nt	
7	p-4_vfd_0208/m544	pump4 energy consumption	Electri city	K W	plan t.csv	Equi pme nt	
8	p-5_vfd_0208/m544	pump5 energy consumption	Electri city	K W	plan t.csv	Equi pme nt	
9	ct-1_vfd_interface_0208/m544	cool tower1 energy consumption	Electri city	K W	plan t.csv	Equi pme nt	
10	ct-2_vfd_interface_0208/m544	cool tower2 energy consumption	Electri city	K W	plan t.csv	Equi pme nt	
11	ct-3_vfd_interface_02	cool tower3 energy consumption	Electri city	K W	plan t.csv	Equi pme	

	08/m544					nt	
12	ct-4_vfd_interface_0208/m544	cool tower4 energy consumption	Electricity	KW	plan t.csv	Equipment	
13	ct-5_vfd_interface_0208/m544	cool tower5 energy consumption	Electricity	KW	plan t.csv	Equipment	
14	chiller_control_0208/cmmn_chws	chilled water system SWT	Temperature	F	plan t.csv	Equipment	
15	chiller_control_0208/cmmn_chwr	chilled water system RWT	Temperature	F	plan t.csv	Equipment	
16	chiller_control_0208/pchws_flw	chilled water system flow rate	Flow rate	GP M	plan t.csv	Equipment	
17	boiler_1_control_0208/m015	boiler1 energy consumption	Natural gas	btu/hr	plan t.csv	Equipment	
18	boiler_2_control_0208/m015	boiler2 energy consumption	Natural gas	btu/hr	plan t.csv	Equipment	
19	boiler_3_control_0208/m015	boiler3 energy consumption	Natural gas	btu/hr	plan t.csv	Equipment	
20	stm_blr_1_0208/m015	steam boiler1 energy consumption	Natural gas	btu/hr	plan t.csv	Equipment	
21	stm_blr_2_0208/m015	steam boiler2 energy consumption	Natural gas	btu/hr	plan t.csv	Equipment	
22	p-9_vfd_0208/m544	heating water pump1	Electricity	KW	plan t.csv	Equipment	
23	p-10_vfd_0208/m544	heating water pump2	Electricity	KW	plan t.csv	Equipment	
24	boiler_manager_0208/hws_flow	heating supply water flow rate	Flow rate	GP M	plan t.csv	Equipment	
25	boiler_manager_0208/cmmn_hws_temp	heating supply water temperature	Temperature	F	plan t.csv	Equipment	
26	boiler_manager_0208/cmmn_hwr_temp	heating supply water temperature	Temperature	F	plan t.csv	Equipment	
27	chiller_control_0208/pchws_flw_tnk	Chilled water flow rate to tank	Flow rate	GP M		System	see picture
28	chiller_control_0208/pchwr_temp	Chilled water primary return water temp	Temperature	F		System	see picture,
29	all_bridge_valve_positions/m390	All buildings CHW flow rate sum	Flow rate	GP M		System	see picture, in "other" building type, CHW flow rate to all campus buildings
30	tank_sensors_0208/temp_56/	tank chilled water intake temp (charging)	Temperature	F		Equipment	see picture, also is tank discharge CHW temp, when charging, this is also CHW primary SWT
31	tank_sensors_0208/m872	tank chilled water level sensor	Percentage	%		Equipment	see picture
32	cws_manager_0208/p1_status	condenser water pump 1 running status	status	---		Equipment	0 for time to turn off, 1 for time to turn on
33	cws_manager_0208/p2_status	condenser water pump 2 running	status	---		Equipment	0 for time to turn off, 1 for time to turn on

		status				nt	
34	cws_manager_020 8/p3_status	condenser water pump 3 running status	status	---		Equipme nt	0 for time to turn off, 1 for time to turn on

Lawrence Berkeley National Laboratory - Building 90

1. Location and Climate

Location

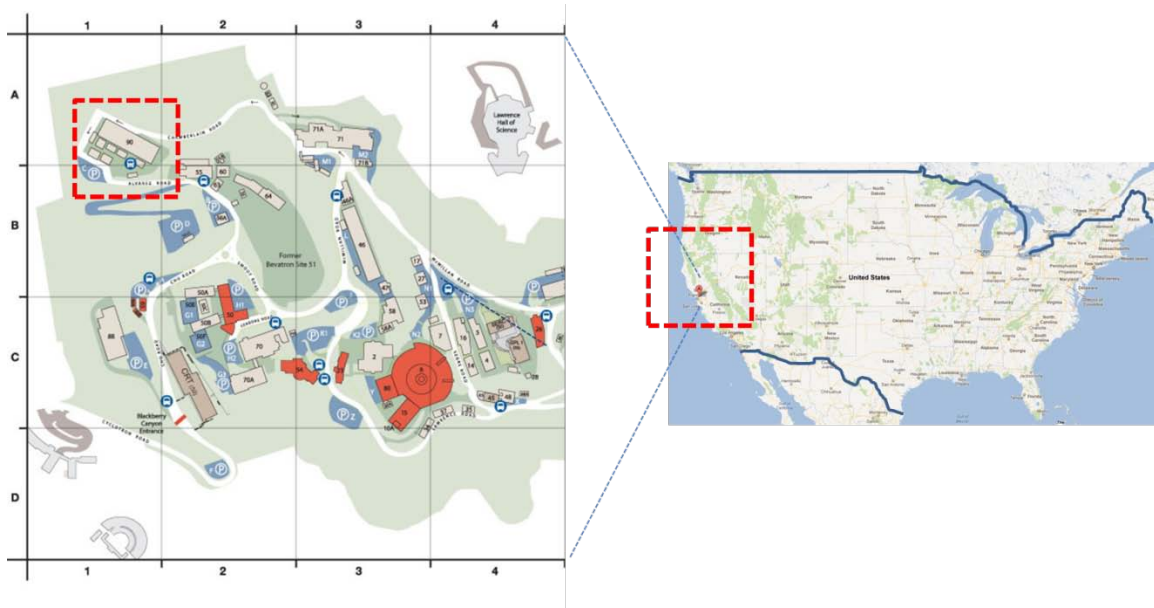

Figure 20 LBNL Building 90 Location

Climate

Table 14 Climate Data (Berkeley, CA)

Month	Unit	Jan	Feb	Mar	Apr	May	Jun	Jul	Aug	Sep	Oct	Nov	Dec	Year
Average High	°C	14	15	16	18	19	21	21	21	22	21	17	14	18
	°F	56	59	61	64	67	70	70	71	72	70	62	57	65
Average Low	°C	6.4	7.8	8.6	9.2	11	12	13	13	13	12	8.8	6.5	10
	°F	44	46	47	49	51	54	55	56	56	54	48	44	50
Precipitation	mm	130	121	104	41	16	3.6	1.8	2.5	9.1	35	92	90	645
	inches	5.1	4.8	4.1	1.6	0.6	0.1	0.1	0.1	0.4	1.4	3.6	3.5	25

Source: National Oceanic and Atmospheric Administration (NOAA) (1971-2000)

2. Building Description



Figure 21 LBNL Building 90

Table 15 LBNL Building 90 Building Specifications

Category	Item name	Descriptions
Building information	Name	Building 90
	Location	Berkeley, CA
	Year of construction	1960
	Climate zone	ASHRAE Climate Zone 3C
	Type	Office
	number of floor	1 partial basement, 4 above-grade floors
	Floor area (m2)	8,316 m ² (89,513 ft ²)
	Conditioned area (m2)	N/A
	Operation hours	M-F 7:00am - 6:00pm (average)
	Max. Occupancy	400 people
Building Envelope	Exterior wall assembly	Transite, metal surface
	Roof assembly	Transite
	WWR	About 20%
	Window	Low-e coated / clear single pane window
	Shading devices	Interior blinds
Lighting System	Interior general lighting	T-8
	Interior task lighting	Fluorescent tube
	Exterior lighting	N/A

	Control system	Occupancy sensors in some spaces
	Operation hours	N/A
	Lighting Power	5-5.6 W/m ² (Originally 20W/m ² , before retrofits)
HVAC	Cooling system	DX coils, large RTUs with airside economizer
	Heating system	Gas Boiler
	Air system	VAV
	Room set-point	Average of 72F occupied and 62F non occupied
	Zone	N/A
	Control system	Johnson Controls - Metasys: GPL & GX9100
	Operation hours	M-F 7:00am - 6:00pm (average)
Internal Equipment & others	Plug load equipment	Office equipment
	Plug load power	14.3 W/m ²
	Transportation systems	1 elevator
	DHW	Gas water heater
	Energy generation	PVs (not used any more)
Control & Monitoring	EMS	Johnson Controls - Metasys: GPL & GX9100
	Energy Monitoring system	EIS - Pulse

3. Building Monitoring System

Figure 22 illustrates the structure of power use monitoring based on end uses. The main electricity categories are shown at the top of the diagram: at the system level. Individual equipment is listed below: at the equipment level. Each monitoring point name is indicated under the corresponding monitoring system or equipment. Lists of points for controlling and monitoring system performance are shown in Table 16 to Table 21.

Monitoring System Diagram

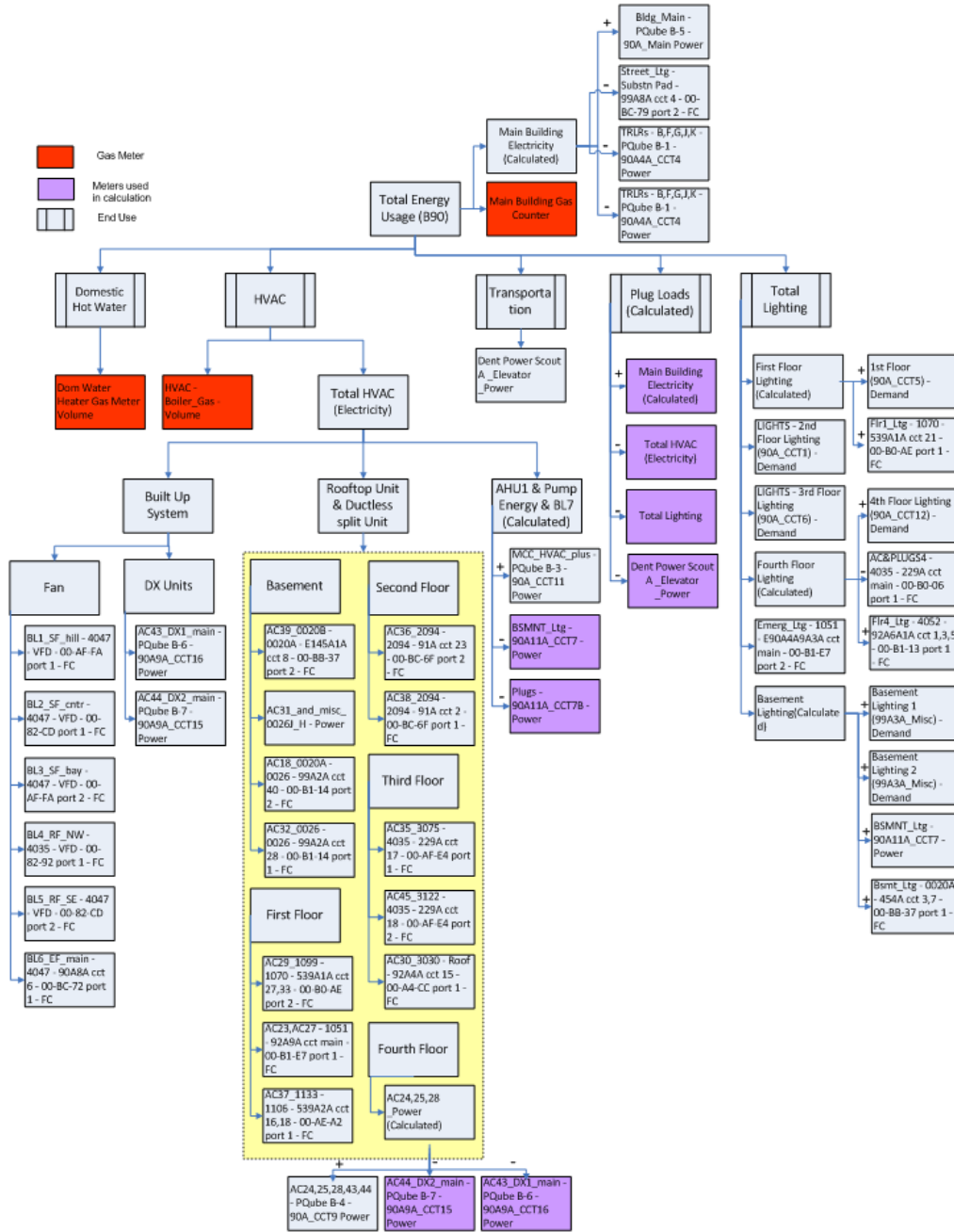

Figure 22 LBNL Building 90 Monitoring Structure

Monitoring Points Summary

Table 16 LBNL Building 90 Monitoring Points Summary

	Item monitored	Details	Number of monitoring points	
Electricity and gas	Lighting	Lighting	8	
	Plug load	Plug load	1	
	Transportation	Elevator	1	
	HVAC	AHU fan (blower)		4
		RTU compressor		4
		heating/hot water pumps		2
	Split AC	room split AC	16	
	Natural Gas	total boiler usage, and DHW	2	
	Water usage		1	
Total points		40		
Conditions	Indoor condition	Room Temperature	10	
	Outdoor condition	OAT	1	
	AHU	AHU SAT	4	
		AHU RAT	4	
		AHU supply air flow rate	4	
		AHU OA damper position	4	
		Fan Speed	4	
	Building HW	SWT, RWT, SWF	3	
	Controls and operation	Occ_schedule	5	
		SAT	5	
		RMAT	5	
		Split AC schedule	0	
	Total points		49	

Monitoring Points List

Table 17 Building 90 energy monitoring points by end use - HVAC

# of AC per point	# of the AC	Floor(s)	Name of the point	Type of point	Calculation
AHU, Pumps and exhaust fan	AHU1, Pumps, BL7	Basement	HVAC - AHU1	Calculated	= <u>MCC HVAC plus - PQube B-3 - 90A CCT11 Power - BSMNT Ltg - 90A11A CCT7 - Power - Plugs - 90A11A CCT7B - Power</u>
1 AC	18	Basement	HVAC - AC18_0020A - 0026 - 99A2A cct 40 - 00-B1-14 port 2 - FC	Calculated	= $32.975 \times Z_{Raw} - HVAC - AC18_0020A - 0026 - 99A2A cct 40 - 00-B1-14 port 2 - FC - 9.0075 kW$
2 AC	23, 27	1st	HVAC - AC23,AC27 - 1051 - 92A9A cct main -	Calculated	= $32.975 \times Z_{Raw} - HVAC - AC23,AC27 - 1051 - 92A9A cct$

			00-B1-E7 port 1 - FC		main - 00-B1-E7 port 1 - FC - 9.0075 kW
1 AC	31	Basement	HVAC - AC31_and_misc_H - Power	Calculated	= 32.975 × Z Raw - HVAC - AC31 and misc H - Power - 9.0075 kW
1 AC	32	Basement	HVAC - AC32_0026 - 0026 - 99A2A cct 28 - 00-B1-14 port 1 - FC	Calculated	= 32.975 × Z Raw - HVAC - AC32 0026 - 0026 - 99A2A cct 28 - 00-B1-14 port 1 - FC - 9.0075 kW
1 AC	35	3rd	HVAC - AC35_3075 - 4035 - 229A cct 17 - 00-AF-E4 port 1 - FC	Calculated	= 32.975 × Z Raw - HVAC - AC35 3075 - 4035 - 229A cct 17 - 00-AF-E4 port 1 - FC - 9.0075 kW
1 AC	36	2nd	HVAC - AC36_2094 - 2094 - 91A cct 23 - 00-BC-6F port 2 - FC - Power	Out of order	
1 AC	38	2nd	HVAC - AC38_2094 - 2094 - 91A cct 2 - 00-BC-6F port 1 - FC	Calculated	= 32.975 × Z Raw - HVAC - AC38 2094 - 2094 - 91A cct 2 - 00-BC-6F port 1 - FC - 9.0075 kW
1 AC	29	1st	HVAC - AC29_1099 - 1070 - 539A1A cct 27,33 - 00-B0-AE port 2 - FC	Calculated	= 32.975 × Z Raw - HVAC - AC29 1099 - 1070 - 539A1A cct 27,33 - 00-B0-AE port 2 - FC - 9.0075 kW
1 AC	37	1st	HVAC - AC37_1133 - 1106 - 539A2A cct 16,18 - 00-AE-A2 port 1 - FC	Calculated	= 32.975 × Z Raw - HVAC - AC37 1133 - 1106 - 539A2A cct 16,18 - 00-AE-A2 port 1 - FC - 9.0075 kW
1 AC	45	3rd	HVAC - AC45_3122 - 4035 - 229A cct 18 - 00-AF-E4 port 2 - FC	Calculated	= 32.975 × Z Raw - HVAC - AC45 3122 - 4035 - 229A cct 18 - 00-AF-E4 port 2 - FC - 9.0075 kW
1 AC	30	3rd	HVAC - AC30_3030 - Roof - 92A4A cct 15 - 00-A4-CC port 1 - FC	Calculated	= 32.975 × Z Raw - HVAC - AC30 3030 - Roof - 92A4A cct 15 - 00-A4-CC port 1 - FC - 9.0075 kW
1 AC	39	Basement	HVAC - AC39_0020B - 0020A - E145A1A cct 8 - 00-BB-37 port 2 - FC	Calculated	= 32.975 × Z Raw - HVAC - AC39 0020B - 0020A - E145A1A cct 8 - 00-BB-37 port 2 - FC - 9.0075 kW
3 AC	24, 25 & 28	4th Floor	CERC 4th Floor AC (24, 25 & 28)	Calculated	= AC24,25,28,43,44 - PQube B-4 - 90A CCT9 Power - AC43 DX1 main - PQube B-6 -

					<u>90A9A CCT16 Power - AC44 DX2 main - PQube B-7 - 90A9A CCT15 Power</u>
DX	43		AC43_DX1_main - PQube B-6 - 90A9A_CCT16 Power	Monitored	
DX	44		AC44_DX2_main - PQube B-7 - 90A9A_CCT15 Power	Monitored	
Supply Fan	BL1		HVAC - BL1_SF_hill - 4047 - VFD - 00-AF-FA port 1 - FC	Calculated	= 17.55 × <u>Z Raw - HVAC - BL1 SF hill - 4047 - VFD - 00-AF-FA port 1 - FC</u>
Supply Fan	BL2		HVAC - BL2_SF_cntr - 4047 - VFD - 00-82-CD port 1 - FC	Calculated	= 17.55 × <u>Z Raw - HVAC - BL2 SF cntr - 4047 - VFD - 00-82-CD port 1 - FC</u>
Supply Fan	BL3		HVAC - BL3_SF_bay - 4047 - VFD - 00-AF-FA port 2 - FC	Calculated	= 17.55 × <u>Z Raw - HVAC - BL3 SF bay - 4047 - VFD - 00-AF-FA port 2 - FC</u>
Return Fan	BL4		HVAC - BL4_RF_NW - 4035 - VFD - 00-82-92 port 1 - FC	Calculated	= 17.55 × <u>Z Raw - HVAC - BL4 RF NW - 4035 - VFD - 00-82-92 port 1 - FC</u>
Return Fan	BL5		HVAC - BL5_RF_SE - 4047 - VFD - 00-82-CD port 2 - FC	Calculated	= 5.5575 × <u>Z Raw - HVAC - BL5 RF SE - 4047 - VFD - 00-82-CD port 2 - FC</u>
Exhaust Fan	BL6		HVAC - BL6_EF_main - 4047 - 90A8A cct 6 - 00-BC-72 port 1 - FC	Calculated	= 76.09 × <u>Z Raw - HVAC - BL6 EF main - 4047 - 90A8A cct 6 - 00-BC-72 port 1 - FC - 21.6856</u>

Table 18 Building 90 energy monitoring points by end use - Lighting

Name of the point	Details	Type of point	Calculation
Sum of Basement Lighting	Basement	Calculated	= (<u>LIGHTS - Basement Lighting 1 (99A3A Misc)</u>) + (<u>Demand+LIGHTS - Basement Lighting 2 (99A3A Misc)</u>) + (<u>Demand+BSMNT Ltg - 90A11A CCT7 - Power</u>) + (<u>Lighting - Bsmt Ltg - 0020A - 454A cct 3,7 - 00-BB-37 port 1 - FC</u>)
LIGHTS - 1st Floor (90A_CCT5) - Demand	1st	Monitored	

Lighting - Flr1_Ltg - 1070 - 539A1A cct 21 - 00-B0-AE port 1 - FC	1st	Calculated	= 32.975 × Z Raw - Lighting - Flr1 Ltg - 1070 - 539A1A cct 21 - 00-B0-AE port 1 - FC - 9.0075 kW
LIGHTS - 2nd Floor Lighting (90A_CCT1) - Demand	2nd	Monitored	
LIGHTS - 3rd Floor Lighting (90A_CCT6) - Demand	3rd	Monitored	
*Sum of Fourth Floor Lighting	4th	Calculated	= LIGHTS - 4th Floor Lighting (90A CCT12) - Demand - 1.111 × Mixed - AC&PLUGS4 - 4035 - 229A cct main - 00-B0-06 port 1 - FC + Lighting - Flr4 Ltg - 4052 - 92A6A1A cct 1,3,5 - 00-B1-13 port 1 - FC
Lighting - Emerg_Ltg - 1051 - E90A4A9A3A cct main - 00-B1-E7 port 2 - FC	Emergency	Calculated	= 76.09 × Z Raw - Lighting - Emerg Ltg - 1051 - E90A4A9A3A cct main - 00-B1-E7 port 2 - FC - 20.785 kW
Lighting - Street_Ltg - Substn Pad - 99A8A cct 4 - 00-BC-79 port 2 - FC	Street	Calculated	= 32.975 × Z Raw - Lighting - Street Ltg - Substn Pad - 99A8A cct 4 - 00-BC-79 port 2 - FC - 9.0075 kW

Table 19 Building 90 energy monitoring points by end use - Transportation

Element monitored	Name of the point	Type of point	Calculation
Elevator	Dent Power Scout A - Elevator-Power	Monitored	

Table 20 Building 90 energy monitoring points by end use - Plug Loads

Element monitored	Name of the point	Type of point	Calculation
Plugs	*Miscellaneous - Temp Fix	Calculated	'= (B90 Main Bldg Electricity) - (Lighting Total) - *B90 HVAC Total - (Dent PowerScout A - Elevator) + (Lighting - Flr1 Ltg - 1070 - 539A1A cct 21 - 00-B0-AE port 1 - FC) + (Lighting - Bsmt Ltg - 0020A - 454A cct 3,7 - 00-BB-37 port 1 - FC) - 0.48

Table 21 Building 90 energy monitoring points by end use - Natural Gas

Name of the point	Type of point	Calculation
*Dom Water Heater Gas Meter Average Power	Calculated	Converted from Dom Water Heater Gas Meter Counter
HVAC - Boiler_Gas - Average Power	Calculated	Converted from Internal I/O Gas Pulse 3
Main Building Gas Counter	Monitored	= $32.975 \times \underline{\mathbf{Z\ Raw - HVAC - AC23,AC27 - 1051 - 92A9A\ cct\ main - 00-B1-E7\ port\ 1 - FC}}$ -9.0075 kW

Conversion details:

Internal I/O Gas Pulse 3 [From counts to ft3: 1 ft3/count] → *HVAC - Boiler_Gas – Volume [From ft3 to Therm: 0.0103 Therm/ft3] → HVAC - Boiler_Gas – Energy [From Therm to kW (update frequency of 15mns)] → HVAC - Boiler_Gas - Average Power

Dom Water Heater Gas Meter Counter [From counts to ft3: 1 ft3/count] *Dom Water Heater Gas Meter Volume [From ft3 to Therm: 0.0103 Therm/ft3] → *Dom Water Heater Gas Meter Energy [From Therm to kW (update frequency of 15mns)] → *Dom Water Heater Gas Meter Average Power

The monitoring data will be recorded in CVS format. The monitoring interval is 15 minutes.

Table 22 Building 90 condition monitoring points list

Name of the point	Description	Type of point	Unit
90_BL1 - 50_OAT	Outdoor Air Temperature	Temperature	Fahrenheit
90_BL1 - AVG_TEMP	Average Zone Temperature	Temperature	Fahrenheit
90_BL1 - HI_TEMP	High and Low Temperature	Temperature	Fahrenheit
90_BL1 - HWV	Hot Water Temperature	Temperature	Fahrenheit
90_BL1 - LO_TEMP	High and Low Temperature	Temperature	Fahrenheit
90_BL1 - MAT	Mixed Air Temperature	Temperature	Fahrenheit
90_BL1 - RAT	Return Air Temperature	Temperature	Fahrenheit
90_BL1 - SAT	Supply Air Temperature	Temperature	Fahrenheit
90_BL1 - SS	Fan Control	State	On/Off
90_BL2 - AVG_TEMP	Average Zone Temperature	Temperature	Fahrenheit
90_BL2 - HI_TEMP	High and Low Temperature	Temperature	Fahrenheit
90_BL2 - LO_TEMP	High and Low Temperature	Temperature	Fahrenheit
90_BL2 - MAT	Mixed Air Temperature	Temperature	Fahrenheit
90_BL2 - OAT	Outdoor Air Temperature	Temperature	Fahrenheit
90_BL2 - SAT	Supply Air Temperature	Temperature	Fahrenheit
90_BL2 - SS	Fan Control	State	On/Off
90_BL3 - AVG_TEMP	Average Zone Temperature	Temperature	Fahrenheit
90_BL3 - HI_TEMP	High and Low Temperature	Temperature	Fahrenheit
90_BL3 - LO_TEMP	High and Low Temperature	Temperature	Fahrenheit
90_BL3 - MAT	Mixed Air Temperature	Temperature	Fahrenheit
90_BL3 - OAT	Outdoor Air Temperature	Temperature	Fahrenheit
90_BL3 - SAT	Supply Air Temperature	Temperature	Fahrenheit
90_BL3 - SS	Fan Control	State	On/Off
90_Z301 - HHW_VLV	Hot Water Temperature	Percentage of Total	Percentage
90_Z301 - SAT	Supply Air Temperature	Temperature	Fahrenheit
90_Z301 - ZAT_1	Zone Air Temperature	Temperature	Fahrenheit
90_Z301 - ZAT_2	Zone Air Temperature	Temperature	Fahrenheit
90_Z303 - HHW_VLV	Hot Water Temperature	Percentage of Total	Percentage
90_Z303 - OCC-SP	Set Point	Temperature	Fahrenheit
90_Z303 - SAT	Supply Air Temperature	Temperature	Fahrenheit
90_Z303 - ZAT_1	Zone Air Temperature	Temperature	Fahrenheit
90_Z303 - ZAT_2	Zone Air Temperature	Temperature	Fahrenheit
90_Z303 - ZAT_AVG	Zone Air Temperature	Temperature	Fahrenheit
90_Z305 - HHW_VLV	Hot Water Temperature	Percentage of Total	Percentage
90_Z305 - OCC-SP	Set Point	Temperature	Fahrenheit
90_Z305 - SAT	Supply Air Temperature	Temperature	Fahrenheit
90_Z305 - ZAT_1	Zone Air Temperature	Temperature	Fahrenheit
90_Z305 - ZAT_2	Zone Air Temperature	Temperature	Fahrenheit
90_Z401 - SS_CMP	Compressor Control	State	On/Off
90_Z401 - SS_SF	Fan Control	State	On/Off
90_Z401 - ZAT_1	Zone Air Temperature	Temperature	Fahrenheit
90_Z401 - ZAT_2	Zone Air Temperature	Temperature	Fahrenheit
90_AC24 - AVG_TMP	Average Zone Temperature	Temperature	Fahrenheit
90_AC24 - MAT	Mixed Air Temperature	Temperature	Fahrenheit
90_AC24 - SCH_OCC	Occupancy Schedule	State	On/Off
90_AC24 - SS_CMP	Compressor Control	State	On/Off
90_AC24 - SS_SF	Fan Control	State	On/Off
90_AC24 - ZAT_1	Zone Air Temperature	Temperature	Fahrenheit
90_AC24 - ZAT_2	Zone Air Temperature	Temperature	Fahrenheit

California State Teachers' Retirement System (CalSTRS)

1. Location and Climate

Location

CalSTRS headquarters reflects our commitment to California's public educators. The headquarters building, located in West Sacramento, aligns business and technology changes to improve member services.

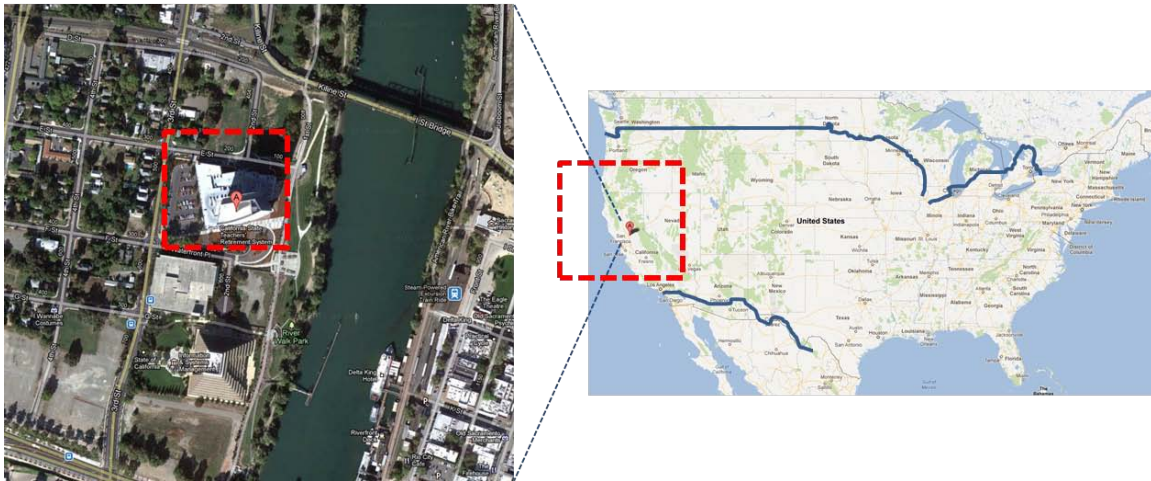

Figure 23 CalSTRS Building

Climate

Table 23 Climate Data (Sacramento, CA)

Month	Unit	Jan	Feb	Mar	Apr	May	Jun	Jul	Aug	Sep	Oct	Nov	Dec	Year
Average High	°C	12	16	19	22	27	31	34	33	31	26	18	12	23
	°F	54	61	66	72	80	87	92	92	88	78	64	54	74
Average Low	°C	3.9	5.4	6.8	8.1	11	13	15	15	13	10	6.1	3.6	9.2
	°F	39	42	44	47	51	56	59	58	56	51	43	39	49
Precipitation	mm	93	88	70	29	17	5.3	0.0	1.3	7.4	24	53	83	470
	inches	3.7	3.5	2.8	1.2	0.7	0.2	0.0	0.1	0.3	0.9	2.1	3.3	19

Source: Sacramento Executive Airport, NOAA, The Weather Channel (1981-2010)

2. Building Description

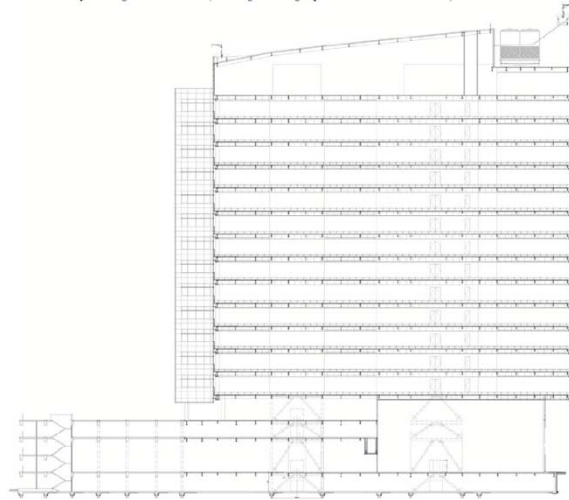

Figure 24 CalSTRS Building

Table 24 CalSTRS Building Specifications

Category	Item name	Descriptions
Building information	Name	CalSTRS Headquarters
	Location	West Sacramento, CA
	Year of construction	2009
	Climate zone	ASHRAE Climate Zone 3B
	Type	Office (13 floors), Podiums (5 floors)
	number of floor	18 Floors
	Floor area (m2)	34,374 m ² (370,000 ft ²)
	Conditioned area (m2)	N/A
	Operation hours	M-F 6:00am - 6:00pm (a few floor/rooms are operated from 5:00am in workdays)
Max. Occupancy	1150 people (when full occupied)	
Building Envelope	Exterior wall assembly	Facade
	Roof assembly	cast concrete
	WWR	100% facade
	Window	Low-e, Low-SHGC, High-VT
	Shading devices	Interior blinds
Lighting System	Interior general lighting	T-5
	Interior task lighting	occupant-specific

	Exterior lighting	HID
	Control system	Dimmable control (Lutron)
	operation hours	Exterior lighting off at 6 pm, manually on
	Lighting Power	N/A
HVAC	cooling system	WSHP (the lower five floors), 2 York Chillers + variable speed compressors
	heating system	WSHP (the lower five floors)
	Air system	UFAD + VFD controlled fans
	Room set-point	71F~78F
	Zone	N/A
	Control system	Frank M. Booth
	operation hours	M-F 6:00am - 6:00pm (a few floor/rooms are operated from 5:00am in workdays)
Internal Equipment & others	Plug load equipment	N/A
	Plug load energy	N/A
	Transportation systems	A few elevators, 1 freight elevator
	DHW	Natural gas boiler (gym shower, restrooms), Electrical heater for drinking water
	Energy generation	None
Control & Monitoring	EMS	Eaton system
	Energy Monitoring system	Eaton system

The building is a thirteen-story tower on the Riverwalk in West Sacramento, California (Figure 1). It was completed in 2009 and includes 490,000 square feet of office space (Figure 2), two floors of public space and both covered and uncovered parking. The building has only one tenant and is owner-occupied by CalSTRS, which sets it apart from the more common notion of the multi-tenanted office building. The building was awarded a LEED Gold certification and includes a number of features aimed at reducing energy use while promoting occupant comfort, including underfloor air distribution (UFAD) with adjustable diffusers, daylight optimization and heat pumps. Occupants have access to a number of comfort controls including task lights, airflow diffusers and -- more communally -- window blinds. Occupants may bring in personal fans if necessary, but personal heaters are prohibited. In 2010, the building achieved an ENERGY STAR rating of 95 and is currently seeking LEED-EBOM (Existing Building Operations and Maintenance) certification.

3. Building Energy Monitoring System

Monitoring System Diagram

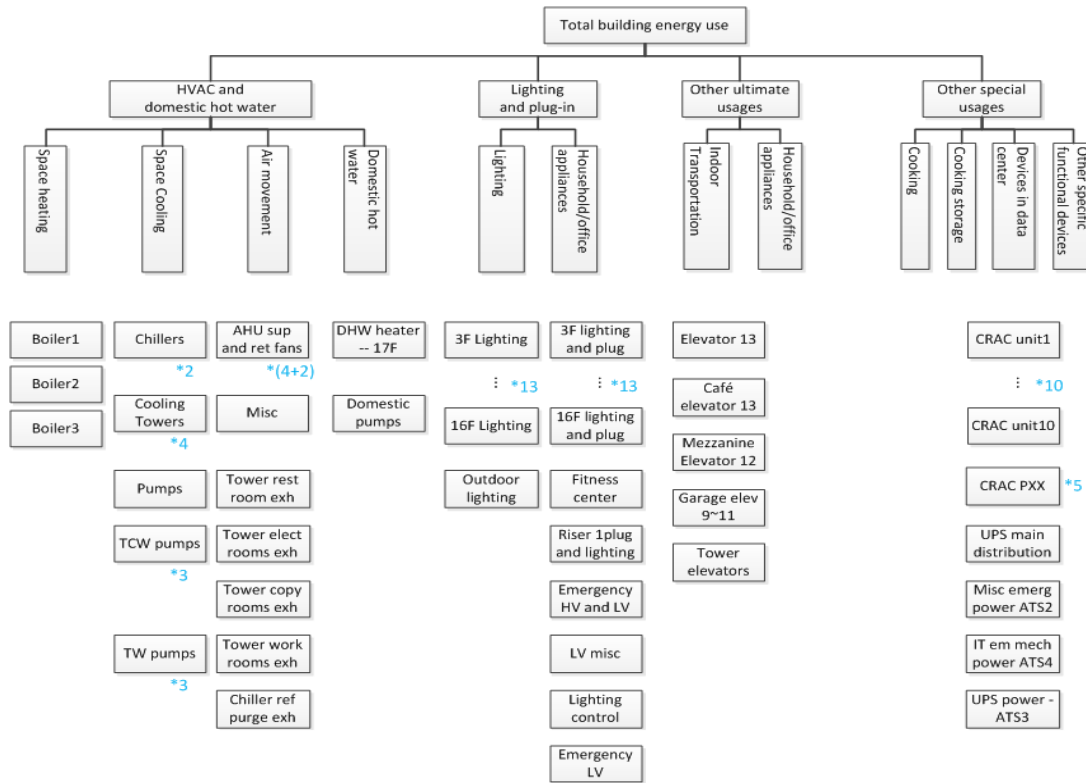

Figure 25 CalSTRS Building Monitoring Structure

Monitoring Points List

Table 25 CalSTRS Building Energy Metering Points

Point ID	Point Description	Point Type	Unit	Level
1	Outdoor lighting	Lighting	kW	System
2	3F lighting	Lighting	kW	System
3	4F lighting	Lighting	kW	System
4	5F lighting	Lighting	kW	Equipment
5	6F lighting	Lighting	kW	Equipment
6	7F lighting	Lighting	kW	Equipment
7	8F lighting	Lighting	kW	Equipment
8	9F lighting	Lighting	kW	Equipment
9	10F lighting	Lighting	kW	Equipment
10	11F lighting	Lighting	kW	Equipment
11	12F lighting	Lighting	kW	Equipment
12	14F lighting	Lighting	kW	Equipment
13	15F lighting	Lighting	kW	Equipment
14	16F lighting	Lighting	kW	Equipment
15	3F total	Lighting + Plug	kW	Equipment

16	4F total	Lighting + Plug	kW	Equipment
17	5F total	Lighting + Plug	kW	Equipment
18	6F total	Lighting + Plug	kW	Equipment
19	7F total	Lighting + Plug	kW	Equipment
20	8F total	Lighting + Plug	kW	Equipment
21	9F total	Lighting + Plug	kW	Equipment
22	10F total	Lighting + Plug	kW	Equipment
23	11F total	Lighting + Plug	kW	Equipment
24	12F total	Lighting + Plug	kW	Equipment
25	14F total	Lighting + Plug	kW	Equipment
26	15F total	Lighting + Plug	kW	Equipment
27	16F total	Lighting + Plug	kW	Equipment
28	Fitness Center	Mixed	kW	Equipment
	Riser 1 plug and lighting	Mixed	kW	Equipment
29	Emergency HV and LV	Mixed	kW	Equipment
30	LV misc	Mixed	kW	Equipment
31	Lighting control panel	plug	kW	Equipment
32	Emergency LV	plug	kW	Equipment
33	AHU supply fan1	HVAC	kW	Equipment
34	AHU supply fan2	HVAC	kW	Equipment
35	AHU supply fan3	HVAC	kW	Equipment
36	AHU supply fan4	HVAC	kW	Equipment
37	AHU return fan1	HVAC	kW	Equipment
38	AHU return fan2	HVAC	kW	Equipment
39	Chiller1	HVAC	kW	Equipment
40	Chiller2	HVAC	kW	Equipment
41	Cooling Tower 1A	HVAC	kW	Equipment
42	Cooling Tower 1B	HVAC	kW	Equipment
43	Cooling Tower 1C	HVAC	kW	Equipment
44	Cooling Tower 1D	HVAC	kW	Equipment
45	Pumps (CHWP, CWP, HWP)	HVAC	kW	Equipment
46	Other misc (Exhaust fans, boilers, misc lights)	HVAC	kW	Equipment
47	Tower restroom exhaust	HVAC	kW	Equipment
48	Tower electric rooms exhaust	HVAC	kW	Equipment
49	Tower copy rooms exhaust	HVAC	kW	Equipment
50	Tower work room exhaust	HVAC	kW	Equipment
51	Chiller room refrigeration purge exhaust	HVAC	kW	Equipment
52	Boiler1	HVAC	kW	Equipment
53	Boiler2	HVAC	kW	Equipment
54	Boiler3 & Chiller room FCU	HVAC	kW	Equipment
55	TCW pump1 (primary)	HVAC	kW	Equipment
56	TCW pump2 (primary)	HVAC	kW	Equipment
57	TCW pump3 (primary)	HVAC	kW	Equipment
58	TW pump1 (secondary)	HVAC	kW	Equipment
59	TW pump2 (secondary)	HVAC	kW	Equipment
60	TW pump3 (secondary)	HVAC	kW	Equipment
61	UPS power - ATS3	Data center	kW	Equipment
62	Misc emergency power - ATS2	Data center	kW	Equipment
63	IT emergency mech power - ATS4	Data center	kW	Equipment

64	Server room, P5A	Data center	kW	Equipment
65	Server room, P2B	Data center	kW	Equipment
66	Server room, P3B	Data center	kW	Equipment
67	Server room, P4B	Data center	kW	Equipment
68	Server room, P5A	Data center	kW	Equipment
69	UPS main distribution	Data center	kW	Equipment
70	CRAC unit1	Data center	kW	Equipment
71	CRAC unit2	Data center	kW	Equipment
72	CRAC unit3	Data center	kW	Equipment
73	CRAC unit4	Data center	kW	Equipment
74	CRAC unit5	Data center	kW	Equipment
75	CRAC unit6	Data center	kW	Equipment
76	CRAC unit7	Data center	kW	Equipment
77	CRAC unit8	Data center	kW	Equipment
78	CRAC unit9	Data center	kW	Equipment
79	CRAC unit10	Data center	kW	Equipment
84	Elevator 13	Transportation	kW	Equipment
80	Café elevator 13	Transportation	kW	Equipment
81	Mezzanine Elevator 12	Transportation	kW	Equipment
82	Garage elevator 9~11	Transportation	kW	Equipment
83	Tower elevators	Transportation	kW	Equipment
85	Domestic water heater -- 17F	DHW	kW	Equipment
86	Domestic booster pumps	DHW	kW	Equipment

Table 26 CalSTRS Building Conditions Monitoring Point

Point ID	Point Description	Point Type	Unit
1	Room xxx temperature (West side)	Temperature	F
2	Room xxx temperature (East side)	Temperature	F
3	OAT	Temperature	F
4	OARH	Relative Humidity	%
5	AHU SAT East duct	Temperature	F
6	AHU SAT West duct	Temperature	F
7	AHU SAT setpoint	Temperature	F
8	AHU min OA duct flow rate	Flow rate	CFM
9	AHU modulated duct flow rate	Flow rate	CFM
10	OA damper position	Percentage	%
11	Exhaust damper position	Percentage	%
12	AHU supply fan1 speed	Percentage	%
13	AHU supply fan2 speed	Percentage	%
14	AHU supply fan3 speed	Percentage	%
15	AHU supply fan4 speed	Percentage	%
16	AHU return air flow rate (West duct)	Flow rate	CFM
17	AHU return air flow rate (East duct)	Flow rate	CFM
18	AHU return air temperature (West duct)	Temperature	F
19	AHU return air temperature (East duct)	Temperature	F
20	AHU return fan1 speed	Percentage	%
21	AHU return fan2 speed	Percentage	%
22	CHW supply temperature (chiller 1)	Temperature	F

23	CHW supply temperature (chiller 2)	Temperature	F
24	CHW supply temperature, main pipe	Temperature	F
25	CHW return temperature (chiller 1)	Temperature	F
26	CHW return temperature (chiller 2)	Temperature	F
27	CHW return temperature, main pipe	Temperature	F
28	CHW supply flow rate, main pipe	Flow rate	GPM
29	CHW pump1 status	Percentage	%
30	CHW pump2 status	Percentage	%
31	CHW total chillers kW	Power	kW
32	CHW total tonnage	Tonnage	Ton
33	CHW chillers kW/ton	performance	kW/ton
34	Cooling Tower cell1 fan speed	Percentage	%
35	Cooling Tower cell2 fan speed	Percentage	%
36	Cooling Tower cell3 fan speed	Percentage	%
37	Cooling Tower cell4 fan speed	Percentage	%
38	CW supply temperature, entering chiller1	Temperature	F
39	CW return temperature, leaving chiller1	Temperature	F
40	CW supply temperature, entering chiller2	Temperature	F
41	CW return temperature, leaving chiller2	Temperature	F
42	CW supply temperature, to TCW	Temperature	F
43	CW return temperature, from TCW	Temperature	F
44	CW supply temperature, main pipe	Temperature	F
45	CW return temperature, main pipe	Temperature	F
46	CW pump1 status	Percentage	%
47	CW pump2 status	Percentage	%
48	CW flow rate, to chiller1	Flow rate	GPM/ton
49	CW flow rate, to chiller2	Flow rate	GPM/ton
50	CW flow rate, to TCW	Flow rate	GPM
51	CW flow rate, main pipe	Flow rate	GPM
52	HW supply temperature, boiler1	Temperature	F
53	HW supply temperature, boiler2	Temperature	F
54	HW supply temperature, boiler3	Temperature	F
55	HW supply temperature, main pipe	Temperature	F
56	HW return temperature, main pipe	Temperature	F
57	HW flow rate	Flow rate	GPM
58	HW pump1 status	Percentage	%
59	HW pump2 status	Percentage	%
60	HW pump3 status	Percentage	%
61	TCW pump1 status	Percentage	%
62	TCW pump2 status	Percentage	%
63	TCW pump3 status	Percentage	%
64	TW pump1 status	Percentage	%
65	TW pump2 status	Percentage	%
66	TW pump3 status	Percentage	%
67	TW supply temperature	Temperature	F
68	TW return temperature	Temperature	F
69	TW flow rate	Flow rate	GPM

Georgia Institute of Technology: G. Wayne Cough Undergraduate Learning Commons (CULC)

1. Location and Climate

A 250,000 square foot, sustainably-built and operated CULC building located at Georgia Tech campus in Atlanta, GA (Latitude 33.65 N, Longitude 84.43 E) is identified as one of the highly instrumented buildings for the CERC Energy monitoring project. The building is located in DOE climate zone 3A (HDD18-1662 (HDD65-2991) and CDD10-2799 (CDD50-5038)).

Location

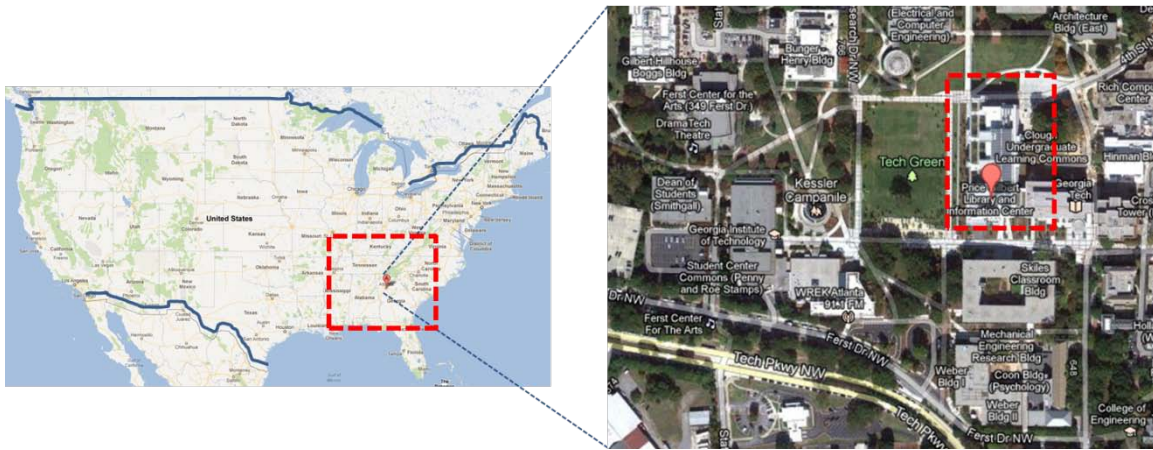

Figure 26 CULC Location

Climate

Table 27 Climate Data (Atlanta, GA)

Month	Unit	Jan	Feb	Mar	Apr	May	Jun	Jul	Aug	Sep	Oct	Nov	Dec	Year
Average High	°C	12	14	18	23	27	31	32	31	28	23	18	12	22
	°F	53	57	65	73	80	87	90	88	82	73	64	54	72
Average Low	°C	1.2	3.2	6.8	11	16	20	22	21	18	12	6.8	2.5	12
	°F	34	38	44	51	60	68	71	71	65	54	44	37	53
Precipitation	mm	107	119	122	85	93	100	134	99	114	87	104	99	1262
	inches	4.2	4.7	4.8	3.4	3.7	4.0	5.2	3.9	4.5	3.4	4.1	3.9	50

Source: NOAA (1961-1990)

2. Building Description



Figure 27 CULC

The facility was designed to demonstrate both academic success and sustainability at work. The building encompasses sustainable design features that will enable LEED (Leading in Energy and Environmental Design) certification with the goal of achieving a LEED Platinum certificate. The project includes a 1.4 million gallon underground cistern which is designed to substantially reduce the amount of storm water GT puts into the City sewer system. The cistern captures runoff from Tech Green and Clough Commons site plus condensate water from the Clough Commons mechanical systems. The captured water is reused for flushing toilets in Clough Commons and landscape irrigation. There are 347 solar panels mounted on the roof of the mechanical penthouse to offset some of the electrical demand to the electric grid. Evacuated tube solar collectors are used to supply hot water to the building. The building is designed to bring day-lighting into its center via 3 light monitors, reducing the energy load. As part of the electrical lighting reduction the building incorporates a "daylight harvesting" system that allows lighting to be turned off in public areas (corridors) when there is sufficient sunlight. The restroom counters are made of recycled glass. An interactive dashboard displays real-time energy and water saving analytics. The building features a roof garden that minimizes and filters storm water runoff, as well as reduces the "heat island effect". The building is heavily instrumented to measure and energy and comfort parameters throughout the building.

Table 28 CULC Building Specifications

Category	Item name	Descriptions
Building information	Name	CULC
	Location	Atlanta, GA
	Year of construction	2012
	Climate zone	ASHRAE Climate Zone 3A
	Type	41 class rooms, 2 300-plus seat auditoria
	number of floor	5 Floors
	Floor area (m2)	23,225 m ² (249,991 ft ²)
	Conditioned area (m2)	20,305 m ² (218,561 ft ²)
	Operation hours	24/7
	Max. Occupancy	N/A
Building Envelope	Exterior wall assembly	Metal frame
	Roof assembly	Metal frame
	WWR	31.3%
	Window	Starphire
	Shading devices	Exterior overhang, Exterior screens
Lighting System	Interior general lighting	T-5
	Interior task lighting	T-5
	Exterior lighting	LED
	Control system	Crestron
	operation hours	24/7
	Lighting Power	N/A
HVAC	cooling system	Campus District
	heating system	Campus District
	Air system	AHU + VAV
	Room set-point	Cooling 23.33C (74F), Heating 21.22C (70F)
	Zone	N/A
	Control system	Johnson Controls
	operation hours	24/7
Internal Equipment & others	Plug load equipment	Office equipment
	Plug load energy	N/A
	Transportation systems	3 elevators
	DHW	Solar water heating, District heating and HX
	Energy generation	PVs
Control & Monitoring	EMS	Metasys
	Energy Monitoring system	ION

3. Building Energy Monitoring System

The CULC building energy (electricity) monitoring structure is illustrated in Figure 28. The main electricity panels/branches are shown in the system level. And individual equipment is listed in the equipment level. The monitoring system point name is given below each monitoring system or equipment. Please note that the central plant equipment energy monitoring is collected in a central plant building.

Monitoring System Diagram

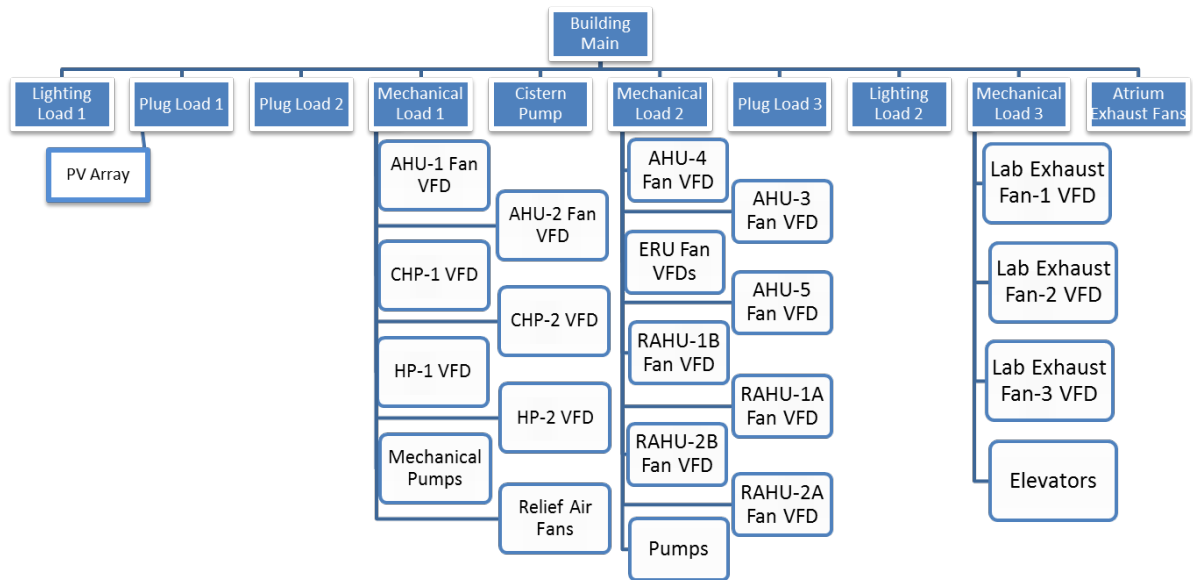

Figure 28 CULC Monitoring Structure

Monitoring point summary

The CULC building monitoring points are shown below. The energy monitoring point has unit either [kWh/interval] for electricity or [btu/hr] for natural gas. The condition monitoring point units vary from points to points.

Table 29 CULC Monitoring Point Summary

Energy Monitoring	Points	Energy Monitoring point num	Condition Monitoring point num	Comments
Lighting	Main lighting branch	2		
Exterior Lighting	Sub-branch	2		
Plugload	Main plug load branch	4		
PV Panels	Inverter off of PV Panels	1		
Equipment	Main AHU and equipments panel	2		
	Individual Air Handling Units	6		
	Exhaust Air Fans	10		
Pumping and DC	Secondary pumps and data center	3		
HVAC water loop	Secondary CHW pumps	2		
	Secondary HW pumps	2		
Transportation	Main elevator branch	1		
Condition Monitoring				
Indoor condition	Room Temperature			
Outdoor condition	OAT			
AHU	AHU SAT			
	AHU supply air flow rate			
	AHU damper position			
Building Occupancy	People Entering		1	
	People Leaving		1	
Building CHW	Entire building		1	
	Individual Air Handling Units		6	
	Chilled Beams		1	
Building HW	Heating HW		1	
	Industrial HW		1	
	Starbucks HW		1	
Building DHW	Steam DHW		1	
	Solar DHW		1	
Total points		35	15	50
Central plant				
HVAC plant loop	Chilled Water Plant Energy	1		Average COP: 4.45
	Boiler Plant Energy	1		Average COP: 0.75
Total points		2	0	2

Monitoring point list

Table 30 CULC monitoring point list

Point ID	Point name	Point Description	Point Type	Unit	File name	Level	Comments
1	B166E_U1 0U2	Solar Panel Power	Electricity	kWhs/interval	CULC Electrical Data-ORNL.csv	System	Sub-category and SUBTRACTED from Point ID #6
2	B166E_U4 H1	Auditorium AHUs and Water Pumps, Mechanical 1	Electricity	kWhs/interval	CULC Electrical Data-ORNL.csv	System	
3	B166E_U7 H1	Penthouse AHUs and Pumps, Mechanical 2	Electricity	kWhs/interval	CULC Electrical Data-ORNL.csv	System	
4	B166E_U1 H1	Lighting 1	Electricity	kWhs/interval	CULC Electrical Data-ORNL.csv	System	
5	B166E_U2 5U6	Lighting 2	Electricity	kWhs/interval	CULC Electrical Data-ORNL.csv	System	
6	B166E_U2 H1	Plug Load 1	Electricity	kWhs/interval	CULC Electrical Data-ORNL.csv	System	
7	B166E_U3 H1	Plug Load 2	Electricity	kWhs/interval	CULC Electrical Data-ORNL.csv	System	
8	B166E_U2 6U6	Plug Load 3	Electricity	kWhs/interval	CULC Electrical Data-ORNL.csv	System	

9	B166E_U1 4U3	Site Lighting, Exterior Lighting 1	Electricity	kWhs/interval	CULC Electrical Data- ORNL.csv	Equipment	Sub-category and included in Point ID #7
10	B166E_U1 5U3	Tech Green Lighting, Exterior Lighting 2	Electricity	kWhs/interval	CULC Electrical Data- ORNL.csv	Equipment	Sub-category and included in Point ID #7
11	B166E_U1 6U4	AHU-1 Fan VFD	Electricity	kWhs/interval	CULC Electrical Data- ORNL.csv	Equipment	Sub-category and included in Point ID #2
12	B166E_U1 7U4	AHU-2 Fan VFD	Electricity	kWhs/interval	CULC Electrical Data- ORNL.csv	Equipment	Sub-category and included in Point ID #2
13	B166E_U2 9U7	AHU-3 Fan VFD	Electricity	kWhs/interval	CULC Electrical Data- ORNL.csv	Equipment	Sub-category and included in Point ID #3
14	B166E_U3 0U7	AHU-4 Fan VFD	Electricity	kWhs/interval	CULC Electrical Data- ORNL.csv	Equipment	Sub-category and included in Point ID #3
15	B166E_U3 1U7	AHU-5 Fan VFD	Electricity	kWhs/interval	CULC Electrical Data- ORNL.csv	Equipment	Sub-category and included in Point ID #3
16	B166E_U3 6U7	ERU Fan VFDs	Electricity	kWhs/interval	CULC Electrical Data- ORNL.csv	Equipment	Sub-category and included in Point ID #3
17	B166E_U1 8U4	CHP-1 VFD	Electricity	kWhs/interval	CULC Electrical Data- ORNL.csv	Equipment	Sub-category and included in Point ID #2
18	B166E_U1 9U4	CHP-2 VFD	Electricity	kWhs/interval	CULC Electrical Data- ORNL.csv	Equipment	Sub-category and included in Point ID #2
19	B166E_U2 0U4	HP-1 VFD	Electricity	kWhs/interval	CULC Electrical Data- ORNL.csv	Equipment	Sub-category and included in Point ID #2
20	B166E_U2 1U4	HP-2 VFD	Electricity	kWhs/interval	CULC Electrical Data- ORNL.csv	Equipment	Sub-category and included in Point ID #2
21	B166E_U2 8U7	Penthouse Pumps: Glycol Pump, Condensate Return Pump-2, Vacuum Pump	Electricity	kWhs/interval	CULC Electrical Data- ORNL.csv	Equipment	Sub-category and included in Point ID #3
22	B166E_U2 2U4	Mechanical Pump Load: Jockey Pump, Low Temperature HWPs, Condensate Return Pump-1, Domestic Water Booster Pumps Process CHWPs, TC	Electricity	kWhs/interval	CULC Electrical Data- ORNL.csv	Equipment	Sub-category and included in Point ID #2
23	B166E_U5 H1	Cistern Pump VFD	Electricity	kWhs/interval	CULC Electrical Data- ORNL.csv	System	
24	B166E_U3 2U7	RAHU-1A Fan VFD	Electricity	kWhs/interval	CULC Electrical Data- ORNL.csv	Equipment	Sub-category and included in Point ID #3
25	B166E_U3 3U7	RAHU-1B Fan VFD	Electricity	kWhs/interval	CULC Electrical Data- ORNL.csv	Equipment	Sub-category and included in Point ID #3
26	B166E_U3 4U7	RAHU-2A Fan VFD	Electricity	kWhs/interval	CULC Electrical Data- ORNL.csv	Equipment	Sub-category and included in Point ID #3
27	B166E_U3 5U7	RAHU-2B Fan VFD	Electricity	kWhs/interval	CULC Electrical Data- ORNL.csv	Equipment	Sub-category and included in Point ID #3
28	B166E_U2 3U4	Relief Air Fans, Exhaust 1	Electricity	kWhs/interval	CULC Electrical Data- ORNL.csv	Equipment	Sub-category and included in Point ID #2
29	B166E_U2 4U6	Lab Exhaust Fan VFDs and Elevators, Exhaust 2	Electricity	kWhs/interval	CULC Electrical Data- ORNL.csv	Equipment	
30	B166E_U2 7U6	Atrium Exhaust Fans, Exhaust 3	Electricity	kWhs/interval	CULC Electrical Data- ORNL.csv	Equipment	
31	B166E_U3 9U24	Lab Exhaust Fan-1 VFD, Exhaust 3	Electricity	kWhs/interval	CULC Electrical Data- ORNL.csv	Equipment	Sub-category and included in Point ID #29
32	B166E_U4 0U24	Lab Exhaust Fan-2 VFD, Exhaust 4	Electricity	kWhs/interval	CULC Electrical Data- ORNL.csv	Equipment	Sub-category and included in Point ID #29
33	B166E_U4 1U24	Lab Exhaust Fan-3 VFD, Exhaust 5	Electricity	kWhs/interval	CULC Electrical Data- ORNL.csv	Equipment	Sub-category and included in Point ID #29
34	Calculated	Elevators	Electricity	kWhs/interval	CULC Electrical Data- ORNL.csv	Equipment	Sub-category and included in Point ID #29
35	B166E_U1 3U3	Starbucks Kitchen	Electricity	kWhs/interval	CULC Electrical Data- ORNL.csv	Equipment	Sub-category and included in Point ID #7
36	Calculated	Chiller Plant Energy	Electricity	kWhs/interval	CULC Electrical Data- ORNL.csv	System	Includes energy for Point ID #40
37	Calculated	Boiler Plant Energy	Electricity and Fuel	kWhs/interval	CULC Electrical Data- ORNL.csv	System	Includes energy for Point ID #48- 52

38		BLDG People In	People Count	Total People	CULC Mechanical Data-ORNL.csv	System	
39		BLDG People Out	People Count	Total People	CULC Mechanical Data-ORNL.csv	System	
40		CHWS Energy Rate	CHW Energy Rate	ton-hrs/interval	CULC Mechanical Data-ORNL.csv	Equipment	
41		AHU-1 Energy Rate	CHW Energy Rate	ton-hrs/interval	CULC Mechanical Data-ORNL.csv	Equipment	Sub-category and included in Point ID #34
42		AHU-2 Energy Rate	CHW Energy Rate	ton-hrs/interval	CULC Mechanical Data-ORNL.csv	Equipment	Sub-category and included in Point ID #34
43		AHU-3 Energy Rate	CHW Energy Rate	ton-hrs/interval	CULC Mechanical Data-ORNL.csv	Equipment	Sub-category and included in Point ID #34
44		AHU-4 Energy Rate	CHW Energy Rate	ton-hrs/interval	CULC Mechanical Data-ORNL.csv	Equipment	Sub-category and included in Point ID #34
45		AHU-5 Energy Rate	CHW Energy Rate	ton-hrs/interval	CULC Mechanical Data-ORNL.csv	Equipment	Sub-category and included in Point ID #34
46		ERU-1 Energy Rate	CHW Energy Rate	ton-hrs/interval	CULC Mechanical Data-ORNL.csv	Equipment	Sub-category and included in Point ID #34
47		Process CHW Energy Rate	CHW Energy Rate	ton-hrs/interval	CULC Mechanical Data-ORNL.csv	Equipment	Sub-category and included in Point ID #34
48		Heating HW Energy Rate	HW Energy Rate	1,000*BTUs/interval	CULC Mechanical Data-ORNL.csv	Equipment	
49		Starbucks HW Energy Rate	HW Energy Rate	1,000*BTUs/interval	CULC Mechanical Data-ORNL.csv	Equipment	
50		Solar Hot Water Energy Rate	HW Energy Rate	1,000*BTUs/interval	CULC Mechanical Data-ORNL.csv	Equipment	
51		Domestic HW Energy Rate	HW Energy Rate	1,000*BTUs/interval	CULC Mechanical Data-ORNL.csv	Equipment	
52		Industrial HW Energy Rate	HW Energy Rate	1,000*BTUs/interval	CULC Mechanical Data-ORNL.csv	Equipment	

EPA National Computer Center (NCC)

1. Location and Climate

EPA NCC is located in Durham, NC, which is in Climate zone 4A (Mixed-Humid). Climate zone 4A is defined with CDD $10^{\circ}\text{C} \leq 2500$ and HDD $18^{\circ}\text{C} \leq 3000$.

Location

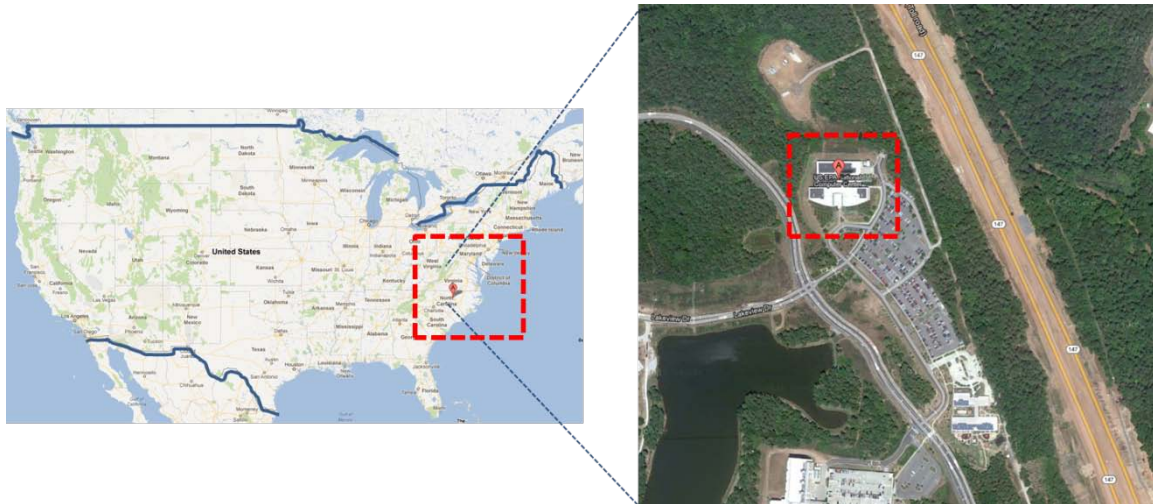

Figure 29 NCC Location

Climate

Table 31 Climate Data (Durham, NC)

Month	Unit	Jan	Feb	Mar	Apr	May	Jun	Jul	Aug	Sep	Oct	Nov	Dec	Year
Average High	$^{\circ}\text{C}$	9.6	12	17	22	26	29	31	30	27	22	17	12	21
	$^{\circ}\text{F}$	49	53	62	71	79	85	89	87	81	71	62	53	70
Average Low	$^{\circ}\text{C}$	-2.3	-1.4	2.8	7.7	13	19	21	20	16	8.1	3.0	-0.9	8.8
	$^{\circ}\text{F}$	28	30	37	46	56	65	70	68	60	47	37	30	48
Precipitation	mm	113	94	119	87	117	102	100	111	111	94	86	87	1220
	inches	4.4	3.7	4.7	3.4	4.6	4.0	4.0	4.4	4.4	3.7	3.4	3.4	48

Source: NOAA (1971-2000)

2. Building Description



Figure 30 NCC Building

Table 32 NCC Building Specifications

Category	Item name	Descriptions
Building information	Name	National Computer Center (NCC)
	Location	Durham, NC
	Year of construction	2001
	Climate zone	ASHRAE Climate Zone 4A
	Type	Office (50%), Data Center (50%)
	number of floor	2 Floors
	Floor area (m2)	9,376 m ² (100,890 ft ²)
	Conditioned area (m2)	N/A
	Operation hours	M-F 7:00am - 6:00pm (average)
	Max. Occupancy	250 people
Building Envelope	Exterior wall assembly	CMU, Precast Concrete
	Roof assembly	Single-ply 60mil EPDM membrane
	WWR	About 20%
	Window	Low-e film/tinted double pane window
	Shading devices	Interior blinds
Lighting System	Interior general lighting	T-8
	Interior task lighting	fluorescent tube
	Exterior lighting	N/A

	Control system	Occupancy sensors in office spaces
	operation hours	M-F 7:00am - 6:00pm (average)
	Lighting Power	16.2 W/m ² (1.5 W/ft ² , Design Criteria)
HVAC	cooling system	District chilled water with airside economizer
	heating system	Gas Boiler
	Air system	VAV
	Room set-point	N/A
	Zone	N/A
	Control system	TAC INET-7
	operation hours	M-F 7:00am - 6:00pm (average)
Internal Equipment & others	Plug load equipment	Office equipment
	Plug load energy	31.4 W/m ² (10 Btu/ft ² hr, Design Criteria)
	Transportation systems	2 elevators (Office), 1 elevator (Data center)
	DHW	Electric water heater
	Energy generation	75 kW Solar PV array
Control & Monitoring	EMS	TAC INET-7
	Energy Monitoring system	Schneider Electric ION

3. Building Energy Monitoring System

Monitoring System Diagram

Figure 31 illustrates the structure of power use monitoring based on end uses. The main electricity categories are shown at the top of the diagram: at the system level. Individual equipment is listed below: at the equipment level. Each monitoring point name is indicated under the corresponding monitoring system or equipment. The monitoring data will be recorded in CVS format. The monitoring interval is 15 minutes.

In Figure 31, yellow filled indicates meters installed and working currently. Purples show data centers and Reds represent meters only for office. WB is short for whole building, while WBE is short for whole building electricity.

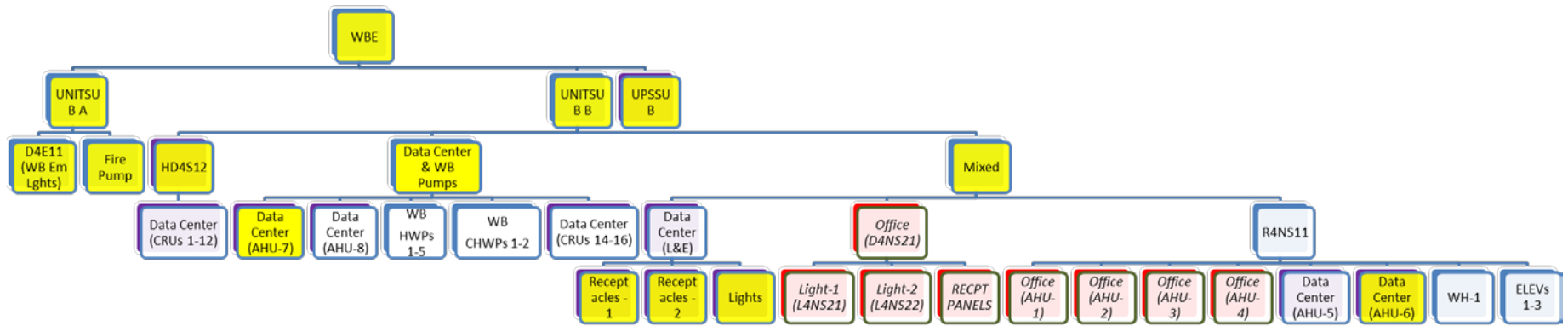

Figure 31 NCC Monitoring Structure

Monitoring Points List

Table 33 NCC Energy Monitoring Points by End Use - HVAC

# of AC per point	# of the AC	Floor	Name of the point	Type of point
*2 AC	AHU-1 and AHU-2	1	HVAC - AHU1_2	Monitored
*2 AC	AHU-3 and AHU-4	1	HVAC - AHU3_4	Monitored
1 AC	AHU-6	2	HVAC-AHU6	Monitored
1 AC	AHU-7	2	HVAC-AHU7	Monitored
13 CRAC	CRU-1 to CRU-13	2	HVAC - HD4S12	Monitored
*2 CHWP	CHWP-1 and 2	1	HVAC - CHWP1_2	Monitored
*3 HHWP	HHWP- 1 to 3	1	HVAC-HHWP1_3	Monitored

Table 34 NCC Energy Monitoring Points by End Use - Lighting

Name of the point	Floor	Type of point
Emergency Lights	1 and 2	Monitored
Lights- Data Center	2	Monitored
*Lights-Office	1 and 2	Monitored

Table 35 NCC Energy Monitoring Points by End Use - Natural Gas

Name of the point	Type of point
HVAC - Boiler_Gas (Ccf)	Monitored

Table 36 NCC Energy Monitoring Points by End Use - Chilled Water

Name of the point	Type of point
HVAC- Whole Building CHW (kBtu)	Monitored
HVAC-Data Center CHW (kBtu)	Monitored

Table 37 NCC Energy Monitoring Points by End Use - Heating Hot Water

Name of the point	Type of point
HVAC- Data Center HHW (kBtu)	Monitored

Table 38 NCC Energy Monitoring Points by End Use - Electric Domestic Water Heater

Name of the point	Type of point
*WH-1	Monitored

Table 39 NCC Energy Monitoring Points by End Use – Plug Loads

Name of the point	Type of point	Calculation
Receptacles-Data Center	Monitored	
*Receptacles and Lights- Office	Monitored	
*Receptacles- Office	Calculated	(Receptacles and Lights- Office)-(Lights-Office)

**: currently installed and working points*

Appendix D – Sourcebook of Case Study Buildings: Energy Analysis



Sourcebook: Energy Analysis of Case Study Buildings in the U.S. and China

*U.S. China Clean Energy Research Center for Building
Energy Efficiency (CERC-BEE)*

The U.S. Team: LBNL, ORNL

The China Team: Tsinghua University

11/18/2012

Contents

Introduction to Project	3
Chinese Buildings.....	3
1. Introduction to Chinese sub-metering categories:	3
1.1 Lack of heating load information.....	3
1.2 Other missing data	4
2. Case Study Building A	6
2.1 Basic Information.....	6
2.2 Annual Data	6
2.3 Monthly Analysis	8
2.3.1 District Heating Influences	9
2.3.2 Influence of Holidays on Energy Consumption	9
2.4 Weekly Analysis	10
2.5 Daily Analysis	11
2.5.1 Weekday Analysis	11
2.5.2 Weekend Analysis.....	12
2.5.3 Base vs. Peak-load	12
2.6 Seasonal Analysis.....	13
2.7 Chiller COP analysis	14
2.8 Building A Summary	14
3. Case Study Building B	15
3.1 Basic Information.....	15
3.2 Annual Data	15
3.3 Monthly Analysis	17
3.4 Weekly Analysis	18
3.5 Daily Analysis	18
3.6 Seasonal Analysis.....	19
3.7 Building B Summary.....	19
American Buildings	21
4. Case Study Building 1	21
4.1 Basic Information.....	21
4.2 Major Data Problems.....	21
4.2.1 Missing Quantitative Data	21

4.2.2	Specific Missing Data	22
4.2.3	Condensing Water Pumps data	22
4.2.4	Sub-items Shared by both Wings	22
4.3	Special Case: District Cooling System	22
4.4	Annual Data	24
4.5	Monthly Data	26
4.6	Daily Analysis	27
4.7	Seasonal Analysis	28
4.8	Plant Chiller COP	28
4.9	Case Study Building 1 Summary	29
5.	Case Study Building 2	30
5.1	Basic Information	30
5.2	Major Data Problems	30
5.2.1	Missing and Negative Energy Data	30
5.2.2	Calculated points	31
5.2.3	Irrational Gas Data	31
5.2.4	Missing Condition Data	31
5.2.5	Rough sub-metering	31
5.3	Electricity Data Analysis	32
5.3.1	Annual Data	32
5.3.2	Monthly Data	34
5.3.3	Seasonal Analysis	36
5.3.4	Weekly Analysis	37
5.3.5	Daily Analysis	41
5.4	Gas Consumption Analysis	43
5.5	Case Building 2 Summary	44

Introduction to Project

This project is a joint project involving Tsinghua University, Lawrence Berkeley National Lab and Oakridge National Lab for the U.S. China Clean Energy Research Center on Building Efficiency. The goal is to decode the driving forces behind the discrepancy of building energy use between the two countries; identify gaps and deficiencies of current building energy monitoring, data collection, and analysis; and create knowledge and tools to collect and analyze good building energy data to provide valuable and actionable information for key stakeholders.

In this sourcebook, specific reports on the analysis of four individual buildings (two in the U.S. and two in China) are displayed respectively. More detailed information about all the buildings selected in this project can be found in an accompanying document titled “Sourcebook: Information of Case Study Buildings in the U.S. and China”. More detailed information about lessons learned from this project so far can be found in another accompanying document titled “Lessons Learned from Benchmarking Commercial Buildings in the U.S. and China: Challenges and Methods”.

Chinese Buildings

1. Introduction to Chinese sub-metering categories:

The buildings in China are sub-metered at different levels/points in China than they are in the United States. Figure 1 is the breakdown of the different sub-levels. Because these sub-levels are different, it is a challenge to compare energy consumption data of Chinese buildings to that of American buildings. However, it is convenient to compare Chinese buildings with each other, as these sub-categories are standardized for the buildings that Tsinghua monitors.

1.1 Lack of heating load information

Since buildings in Beijing are served by a district heating system, there is no data on heating loads. Heating is provided by the government, from November 15th to March 15th of the next year, and paid for by square footage and the amount of heat provided depends on outside air temperature for the district.

However, individual buildings will still have information for the primary/secondary pumps, AHUs and other building-specific equipment associated with providing heat to the occupants inside of the building. Essentially what is missing is the boiler energy consumption.

1.2 Other missing data

Unfortunately at the time of the installation of the meters, there was no installation of meters that read indoor/ outdoor air temperature and humidity. Therefore indoor/outdoor conditions must be estimated until meters are instead.

Supply and return water temperatures are also not monitored on a regular interval. Average values are taken when doing site specific surveys, but these meters must also be installed in Chinese buildings in the future.

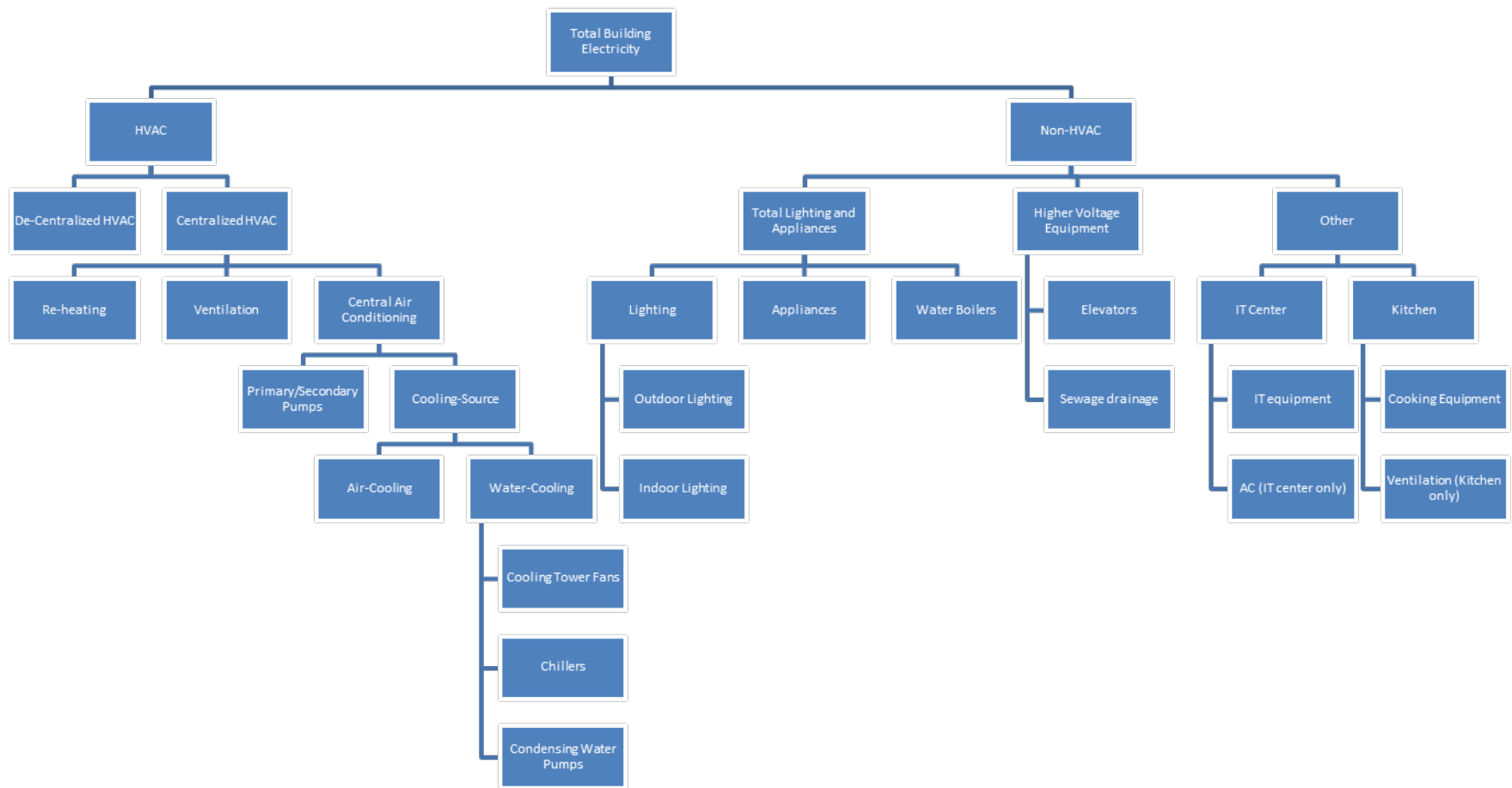

Figure 1: Sub-metering categories for Chinese buildings

2. Case Study Building A

2.1 Basic Information

Building A, located in Beijing, China, is a large, mixed-use commercial office building with some restaurants, stores, and a bank. It consists of a tall main building with large glass curtain walls and an annex.



Total floor area: 54490 m²

Approximate number of occupants: 1800

Operation Set Points and Requirements

- Indoor Temperature: Winter: 22-24°C. Summer: 24-26 ° C.
- Indoor Humidity: Winter: 35%-45%, Summer: 50%-65%
- HVAC Operation hours: 7:00am-6:00pm

2.2 Annual Data

During the period of September 2010-August 2011, the annual electricity consumption was approximately 122kWh/m² or 6,647,780 kWh per year.

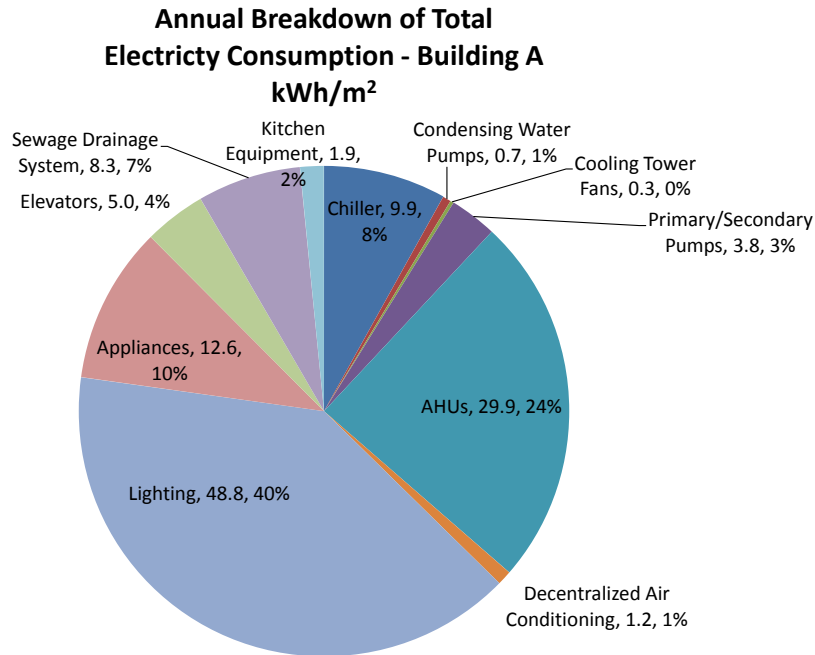

Figure 2: Annual breakdown of electricity consumption of Building A according to the most specific categories in the Chinese sub-category tree. Listed by category name, kWh/m² per year, percentage of total energy usage

This performance can be compared with total electricity consumption of previous years, and is slightly below the most recent available data for 2003, shown in the following chart.

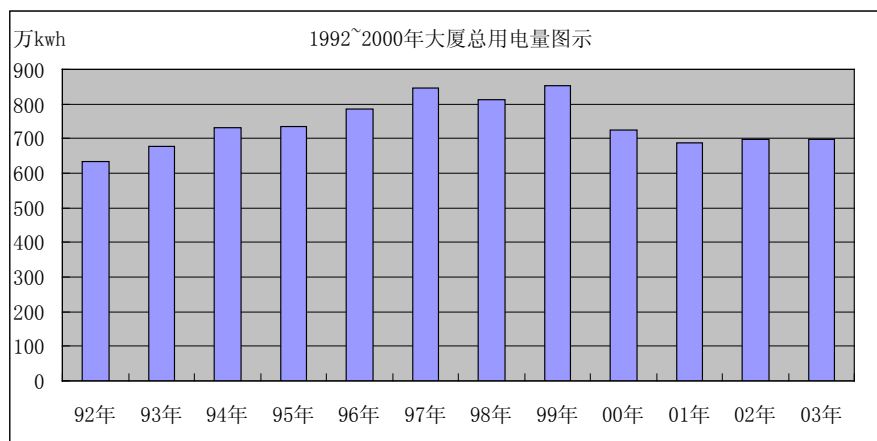

Figure 3: Previous years' total electricity consumption of Building A

The annual data can be displayed in many different ways. Figure 4 shows a breakdown of the annual energy consumption according to ISO standard 12655. "Other Ultimate Usages" includes indoor transportation and building auxiliary devices. "Other Special Usages" includes cooking, cooling storage, devices in data center and other specific functional devices.

**Total Annual Energy Consumption - Building A:
ISO 12655 [first tier]
kWh/m²**

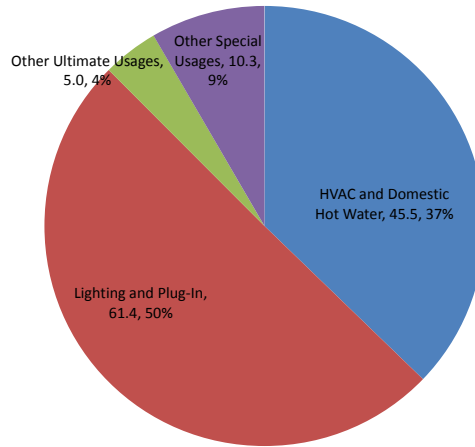

Figure 4: Annual breakdown of total electricity consumption of Building A according to ISO 12655 first tier sub-categories

2.3 Monthly Analysis

The following chart shows the monthly changes in energy consumption of this building.

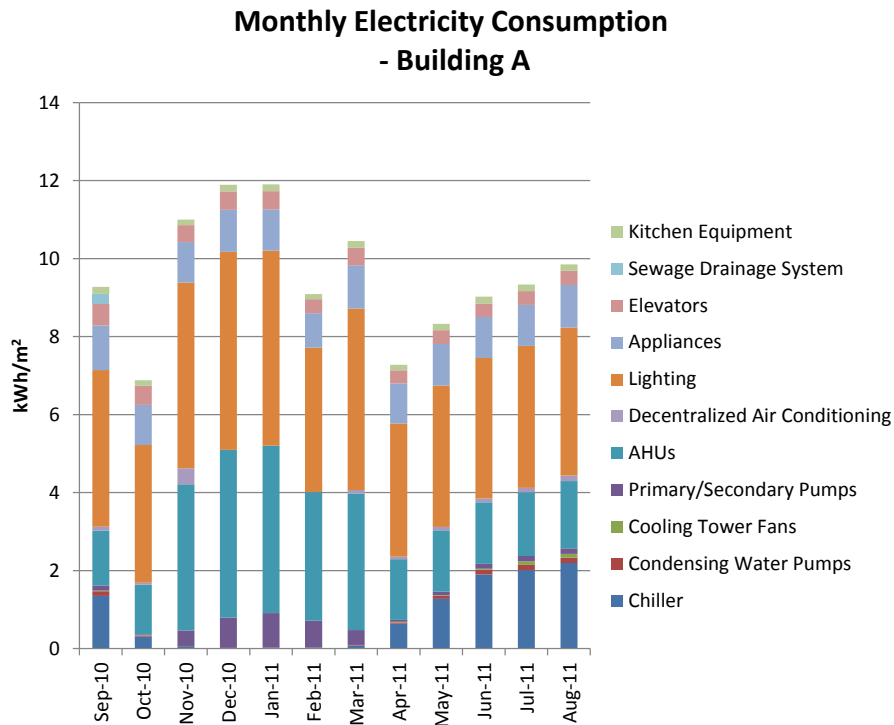

Figure 5: Building A monthly electricity breakdown from September 2010-August 2011

2.3.1 District Heating Influences

The district heating is provided from November 15th to March 30th of the following year. As shown in these charts, this period of time is precisely when the primary/secondary pumps and the AHUs have a large increase in energy usage.

More research should be done with occupant comfort to see whether the building is overheated, and if it is possible to adjust the valve from the district heating source.

2.3.2 Influence of Holidays on Energy Consumption

(1) October 2011

There is a sudden drop in energy consumption from September 2010 to October 2010 because mid-way through October, the chiller was turned off. Additionally, less energy was used overall during the first week of October, during the National Day Golden Week holiday.

(2) February 2011

It is seen that February has an unusually small energy consumption load, even though the district heat is still being provided. In addition to February only having 28 days instead of 31 (as January and March both do), February's low energy consumption is mainly due to the Chinese Spring Festival. Below is the lighting load in the month of February, which was an example taken to show that during the holiday surrounding the day of the lunar New Year's Day (February 3rd), the consumption levels were the same as those at weekends.

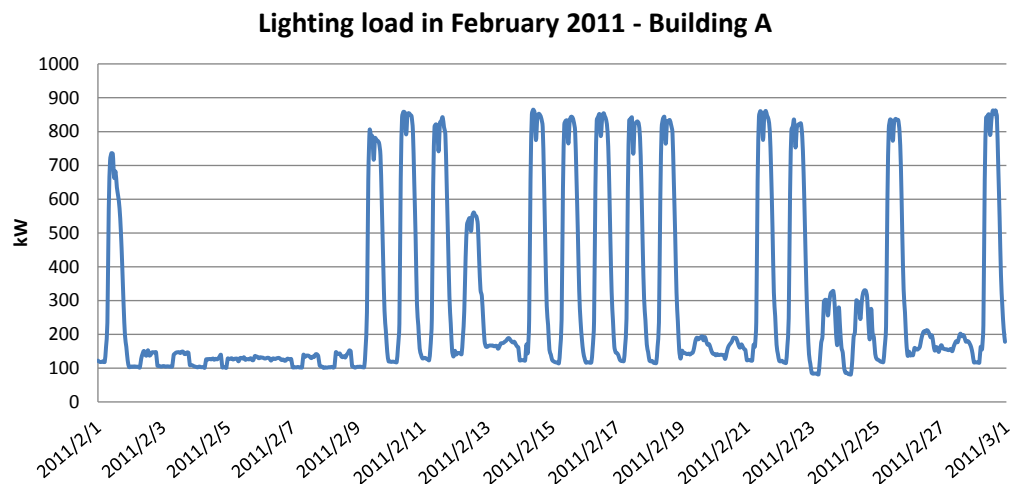

Figure 6: Building A's lighting load in February 2011

Note: It can also be seen that the days of February 23 and 24, the consumption was also a bit lower than average. More information is needed to find the reason behind it.

2.4 Weekly Analysis

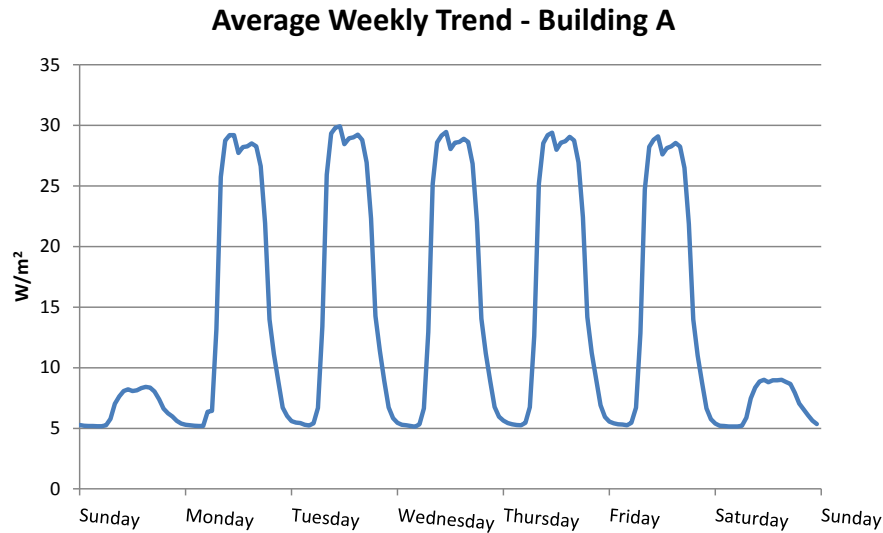
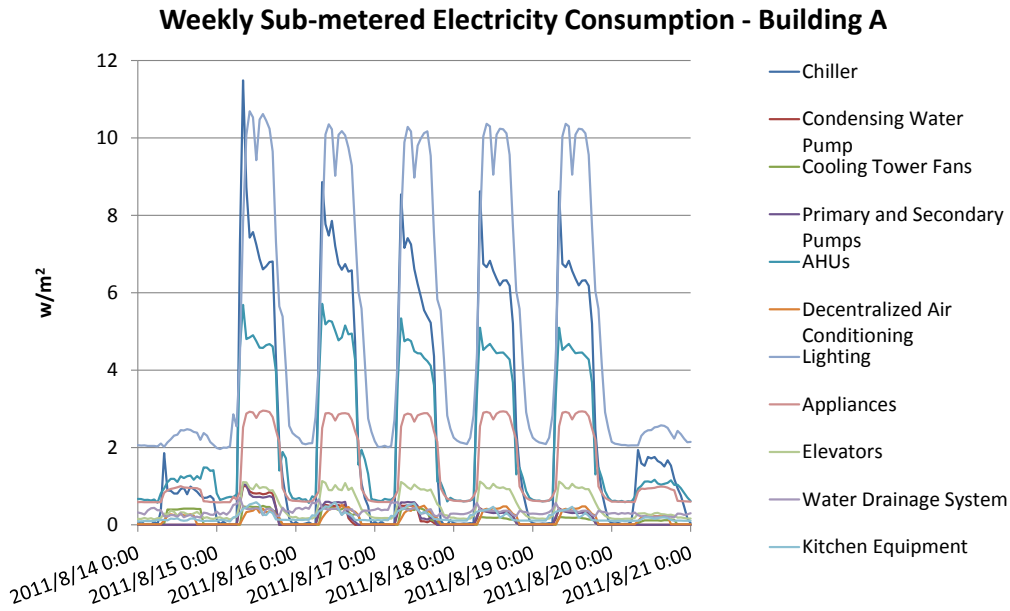

Figure 7 is a chart of the energy consumption showing the breakdown equipment over the week of August 14, 2011 through August 20, 2011. Figure 8 is the average of all weeks in one year, which gives a glimpse at what energy consumption looks like in an average week.

There are clear differences between the energy consumption on weekends versus the consumption on the weekdays, which is to be expected of proper building management.

2.5 Daily Analysis

Below is a further in-depth look at the trends for daily equipment operation.

2.5.1 Weekday Analysis

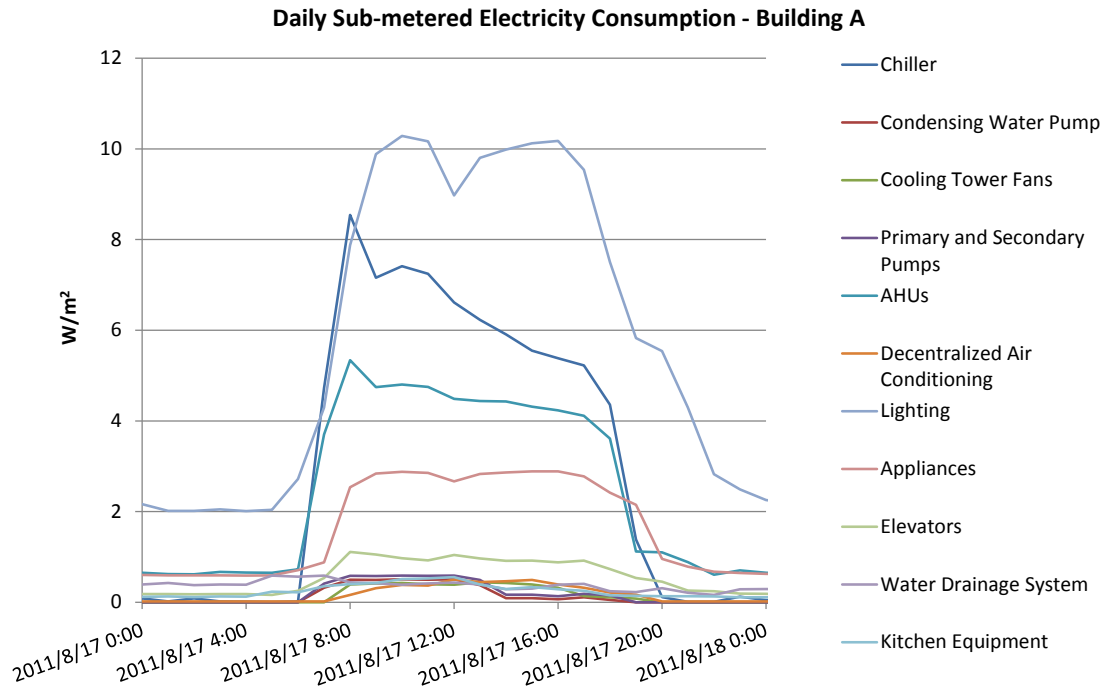

Figure 9: Typical weekday consumption trend of Building A (August 17, 2011)

In the mornings during the start of the operation period, the chiller and AHUs have large start-up energy consumption.

It is also interesting to see that during the lunch hours, there is a decline in lighting and appliance electricity. This means that occupants are conscious of the fact that they should turn off unneeded appliances.

2.5.2 Weekend Analysis

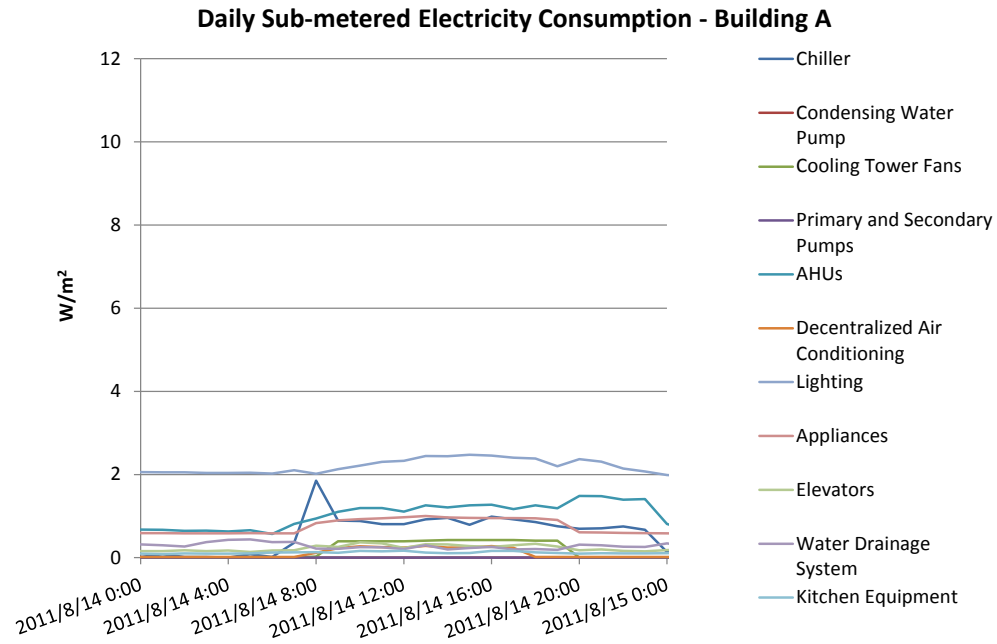

Figure 10: Typical weekend consumption trend of Building A (August 14th, 2010)

It is very clear that equipment is nearly not used over the weekend. However, there is still a small start-up peak in the mornings from the chillers.

2.5.3 Base vs. Peak-load

Figure 11 was created by taking averages of daily energy consumption trends of all weekdays and weekends over an entire year.

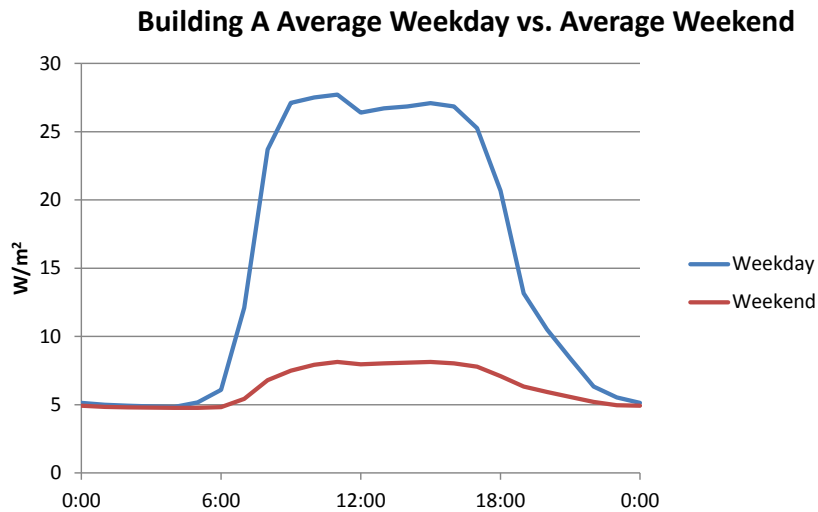

Figure 11: Building A average weekday versus weekend total energy consumption

According to the shapes of the energy demand, it seems as if equipment operation is mainly on from 6:00am-21:00pm.

Using this time period, on weekdays, the average peak demand is 21.01 W/m^2 , and the average base load is 5.21 W/m^2 . Therefore, on average, the base load is about 24.8% of peak load.

For weekends, the average peak demand is about 7.10 W/m^2 , average base demand is about 4.89 W/m^2 , which means the base load is 68.89% of peak load.

2.6 Seasonal Analysis

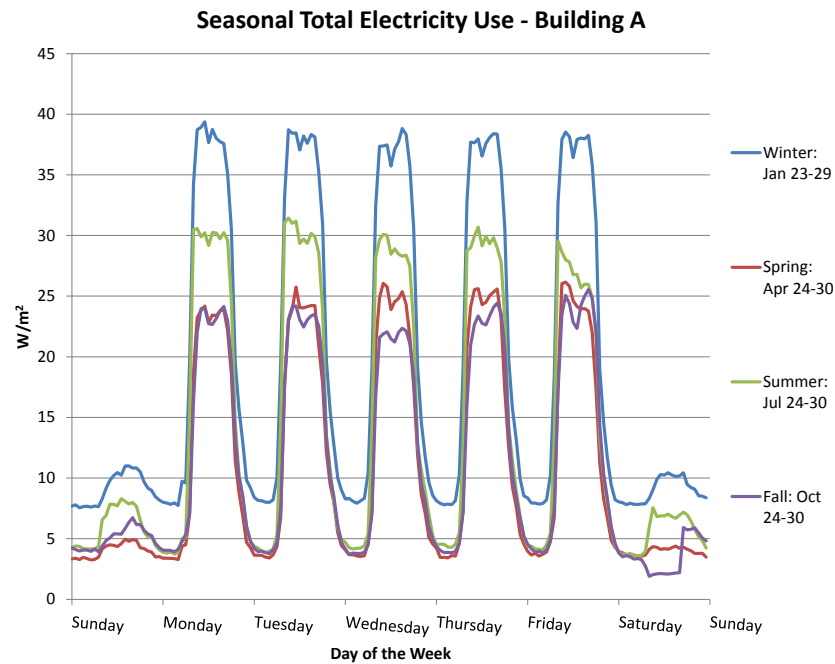

Figure 12: Building A seasonal differences in energy consumption

In order to see the seasonal differences in energy consumption, typical weeks out of all four seasons, winter, spring, summer and fall, were chosen as examples and compared to each other. These weeks were selected based on when the season started, and is usually the 5th or 6th week into the respective season.

Not surprisingly, winter and summer are the seasons with the highest energy consumption. The winter season is considerably more energy intensive due to the equipment associated with the district heating load. Hot water is distributed from the city's district heating system, and pumped through the building. Air handling units then transfer the heat into the rooms. Therefore, the increase in winter energy consumption is mainly due to the secondary pumps and AHUs. It can be inferred that if the energy of the boiler were added, the winter energy usage would be even larger.

This is an interesting difference compared to buildings in the United States that use more energy in the summer, largely because of air conditioning loads. The fact that this Chinese building uses

less energy in the summer means that air conditioning is not turned on as high, relative to conditioning loads in the United States.

2.7 Chiller COP analysis

Previous analysis was done on chiller COP in 2009. The following is the data recorded from 07/13/2009 to 07/21/2009.

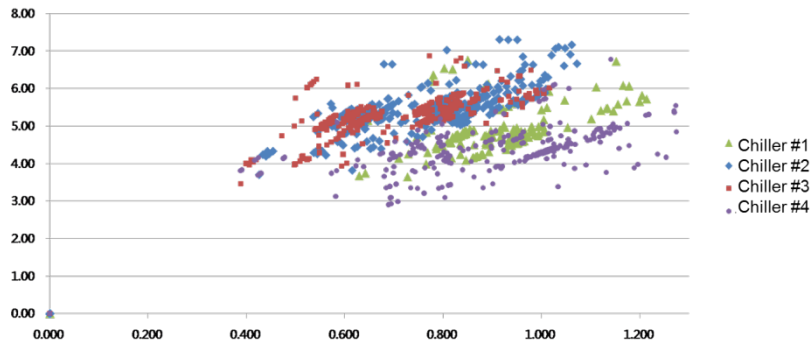

Figure 13: Scatter plot of chiller COPs

	Average COP
Chiller 1	4.87
Chiller 2	5.45
Chiller 3	5.35
Chiller 4	4.36

Figure 14: Average COP values

These values for COP are average, as the average value for medium to large chillers usually ranges from 3.5 to 7.0.

2.8 Building A Summary

It can be concluded that this building is operated relatively ideally. This can be seen from the comparison with both typical Chinese buildings and American buildings.

From a more detailed look, the building also exhibits efficient operation in terms of operation when there are occupants in the building versus not in the building. This saves a tremendous amount of energy.

This building's operation efficiency may be a factor of the building's close relationship with Tsinghua, as it has undergone many years of study and the relationship between the building managers and researchers is quite good.

3. Case Study Building B

3.1 Basic Information

Building B, located in Beijing, China, is a government administrative mixed use office building, served by decentralized cooling systems and district heating with radiators.



Total floor area: 39211 m²

3.2 Annual Data

The following is a graph of annual electricity usage per square meter from July 2011 to June 2012. Within this period of time, the annual electricity consumption was approximately 114.2kWh/m² or 4,475,987 kWh per year.

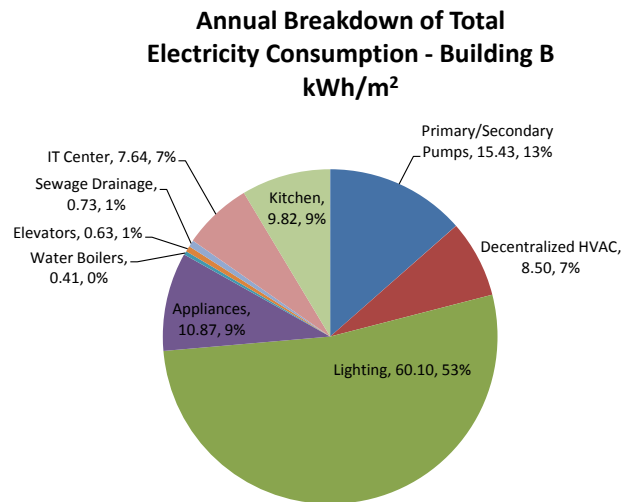
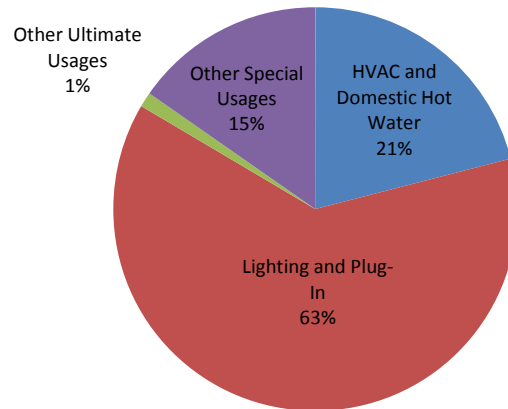

Figure 15: Annual breakdown of electricity consumption of Building B according to the most specific categories in the Chinese sub-category tree.

**Total Annual Energy Consumption - Building B:
ISO 12655 [first tier]
kWh/m²**



**Figure 16: Annual breakdown of total electricity consumption of Building A
according to ISO 12655 first tier sub-categories**

Above is a breakdown of the annual energy consumption according to the first tier of ISO standard 12655, which is the most general tier. “Other Ultimate Usages” includes indoor transportation and building auxiliary devices. “Other Special Usages” includes cooking, cooling storage, devices in data center and other specific functional devices.

Second tier breakdowns are not available for this building, as there was no way to differentiate “Air Movement” from “Space cooling” from the decentralized HVAC system.

3.3 Monthly Analysis

Below is a chart that shows the monthly changes in energy consumption.

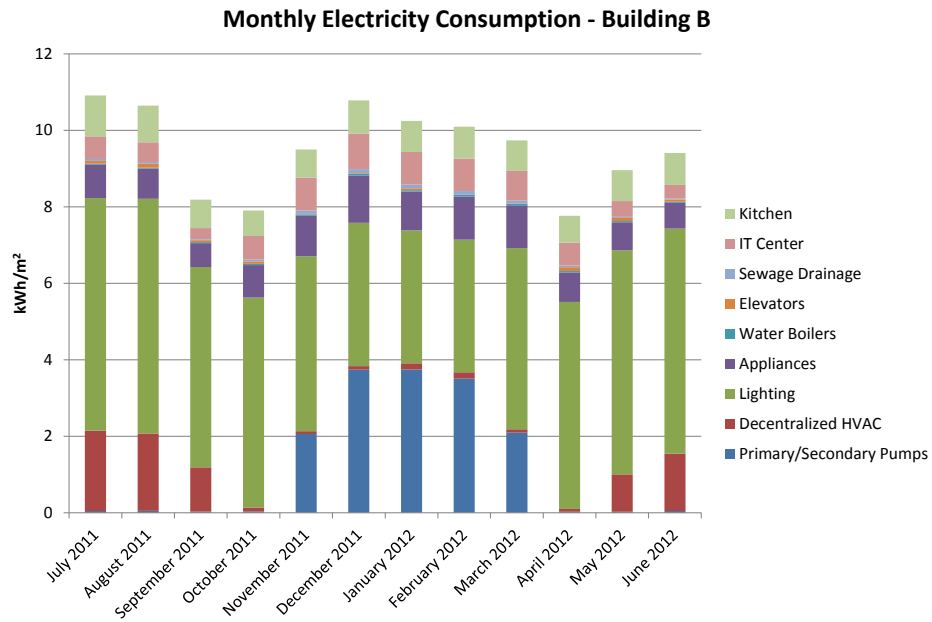

Figure 17: Building B monthly electricity breakdown from September 2010-August 2011

Similar to case study building A, district heating largely affects the energy consumption during the winter months.

Interestingly, precisely around the district heating time period, lighting intensity decreases. This is possibly due to the fact that the sun is stronger in the summer. Therefore, to prevent glare, curtains or blinds would be drawn over the windows, which would necessitate indoor lighting.

3.4 Weekly Analysis

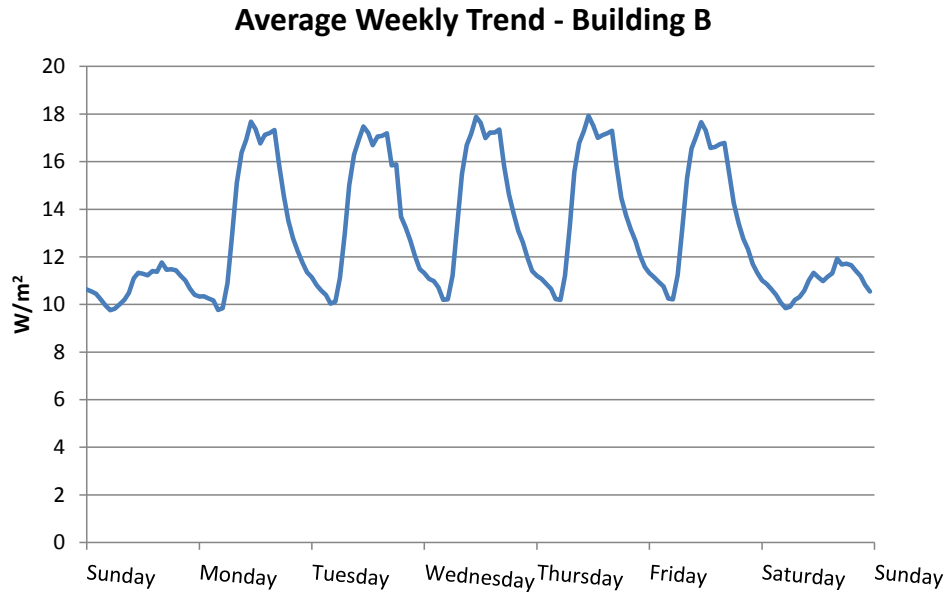

Figure 18: Building B Average Weekly Energy Consumption Trend

Figure 18 shows weekly energy consumption averaged over the entire year. There are clear differences between the energy consumption on weekends versus the consumption on the weekdays, which is to be expected of proper building management. It can be inferred that operation for weekdays and weekends are similar respectively across the whole week.

3.5 Daily Analysis

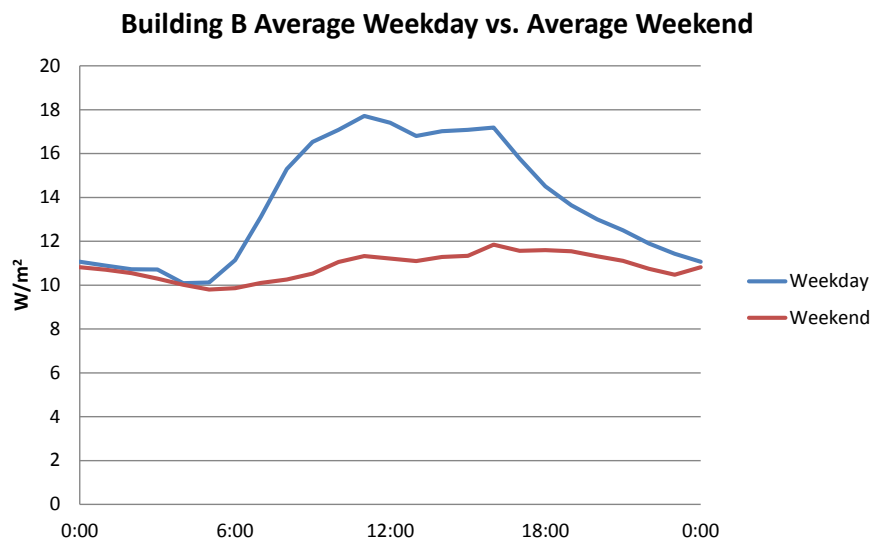

Figure 19: Building B average weekday versus weekend total energy consumption

Similar to Building A, there is a decline in lighting and appliance electricity during the lunch hours.

According to the shapes of the energy demand, it seems as if equipment operation is mainly on from 6:00am-21:00pm.

Using this time period, on weekdays, the average peak demand was 15.4 W/m^2 , and the average base load was 10.9 W/m^2 . On average, the ratio of the base load to the peak load is 70.8%. Similar to Building A, energy consumption dips a bit during the noontime break.

For weekends, the average peak demand is about 11.1 W/m^2 , and average base demand was 10.5 W/m^2 , which means the base load is 94.6% of peak load. It is clear that for the weekends, there is hardly a peak in demand, as energy usage is the same throughout the day.

3.6 Seasonal Analysis

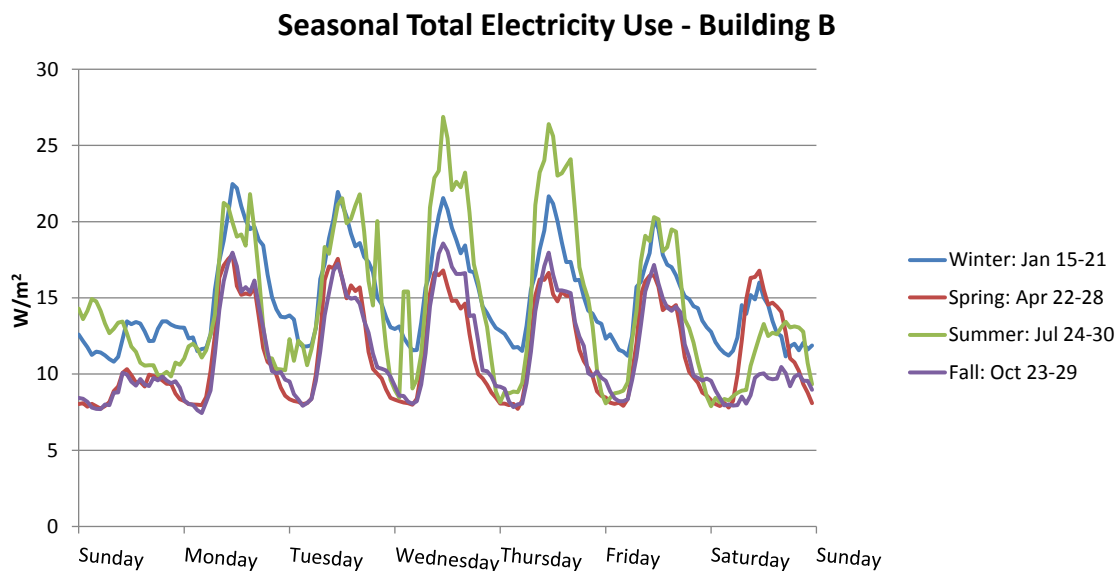

Unlike Building A, Building B's most intensive season is summer, not winter. This is mainly due to the fact that in Building A, pumps associated with district heating were added onto total energy consumption of the winter months, whereas in Building B, this increase in energy associated with district heating was offset by the decrease in the lighting energy intensity.

3.7 Building B Summary

Building B uses a larger proportion of lighting, which, as mentioned before, is largely in use in spring, summer and fall. Perhaps a further investigation would give more inside into why lighting is so different in winter, and whether or not lighting energy intensity can be lowered to winter-like levels all year-round.

HVAC energy consumption associated with air conditioning in the summer months is relatively low. This is because the air conditioning system is decentralized, which would allow for better

control for specific spaces. It would be interesting to see how temperature set points vary from actual indoor conditions.

Building B is a government building in China, and therefore should set the standard for energy efficiency for other buildings to follow.

American Buildings

4. Case Study Building 1

4.1 Basic Information

This building is located on a campus in climate zone 3 in California, the United States. It is a mixed-use building with a library wing (9,000 m²) and an office wing (7,000 m²), and is served by the campus' district cooling and heating systems. The following analysis is only based on the office wing. This building was newly built with a design energy goal of 38% greater energy efficiency than the 2001 California Title 24 standards.

There are 7 HVAC technicians and a total of 15~20 general technicians (electric, HVAC, plumbing, etc.) on campus. Technicians work on a ticket-based operation and management system. No technician is designated to specific buildings. There is one building designated manager per building.



Total floor area: 16,000m² (7,000m² for office wing)

4.2 Major Data Problems

4.2.1 Missing Quantitative Data

There were major problems with data quality in this building. In a given month, an average of about seven days' worth of data was not recorded into the system (sometimes data would be lost for a couple days, and other times it would be for a few hours in one single day).

Though there was no pattern to the lost data, it can be noted that most of the data was missing around the weekend time periods or over holidays, presumably when there is no one present for keeping the system online. There also seemed to be many times when data at the 0:30 a.m. was lost as well.

In order to get the data in workable order to calculate annual energy consumption, the lost data was replaced by hand with time periods or days that were similar to the missing points. For example, a missing weekend would be replaced by the previous or following weekend's

completed data, or missing afternoon data would be replaced with afternoon data from the previous or following day.

4.2.2 Specific Missing Data

The meter labeled “breaker_cdp_0201_kwtr_7484” was described as secondary pumps and data center”, so in order to isolate the data center, we tried to subtract the energy usage of the secondary pumps. However, once these values were subtracted, negative numbers were given for the data center, which is odd, especially because data centers are on 24/7. For the purposes of the below analysis, it was assumed that this meter was only the data center, and no additional pumps.

4.2.3 Condensing Water Pumps data

Though there’s no energy consumption data for condensing water pumps in the district cooling plant, the real-time on-off status of these pumps are available at a 15-min interval, same as that of other end-use energy data. Given the rated power of each pump, the energy use data of CWP can be roughly estimated for further calculation.

4.2.4 Sub-items Shared by both Wings

It’s important to note that some sub-items in this building are shared by both the office wing and the library wing. When calculating the energy use intensity, the total area of 16,000 m² was used for sub-items that involve the whole building, while 7,000 m² was used for sub-items that only involve the office wing. As an exception, while the elevator is an electricity end-use shared by both wings, the library wing, with more floating people and a longer operation time, has much higher elevator use rate than the office wing. Therefore to split the elevator electricity use, the office wing is roughly considered to account for only 25% of the total.

4.3 Special Case: District Cooling System

The cooling and heating is provided by district systems that service the entire campus. There was no exact data on how much energy/tonnage was sent to specific buildings on campus. Therefore, a ratio based on cooling tonnage consumed by total buildings on campus to total cooling tonnage of the office/library building was used to roughly estimate the percentage of plant equipment energy (chillers, pumps, and cooling towers) that was used by this specific building. This ratio was calculated for each month. Results are as shown.

	Cooling Tonnage Ratio
June 2011	0.251
July 2011	0.213
August 2011	0.230
September 2011	0.184
October 2011	0.212
November 2011	0.243
December 2011	0.230
January 2012	0.170
February 2012	0.167
March 2012	0.179
April 2012	0.247
May 2012	0.201

Figure 21: Ratio of tonnage consumed by case study building to tonnage consumed by all buildings on campus

The campus provides cooling from a district cooling plant. In addition, the chillers and cooling towers run at night when electricity prices are cheaper. The chilled water is then stored in a tank to provide cooling during the day time.

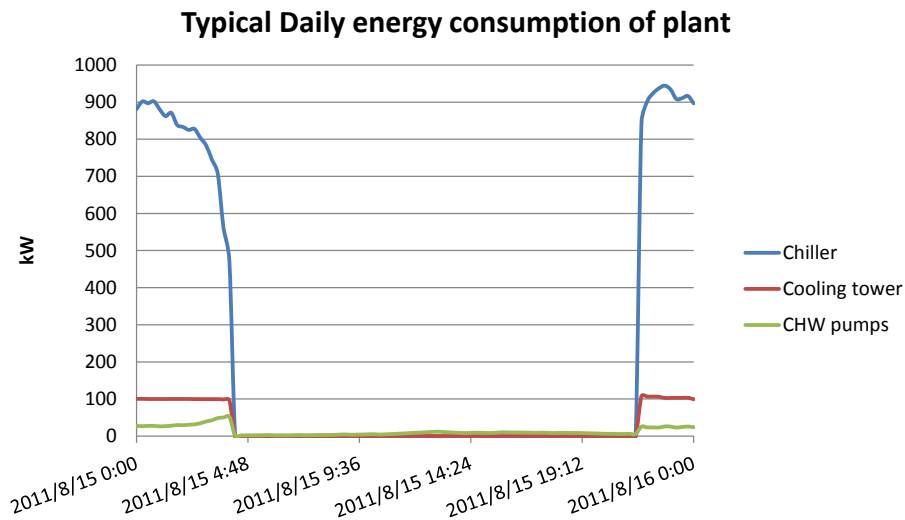

Figure 22: Typical daily operation trend for district plant (August 15, 2011)

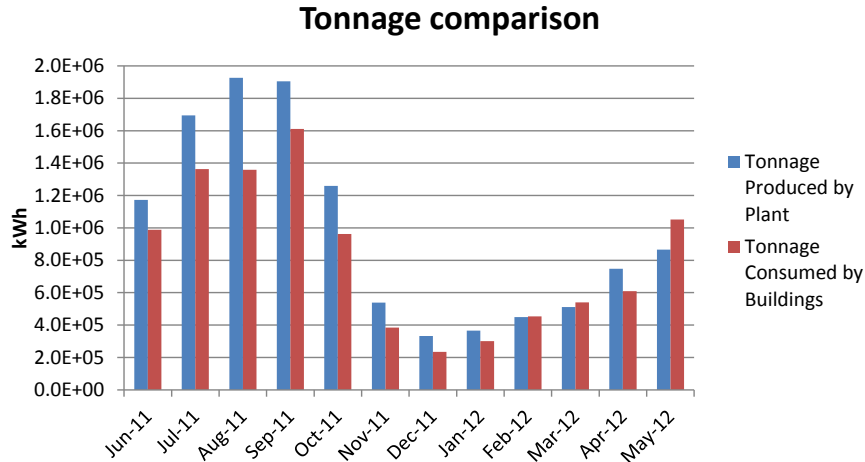

Figure 23: Tonnage comparison between chilled water produced by the plant chiller and chilled water consumed by all buildings on campus

Figure 23 shows the tonnage produced by the plant monthly when it is on at night versus the tonnage consumed by all buildings on campus 24 hours. On an annual average, tonnage consumed by the building is about 84% of tonnage produced by the plant.

There is an oddity in the data several months in 2012, February, March and May. It seems as if tonnage consumed by the buildings was larger than the tonnage produced by the plant, which is impossible if all of the cooling from buildings is coming from the plant. Upon further analysis, it was found that the point that monitored the return water to the tank measured colder values than the point monitoring the supply water to the chillers.

Take May for example, the average difference of supply/return water consumed by buildings was 11.14 degrees C, but the average difference of supply/return water produced by the plant was 8.18 degrees C. This difference mainly had to do with the return water, as the supply water was kept relatively constant at around 4 degrees C. Further investigation is necessary to see whether these monitoring points are accurately placed or are accurately calibrated.

4.4 Annual Data

Taking into account an estimation of cooling plant energy usage, during the period of September 2010-August 2011, the annual electricity consumption of the office wing was approximately 111.1kWh/m² or 777,457 kWh per year.

The following pie charts show the breakdown of the annual energy usage according to different categories.

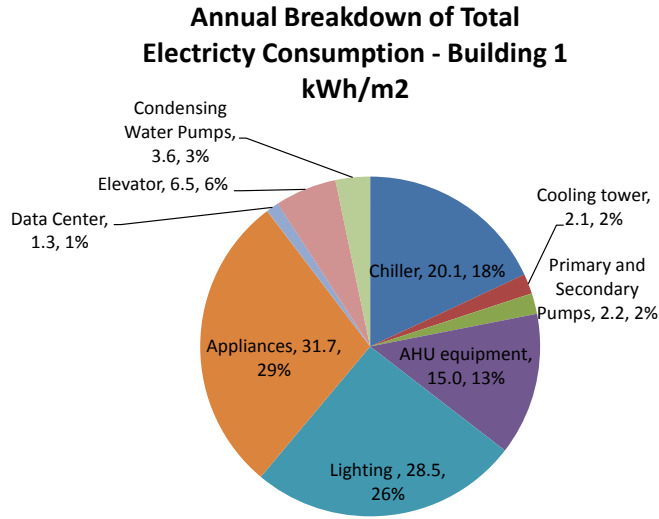

Figure 24: Building 1 total annual energy usage breakdown by end-use.

Total Annual Energy Consumption - Building 1: ISO 12655 [second tier] kWh/m²

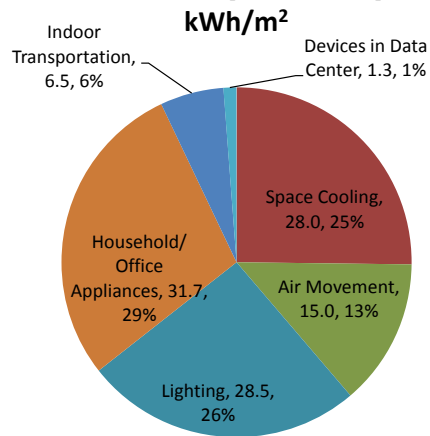

Figure 25: Building 1 total annual energy usage breakdown by end-use according to ISO 12655 standard [second tier]

**Total Annual Energy Consumption - Building 1:
ISO 12655 [first tier]
kWh/m²**

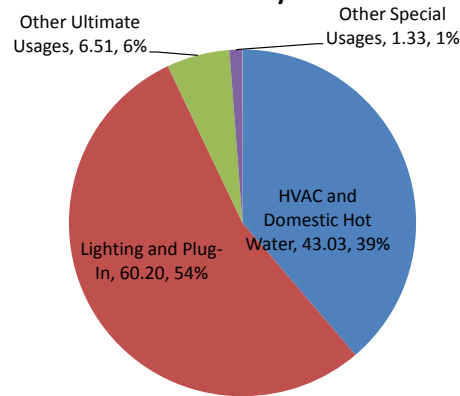

Figure 26: Building 1 total annual energy usage breakdown by end-use according to ISO 12655 standard [first tier]

4.5 Monthly Data

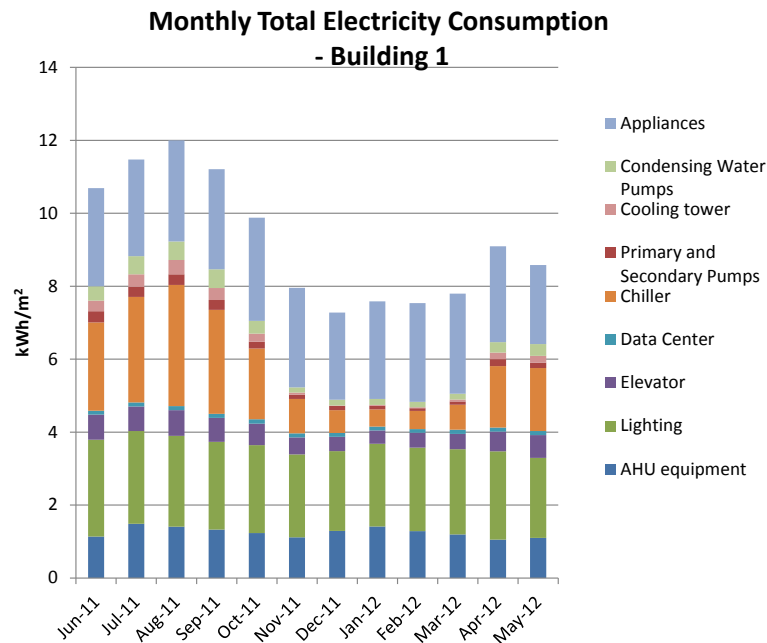

Figure 27: Building 1 monthly electricity breakdown

It is clear that energy usage of the building is higher during the summer months, mostly because increase in energy usage for the equipment associated with air conditioning. The other sub-

categories that are not weather/temperature related, like lighting and appliances, stay relatively constant throughout the year.

4.6 Daily Analysis

Figure 28 shows the total electricity usage difference between weekdays and weekends for the case Building 1. However, it should be noted that it does not include cooling plant equipment, because chiller equipment only runs at night, which would have made the energy consumption increase during the night.

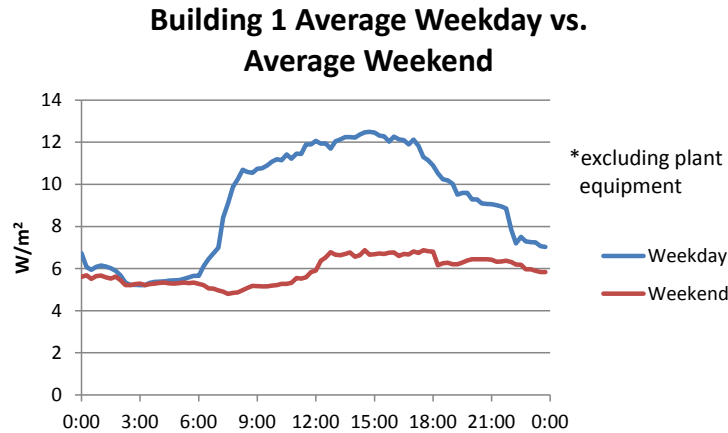

Figure 28: Building 1 average weekday versus average weekend

Note: exclude cooling plant equipment

Unlike both Chinese Buildings A and B, the weekday hourly consumption does not have a dip during the lunchtime break, which means appliances and lighting is still on while they are not necessarily in use.

According to the average weekday energy consumption trend (excluding cooling plant equipment), it looks as if equipment in the building is on from 7:00am to 7:00pm.

Using this operation time period, the average peak-power for weekdays is 11.29 W/m², and the average base-power is 6.81 W/m², 60.3% of peak-power.

For weekends, the average peak-power is 6.03 W/m², while the average base-power is 5.71W/m², 94.7% of peak-power.

4.7 Seasonal Analysis

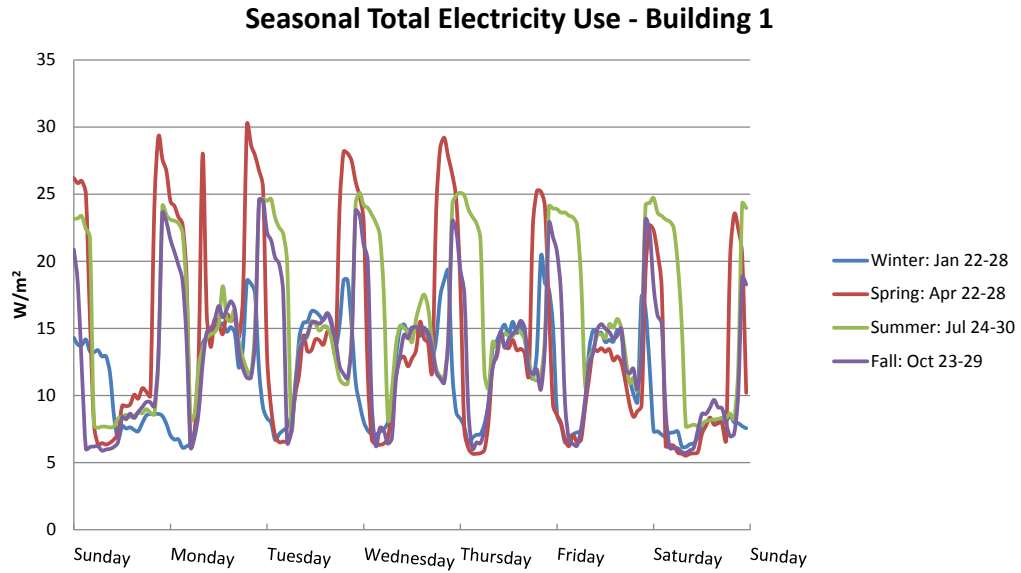

Figure 29: Building 1 seasonal differences in energy consumption

As a result of the special cooling system, there's a large peak at night cause by chillers, cooling towers and pumps in central plant, as well as a lower peak during daytime caused by the other normally operated equipment. As shown in the figure, more electricity was used on spring and summer nights, while much less consumed on winter nights.

4.8 Plant Chiller COP

The average plant chiller COP value for each month was calculated using the following equation.

$$\begin{aligned}
 \text{COP} &= \frac{\text{average cooling load (tonnage produced by plant to tank)}}{\text{average chiller power for specific month}} \\
 &= \frac{\text{flow rate} \left(\frac{\text{kg}}{\text{s}} \right) * C_{p \text{ water}} \left(\frac{\text{kJ}}{\text{kg} * ^\circ\text{C}} \right) * (^\circ\text{C}_{\text{return}} - ^\circ\text{C}_{\text{supply}})}{\text{average chiller power (kW)}}
 \end{aligned}$$

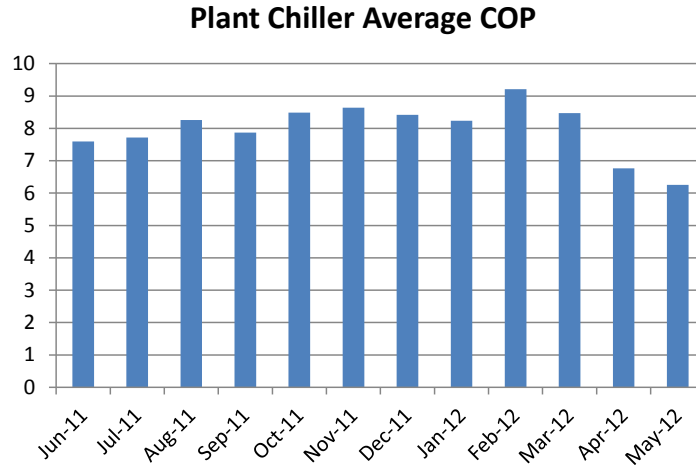

Figure 30: Monthly average plant chiller COP values

The chiller COPs for all these months were very high. One possible reason for this is that the numerator was not necessarily the tonnage consumed by the buildings, but the chilled water sent to the plant’s storage tank.

4.9 Case Study Building 1 Summary

Compared to the average office building in the US, this building uses considerably low energy, and is comparable to the average Chinese building, mainly due to the more efficient lighting and HVAC systems of this building. However, it consumes more in office appliances, consistent with common U.S. office buildings.

In fact, quite a lot of time has been spent on this building trying to clarify specifics in order to make sure analysis methods were correct. This effort could have been avoided if most things were clear to begin with beforehand. In addition, it would be beneficial to get to the source of all the data gaps to make sure that future data that comes from the building does not have as many missing data points.

5. Case Study Building 2

5.1 Basic Information

This building is located in climate zone 3C in California, the United States. It's an old building constructed in 1960, with metal-panel walls without insulation; and leaky, single-pane, clear-glass windows. It is served by various DX (direct expansion) HVAC systems.



Total floor area: 8,316 m²

5.2 Major Data Problems

The raw data exported from the energy monitoring system of this building had a few problems which made specific energy analysis impossible. Some major data problems and corresponding solutions are as follows.

5.2.1 Missing and Negative Energy Data

There exist many data gaps and even some negative data during time series occasionally, involving many sub-items,. Individual missing or negative data may be caused by failure of meters occasionally, while large numbers of continuous missing or negative data may be a consequence of broken or un-calibrated meters for a relatively long time.

In order to get the data in workable order to calculate annual energy consumption, the lost or negative data was replaced by hand with time periods or days that were similar to the invalid points, and weather condition should be taken into account as well. For example, a few missing data would be replaced by previous or following few proper data, or the average of them. Several hours' missing data would be replaced by data of the same time periods on the previous or following day, which needs considering weekdays and weekends respectively. Several days' missing data would be replaced by data of the same time periods from the previous or following week, especially for weekends. The same method goes for missing or negative data of an even longer time.

5.2.2 Calculated points

Some points are calculated based on meters that include various sub-points, and therefore are not actual monitored points, which make it harder to figure out the reason of negative numbers.

For example, the data of “First Floor Lighting”, which is calculated by data from two other points, has some negative numbers for a period of time nearly every day before 04/07/2012, after which there’s no negative numbers any more. With a deep insight into the raw data of these two points, we found the data recorded by meter “Z_Raw - Lighting - Flr1_Ltg - 1070 - 539A1A cct 21 - 00-B0-AE port 1 - FC” was so small that total energy of First Floor Lighting became negative after a series of specific calculation. After 04/07/2012, however, data recorded by this meter became larger suddenly and stay at the new level, which made the total energy of First Floor Lighting keeps positive all the time. It can be inferred that the meter was calibrated or something else was changed in the system. Since the sub-point “Lighting - Flr1_Ltg - 1070 - 539A1A cct 21 - 00-B0-AE port 1 - FC” fluctuates a little and accounts for only a small part of the total energy of first floor lighting, the data before 04/07/2012 could be replaced by the average of data after that day, which contributes to more reasonable total energy of First Floor Lighting.

5.2.3 Irrational Gas Data

According to the raw data, gas consumption of domestic water heater became quite lower and even near zero from the beginning of 2012. This was caused by some certain experiment done with the DHW system of this building, which did some changes to the specific gas meter when finished.

As a common sense, energy use for DHW should be relatively stable throughout a year. Thus, the invalid monthly total DWH gas consumption data should be replaced by the average monthly consumption of September, October, November and December in 2011.

5.2.4 Missing Condition Data

Though environmental and HVAC operating condition data were measured and recorded, there are large amounts of missing data in the database, not only during night, but also in daytime. This leads to significant barriers in energy diagnostics especially for HVAC system.

5.2.5 Rough sub-metering

There are not so many meters in this building. Therefore, the sub-metering is not as specific as that in other case study buildings. There’re three sub-categories in HVAC system, but some of their sub-items are not separated from the total energy of the specific system, which makes it difficult to breakdown the total energy according to standard sub-categories and compare this building with others. For example, “AHU1 & Pump Energy & BL7” consists of an AHU, pumps and an exhaust fan, but can’t be separated. Furthermore, energy for pumps is probably related to heating water and domestic hot water supplying the whole building, which should have been separated from the total loads of this sub-item. “Plug loads” includes too many equipment of different sub-items, such as kitchen, data center appliances, other special equipment, and probably even a small AHU, which may lead to inaccurate analysis.

5.3 Electricity Data Analysis

The analysis in this section is based on electricity consumption of this building, without gas consumption, the heat source of heating water and domestic hot water. However, electricity consumption of some equipment related to space heating, like AHUs and pumps, is included in the total electricity use of the building.

5.3.1 Annual Data

To calculate the annual electricity use intensity of this building, the months of September 2011-August 2012 were chosen. Within this period of time, the annual electricity consumption was approximately 137.5kWh/m² or 1,143,409 kWh per year.

The following are pie charts showing the breakdown of annual electricity consumption of this building.

Annual Breakdown of Total Electricity Consumption - Building 2 kWh/m²

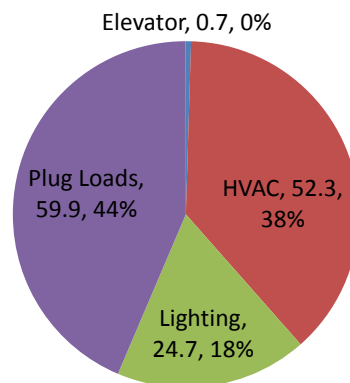

Figure 31: Annual breakdown of electricity consumption of Building 2

According to this pie chart, plug loads consume the most electricity, about 44% of the total, probably because this sub-item consists of too many equipment, such as personal fans, heaters, desktop task lights, and many computers which are left on or stay in standby mode at night for remote access by staff, data backup, operating system and security software updates or other reasons. HVAC and lighting are another two large parts of total electricity consumption, while elevator accounts for quite a little part that can be ignored, which is mainly because there's only one elevator in the four-story building and most staff prefer taking the stairs.

To see more details about HVAC and lighting, we break down the total electricity consumption of HVAC and lighting respectively.

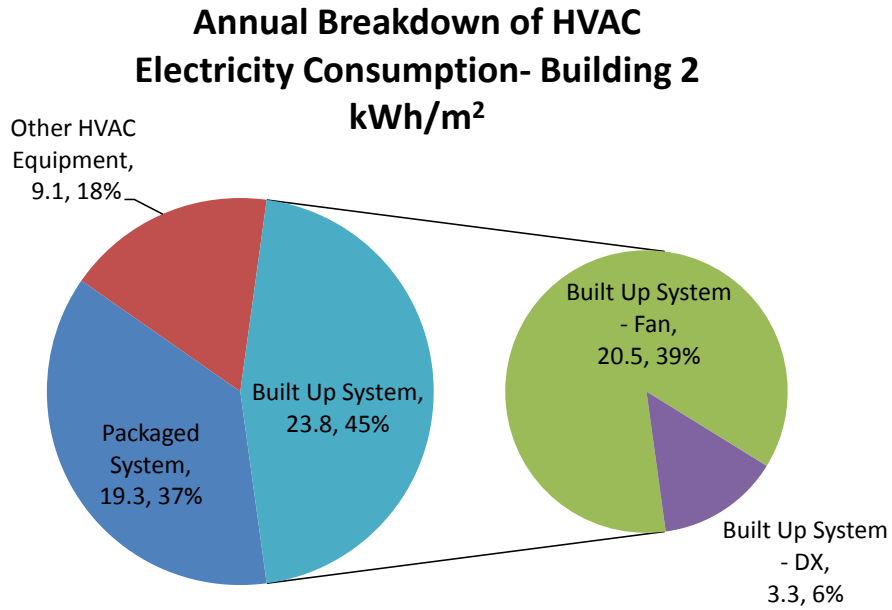

Figure 32 Building 2 annual breakdown of HVAC

Since the sub-categories structure is not so scientific or detailed for HVAC, the HVAC electricity use was broken down into three major sub-categories, namely Built-up System, Packaged System, and Other HVAC Equipment. The built up system is made up of DX units and fans, while the packaged system includes rooftop units, and ductless split units. The last sub-category, “AHU1 & Pump Energy & BL7”, which can’t be easily categorized further based on the given information, is named Other HVAC Equipment in this figure.

As can be seen, built up system consumes the largest amount of electricity. And further inside it, fans account for the major part.

Annual Breakdown of Lighting Electricity Consumption- Building 2 kWh/m²

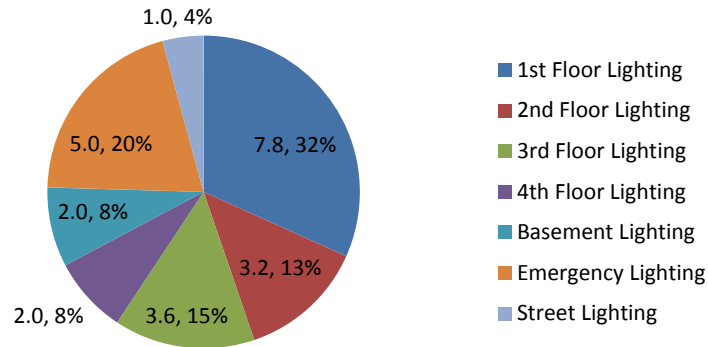

Figure 33 Building 2 annual breakdown of lighting

It's clear that 1st floor lighting consumes the largest part of total lighting energy. But it's abnormal that emergency lighting ranks second in the list, which will be analyzed later.

5.3.2 Monthly Data

Monthly Total Electricity Consumption - Building 2

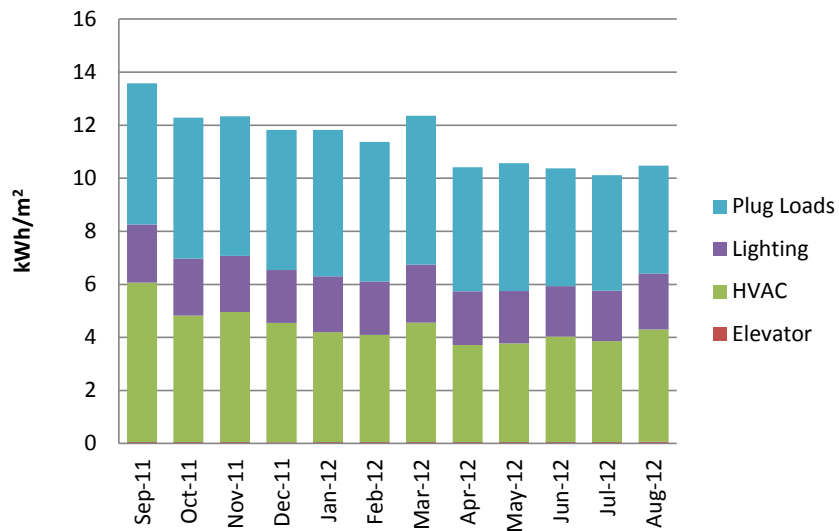

Figure 34 Building 2 monthly breakdown of total electricity consumption

It's clear that energy usage of the building is highest in September, the hottest month throughout a year, mostly because increase in energy usage of HVAC. Lighting, which is not weather/temperature related, stay relatively constant throughout the year.

However, it is curious that the electricity use is higher in March than in the previous and following few months, while electricity use in July and August is much less than in September. This may be because the fourth floor was under retrofit and unoccupied from April to August in this year.

To see more details about HVAC and lighting, we break down the total electricity consumption of HVAC and lighting respectively month to month.

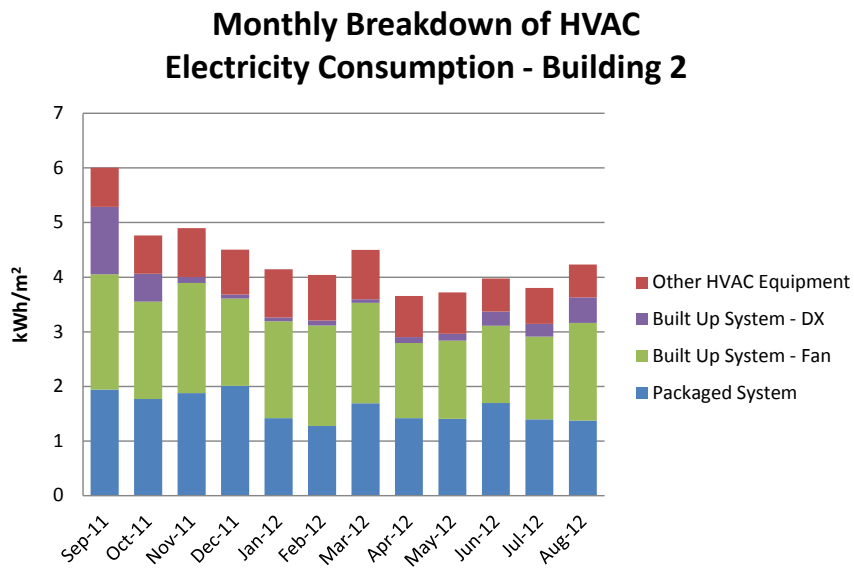

Figure 35 Building 2 monthly breakdown of HVAC

Apparently, DX units consumed much more energy in September than any other months, which contributed to the higher total electricity use in September.

Monthly Breakdown of Lighting Electricity Consumption - Building 2

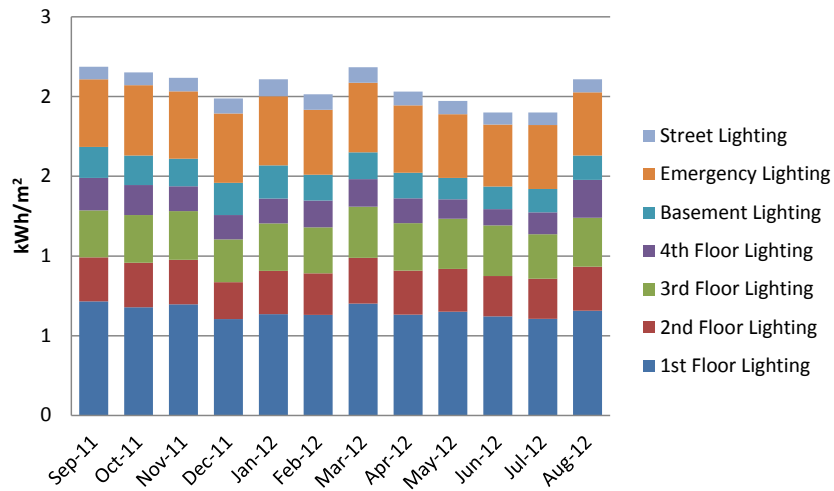

Figure 36 Building 2 monthly breakdown of lighting

According to the above figure, there's no obvious monthly trend in energy use for lighting.

5.3.3 Seasonal Analysis

In order to compare the total electricity usage between different seasons, a typical week was selected from each season respectively, from Sunday to Monday. The load curves of the four typical weeks, based on 15-minute-interval monitoring, are shown as follows.

Seasonal Total Electricity Consumption - Building 2

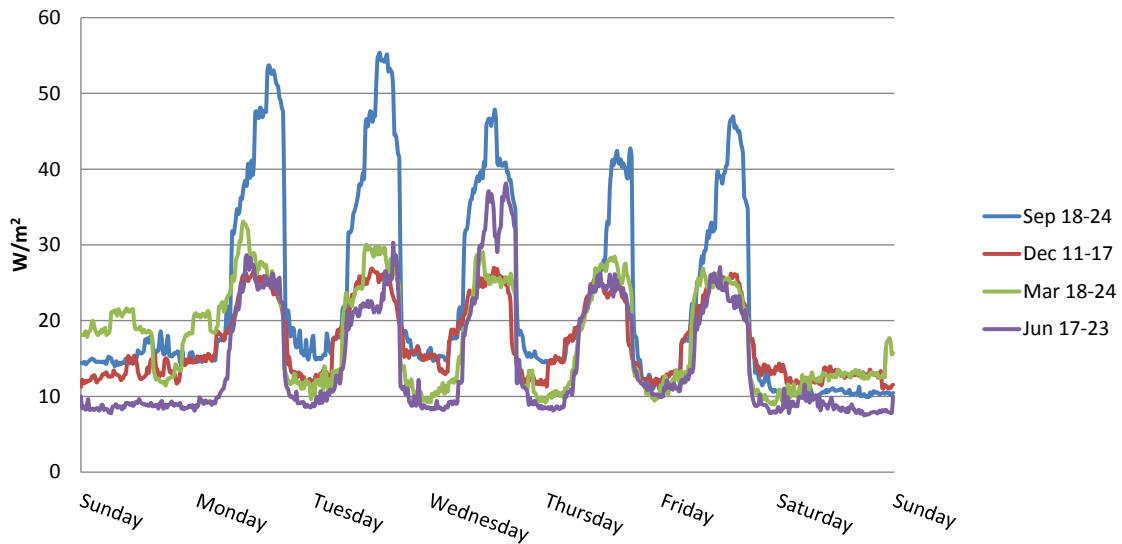

Figure 37 Building 2 seasonal differences in energy consumption

As can be seen, the electricity consumption in a typical week in September is much higher than others, especially for peak loads in daytime. Regardless of September, there's little difference in daytime electricity consumption among other seasons, except a small rise on Jun 20, and a little difference at night. That's mainly due to the relatively stable climate around this building throughout a whole year, except for September – the hottest month, which needs more energy on HVAC.

Therefore, a typical week in September can be used to analyze the weekly trend of electricity use in the hottest season, and a typical week in the other months except September can be used for the other time period.

5.3.4 Weekly Analysis

5.3.4.1 Typical Week in September

According to the analysis above, a typical week in September was selected to analyze the weekly trends in the hottest time period.

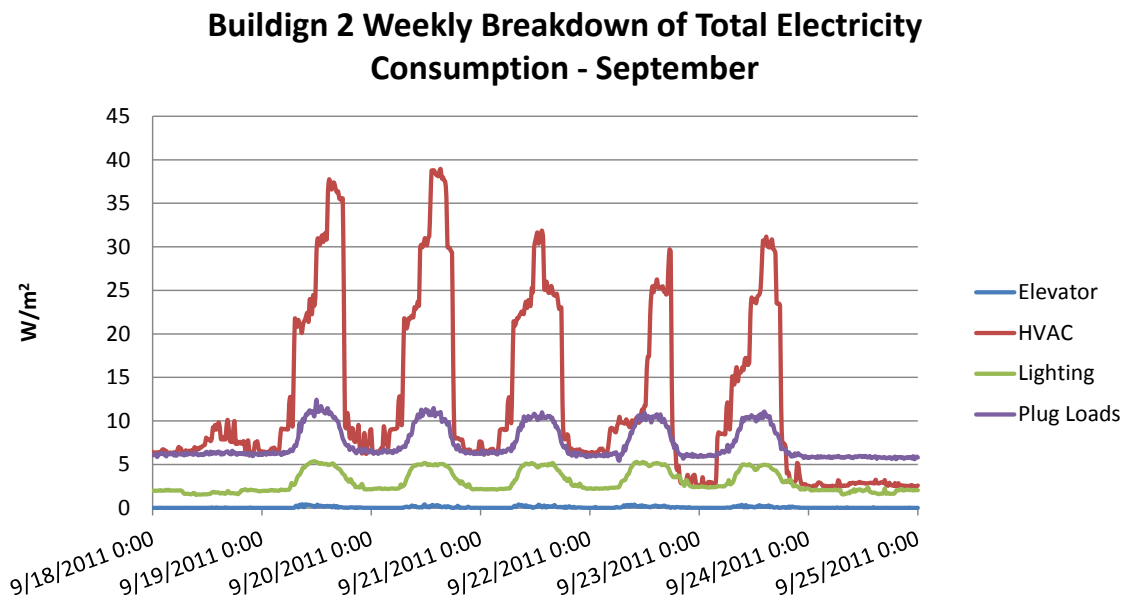

Figure 38 Building 2 weekly breakdown of total electricity consumption in September

It's easy to tell the trend of electricity consumption throughout a typical week in September. Except elevator, the electricity consumption of the other sub-items in the daytime on weekdays is much higher than that of weekends and night, especially for HVAC.

Building 2 Weekly Breakdown of HVAC - September

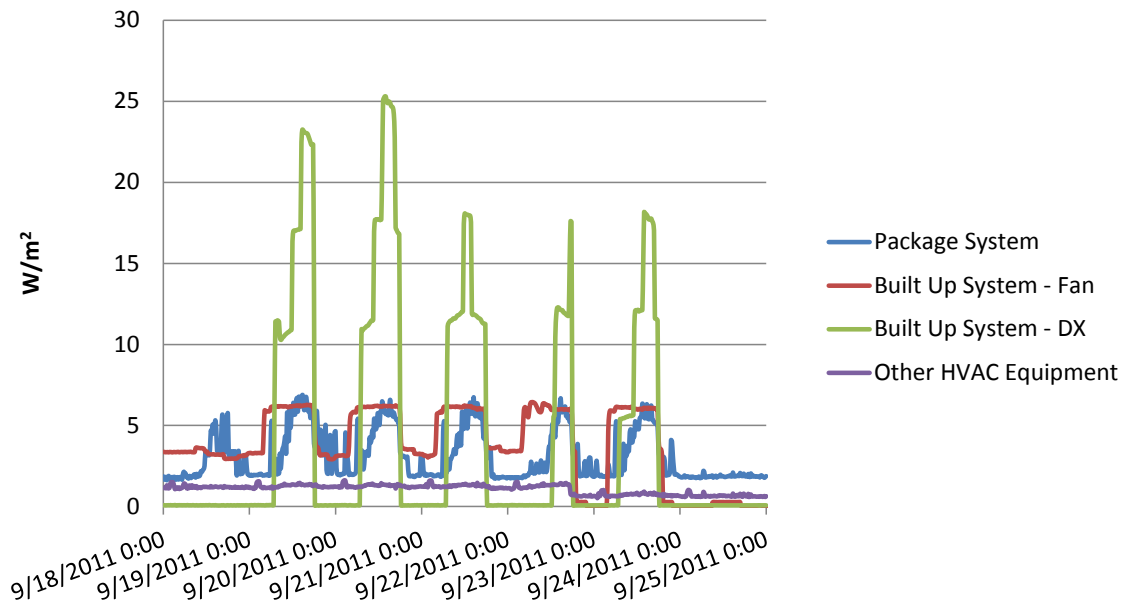

Figure 39 Building 2 weekly breakdown of HVAC in September

During the typical week in September, it's the big rises in "Built Up System - DX" energy use in daytime that mainly caused the rises in HVAC regularly.

For built up system, fans usually started operation a little earlier and worked longer than DX units. Sometimes at night, only fans were functioning at a lower load, while DX units were off. That may probably happen when outside air temperature was low enough for fans to operate alone.

Besides, equipment in packaged system was always on at night, and even had a peak on Sunday, like those on weekdays.

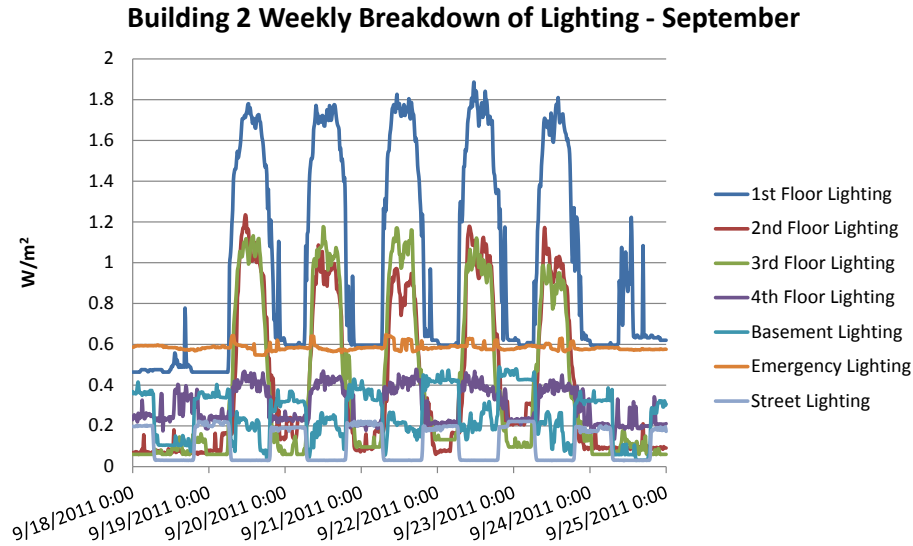

Figure 40 Building 2 weekly breakdown of lighting in September

All sub-items of lighting, except emergency lighting, have the similar weekly trend as discussed before. The fact that emergency lighting keeps a relatively stable level all the time leads to the result of its high energy consumption and contributes to a large proportion of total lighting energy, which was mentioned before. If this sub-item only includes emergency lighting, it seems the equipment for emergency lighting has a really high power, which may need some retrofit. But there's another possible reason, that is, the specific sub-item includes not only emergency lighting but also some other unknown equipment which keep on all the time.

5.3.4.2 Typical week in other months

A typical week in July was selected to analyze the weekly trends in the time period except the hottest month - September.

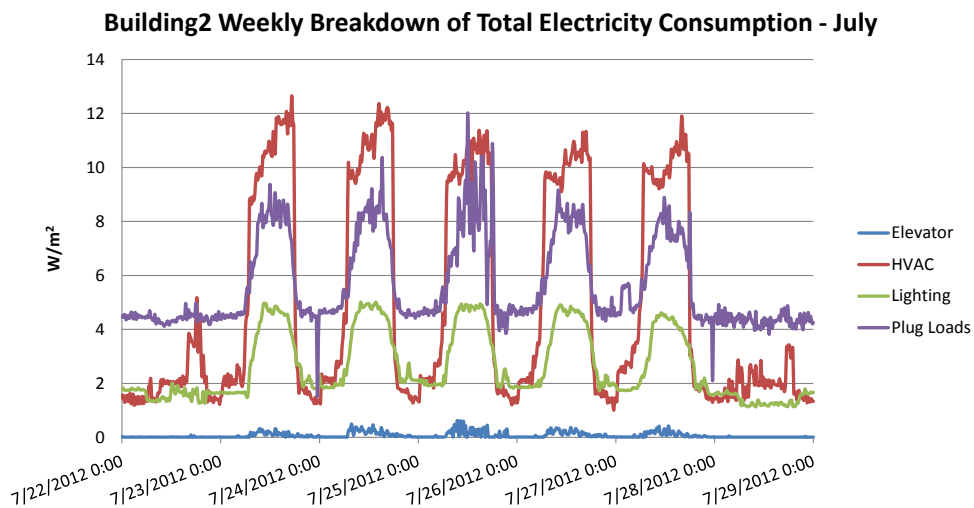

Figure 41 Building 2 Weekly breakdown of total electricity consumption in July

The trends of electricity use in July are similar to those in September. However, the consumption of HVAC is much lower than in September.

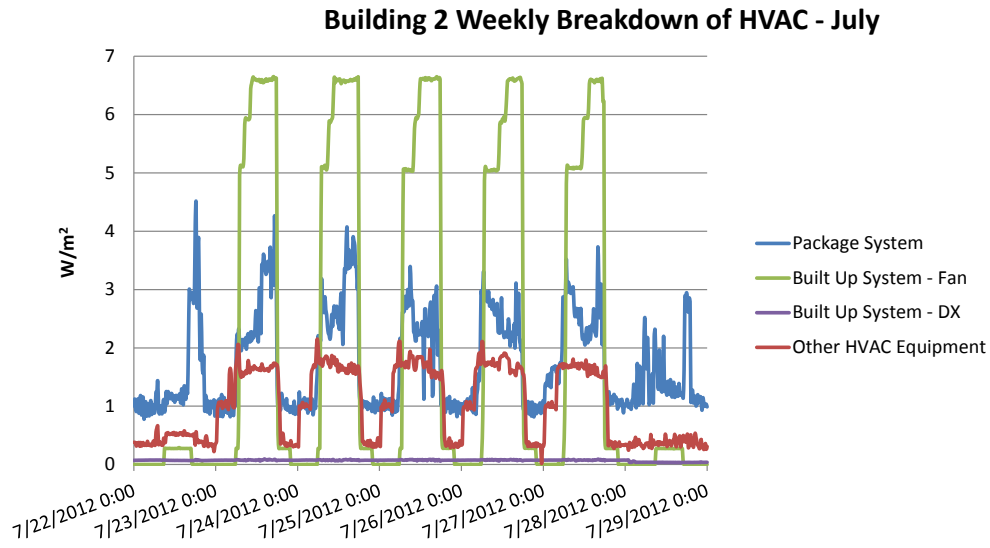

Figure 42 Building 2 weekly breakdown of HVAC in July

Unlike the typical week in September, in July, fans in built up systems were off at night, the base load of package system was lower, and DX units were off all over the week, which indicated lower temperature in July. All of these led to the significant difference between July and September.

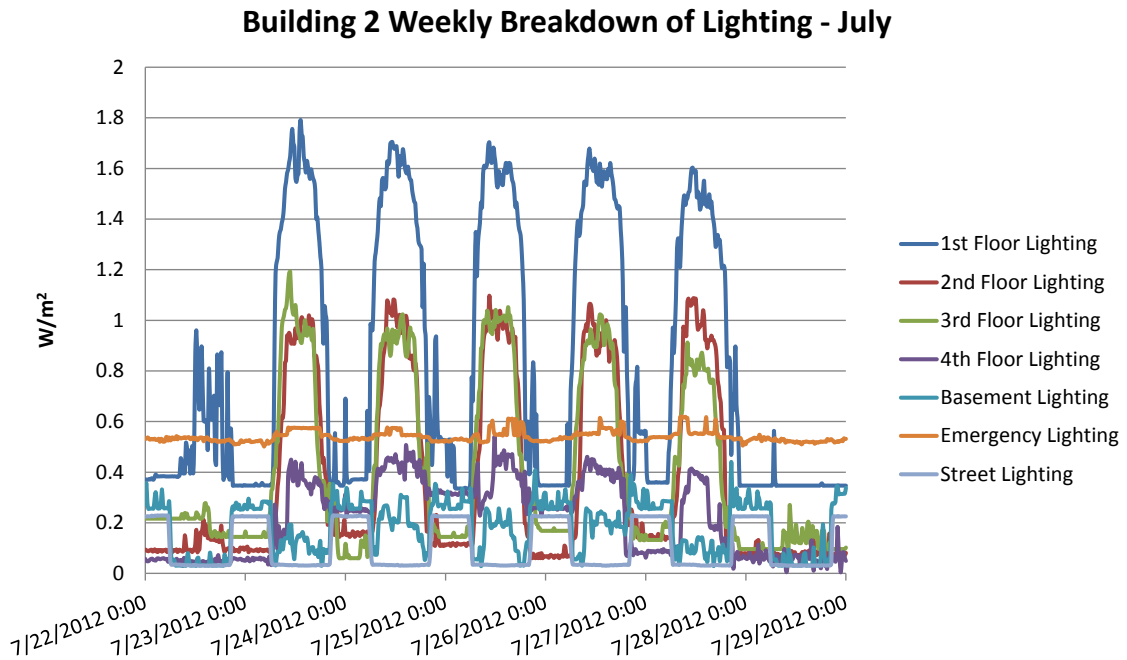

Figure 43 Building 2 weekly breakdown of lighting in July

Trends for lighting were quite similar between the two typical weeks in both July and September, which proved again that energy use of lighting is not sensitive to weather/temperature.

5.3.5 Daily Analysis

Below is a further in-depth look at the trends for daily equipment operation. A weekday and a weekend from September were selected as representatives of typical weekdays and weekends. Though HVAC consumes more electricity in September, the daily trends of most equipment are similar among different months.

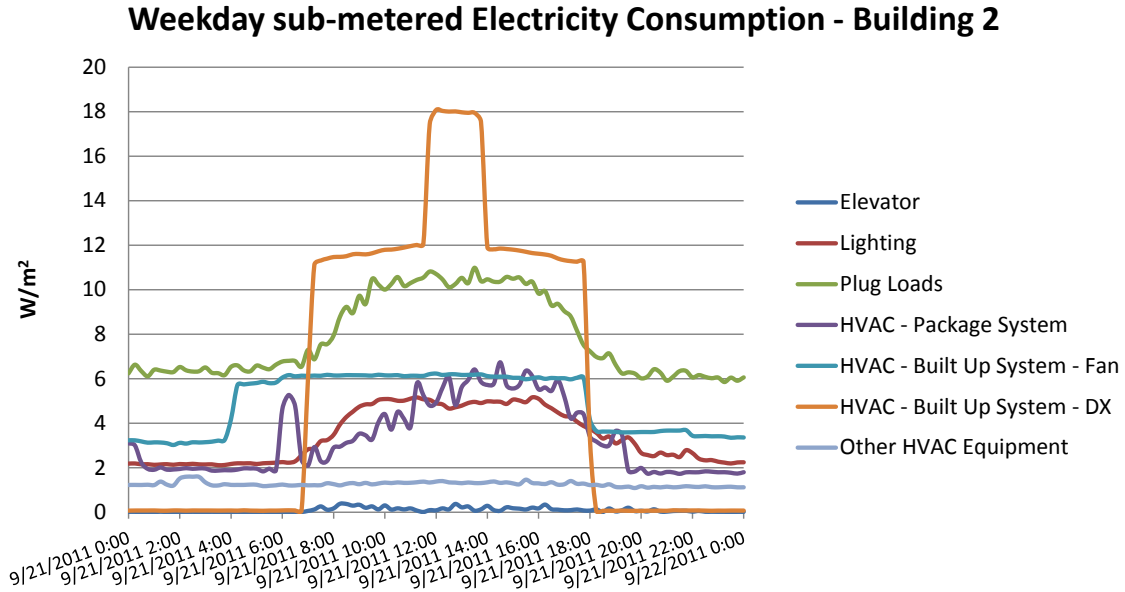

Figure 44 Building 2 typical weekday electricity consumption trend

It can be seen that the energy use of most sub-items starts increasing at around 6:00 (4:00 for fans in built up system) and decreases after 18:00. DX units consume more electricity than other equipment in daytime, and even more at noon. The other sub-items, except elevator, have base loads at night.

Weekend sub-metered Electricity Consumption - Building 2

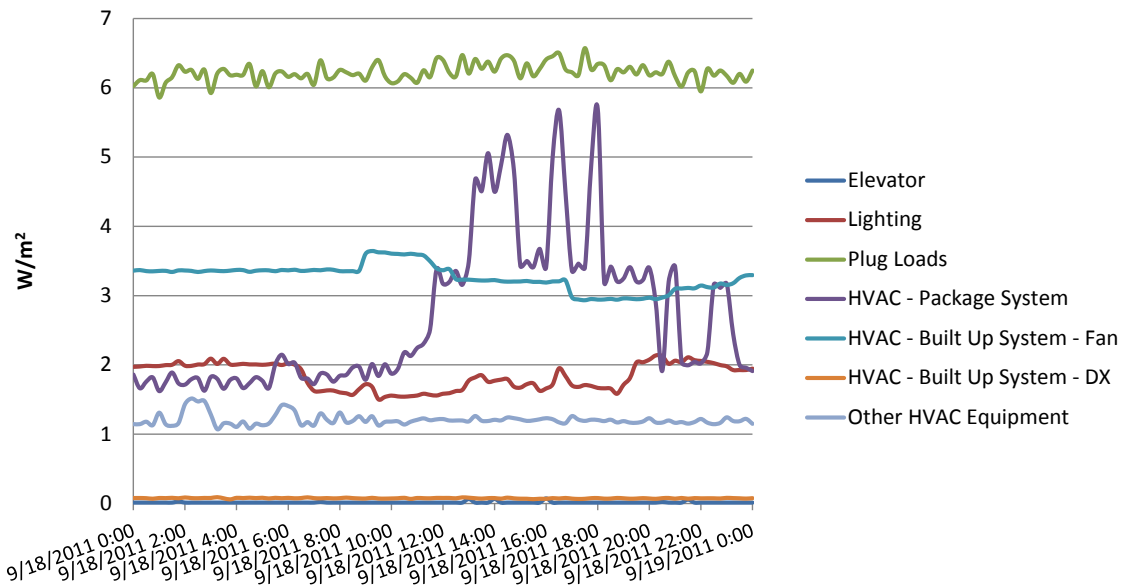

Figure 45 Building 2 typical weekend electricity consumption trend

Though most equipment operates at base loads without big fluctuation at weekends, package system for HVAC still increases electricity use in the afternoon.

The chart below was created by taking averages of daily energy consumption trends of all weekdays and weekends over an entire year.

Building 2 Average Weekday vs. Average Weekend

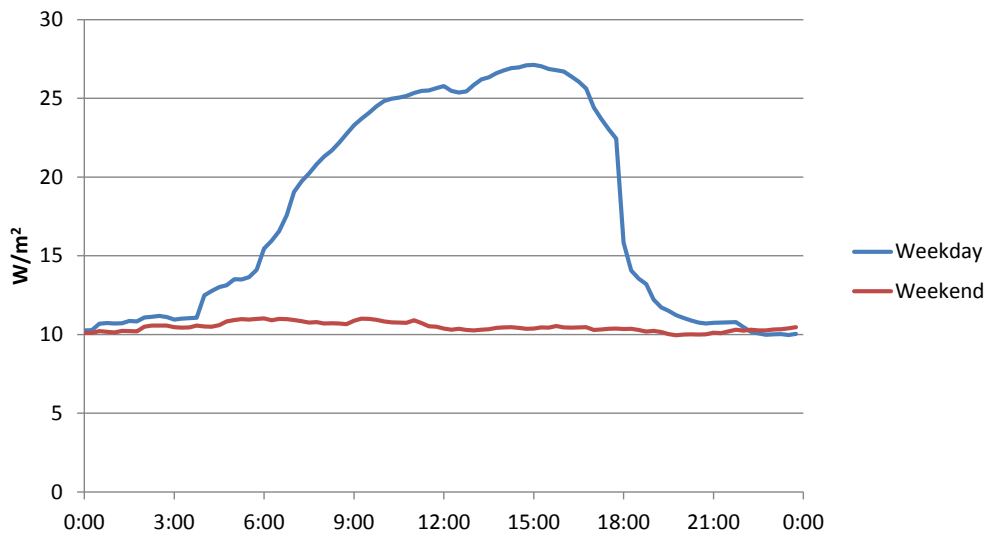

Figure 46 Building 2 average weekday versus weekend total energy consumption

According to the shapes of the energy demand curves and operation hours of the building, it seems equipment operation is mainly on from 6:00 to 18:00.

Using this time period, the average peak demand on weekdays is 23.83 W/m², and the average base load is 11.37 W/m². This means that on average, the base load is about 47.7% of peak load.

For weekends, the average peak demand is about 10.60 W/m², average base demand is about 10.35 W/m², which means the base load is 97.6% of peak load, nearly the same.

When we only consider the instant peak and base load throughout a week, we found that on average, the peak load is about 27.13 W/m², while the base load is about 9.97 W/m². The base-peak ratio is about 36.7%.

5.4 Gas Consumption Analysis

After data correction, mentioned before, the annual breakdown of total gas consumption is as follows.

Annual Breakdown of Gas Consumption -Building 2
kWh/m²

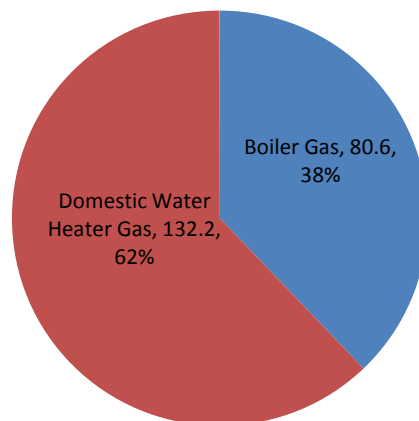

Figure 47 Building 2 annual breakdown of gas consumption

Obviously, gas consumed by domestic water heater accounts for major part of total amount.

The following chart is monthly boiler gas consumption all over a year and DWH gas consumption from September to December in 2011, which use real data only.

Monthly Gas Consumption - Building 2

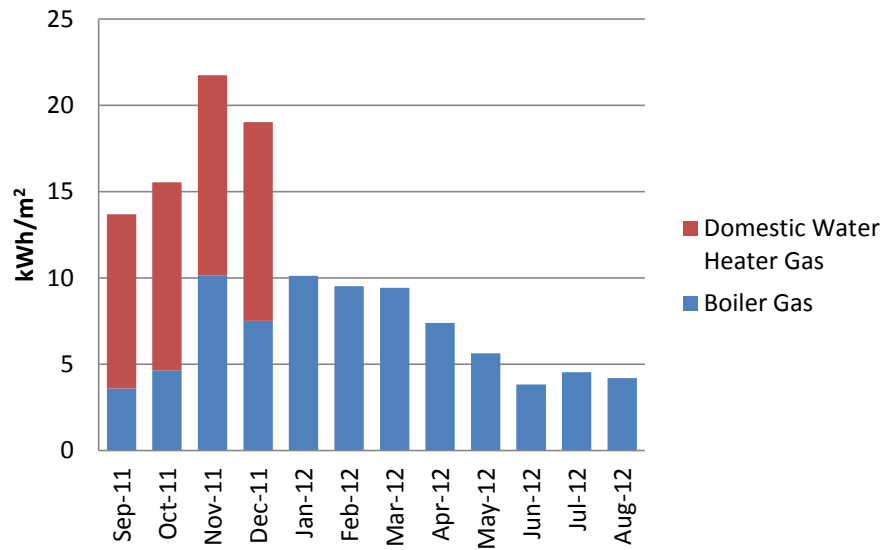

Figure 48 Building 2 monthly gas consumption

Boiler gas consumption changes with months apparently, and was higher in 11/2011-03/2012, except for a decline in December, which was likely to be a result of Christmas holidays. On the other hand, DWH gas stayed nearly the same from month to month, at least in the last four months in 2011.

5.5 Case Building 2 Summary

Old as it is, this building consumes large amounts of energy in HVAC and plug-loads, mainly due to the complex HVAC system, and more office equipment with longer operation hours. However, lighting in this building consumes less energy, mainly because its single-pane windows introduce more natural light, and its lighting system has gone through some retrofit.

Appendix E – Methods and Challenges in Energy Benchmarking between the U.S. and China



Lessons Learned from Benchmarking Commercial Buildings in the U.S. and China: Methods and Challenges

*The U.S.-China Clean Energy Research Center
for Building Energy Efficiency (CERC-BEE)*

The U.S. Team: LBNL + ORNL

The China Team: Tsinghua University

Contents

Introduction.....	2
Required Data.....	3
Building Selection	5
Building Information.....	5
Building Management Communication.....	6
Data Collection and Clear-up.....	7
Data retrieval.....	7
Naming of data points	7
Data Completeness	7
Data quality	8
Data correction.....	8
Data Analysis	8
Analysis methods.....	8
Building Specific Analysis.....	9
Benchmarking Analysis.....	9
Energy Efficiency/Performance Suggestions.....	9
Analysis Challenges	10
Handling District Cooling/Heating Systems.....	10
Building Code Differences in the Two Countries.....	11
Equipment Discrepancies	11
Energy Data Model.....	11
Conclusions: Moving Forward	12

Introduction

Benchmarking methods for commercial buildings has always been a difficult task. Limiting scope and normalizing discrepancies while taking into account case-specific circumstances are all barriers to conducting a useful and proper analysis. However, this task can be made easier with correct data and thorough preparation before data analysis begins.

This report presents some basic methods and challenges in benchmarking, based on real case study experiences from a joint research project under the U.S.-China Clean Energy Research Center for Building Energy Efficiency. The goal of this project is to decode the driving forces behind the discrepancy of building energy use between the two countries; identify gaps and deficiencies of current building energy monitoring, data collection, and analysis; and create knowledge and tools to collect and analyze good building energy data to provide valuable and actionable information for key stakeholders.

The issues are discussed in the order of the steps in the whole analyzing and benchmarking process, shown below. In addition, some suggestions are also presented to try to overcome the existing challenges in the future. It is suggested that all buildings selected for benchmarking in the future take these issues into account before analysis.

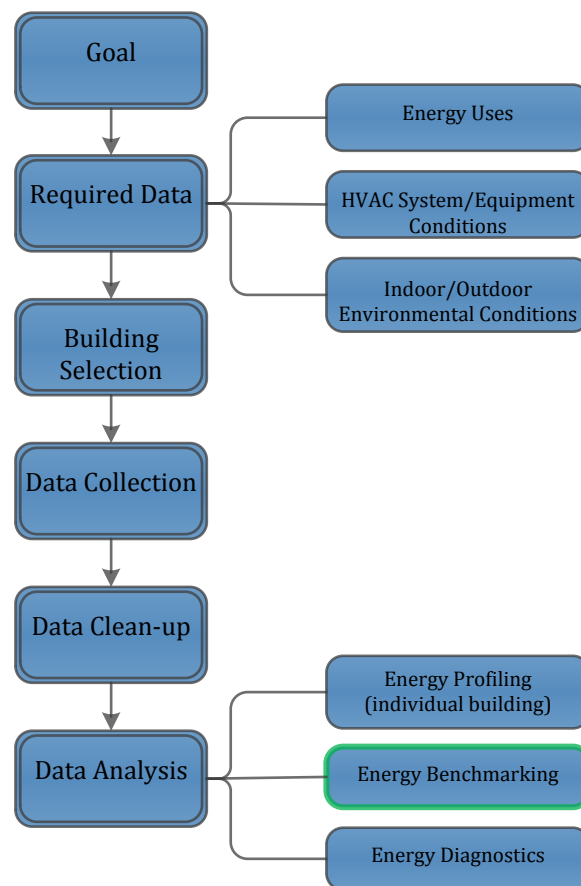

Figure 1: Benchmarking process flow diagram

Required Data

At the beginning of benchmarking task, it's important to know exactly what kind of data is required. To gain a detailed understanding of building performance, measurements included three types of data at one-hour or even 15-minute intervals: (1) building energy use, including building totals and a breakdown into major end uses for various fuel types; (2) operating conditions of HVAC systems and equipment; and (3) indoor and outdoor environmental conditions. Details are as follows.

1. Overview of the monitoring system showing the hierarchy of sub-metering.
2. High-level description of BMS (Building Management System) – what data points are available.
3. Detailed energy sub-metering for major end uses, including lighting, plug-loads, data center and kitchen if any, elevators, service water heating, and HVAC (chiller, boiler, cooling tower, fan, pump, any direct expansion [DX] unit and radiators), etc.
4. Optional but necessary for HVAC analysis and diagnostics: typical HVAC system and central plant (including district system if any) operating conditions. For example, chilled/heating water flow rate, inlet and outlet water temperature; AHU supply airflow rate, supply air temperature, etc.
5. Optional but good to have - indoor conditions including typical space air temperature and humidity;
6. Optional but good to have - outdoor conditions, including outdoor air temperature and humidity, wind speed and direction, solar radiation.
7. At least one complete year's valid measured data at one-hour or 15-minute intervals or even higher granularity.

Note: although raw data are sampled at short intervals by the monitoring systems, such as five-minute or even less, the time intervals of the data available for downloads can be different, depending on what time intervals are used in the post-processing of the raw data. In this project, the post-processed 15-minute interval data were downloaded for the two U.S. buildings, while the one-hour interval data for the two Chinese buildings.

Besides, as shown in the following table, the required data are divided into primary and secondary importance according to their correlation to building energy analysis and benchmarking, and the difficulty in data acquisition. Data of primary importance is imperative and necessary for analysis. Data of secondary importance will allow for more detailed analysis, but might be only used on a case-to-case basis, and therefore will not be necessary for all buildings.

Table 1: Required data description

Data Category	Data Item Name	Description	Importance
Energy Use	Total energy		primary
	Major end uses	lighting, plug-loads, data center and kitchen if any, elevators, domestic hot water, and HVAC (chiller, cooling tower, fan, pump, DX unit and radiators), etc.	primary
	Space heating equipment	boiler and heating water pump.	secondary
	Other specific end uses	other specific equipment	secondary
HVAC Operating Conditions	Cooling system operating conditions	chiller power consumption, cooling loads, chilled water flow rate, inlet and outlet water temperature; AHU supply air flow rate, supply and return air temperature, etc.	secondary
	Heating system operating conditions	supply and return heating water temperature, heating water flow rate.	secondary
Environmental Conditions	Indoor environmental conditions	typical space air temperature and humidity	secondary
	Outdoor environmental conditions	wind speed and direction, solar radiation	secondary

Before complete benchmarking analysis begins on buildings, it is necessary to meet the basic requirement of data, in order to avoid any sort of time consuming recalculation and reorganization of the data, and allow for the data analysis to go through more swiftly.

Building Selection

Building Information

For the purpose of benchmarking, buildings of the same type are selected based on whether or not the most detailed and complete data can be collected. Many buildings do not meet the prescribed data requirement, which limits the selection of buildings for this project.

In order to conduct reasonable analysis and understand building performance better, some building information should be taken into account when selecting buildings. The details of building information required are shown in the following template.

Table 2: Building description template

Category	Item name	Descriptions
Basic Information	Name	
	Location	
	Year of construction	
	Climate zone	
	Type	
	number of floor	
	Floor area (m ²)	
	Conditioned area (m ²)	
	Operation hours	
	Max. Occupancy	
	Building Envelope	Exterior wall assembly
Roof assembly		
WWR		
Window		
Shading devices		
Lighting System	Interior general lighting	
	Interior task lighting	
	Exterior lighting	

	Control system	
	Operation hours	
	Lighting Power	
HVAC	Cooling system	
	Heating system	
	Air system	
	Room set-point	
	Zone	
	Control system	
	Operation hours	
Internal Equipment & others	Plug load equipment	
	Plug load power	
	Transportation systems	
	DHW	
	Energy generation	
Control & Monitoring	EMS	
	Energy Monitoring system	

The items highlighted in the table are of primary importance for basic analysis, while other items are optional but good to have for detailed analysis, according to their correlation to building energy analysis and the difficulty in information collection.

Medium- to large-size office buildings were preferred, as they are the most common types of commercial buildings (referred to as “public buildings” in China). The end uses of such buildings can be more easily clarified as there are not so many special devices or complicated systems as in other building types, such as hospitals. However, if in reality the selected building is a mixed-use building, there must be a way to separate the different types of users (office, retail, library, etc.), for the purpose of correct benchmarking.

Building Management Communication

Building owners’ willingness to share data is another challenge. Many owners are worried about privacy and security issues concerning real-time data. This challenge could be overcome by

personal discussions with facility managers, site visits, nondisclosure agreements, and by the promise to share analysis results and identify retrofit measures. Building owners must be convinced of the benefits of such a project for energy savings.

Building management has a large influence on the energy performance of a building, as it determines the operation of energy consuming equipment in the building. From error/fault detection and correction to operating hours, building management can be the difference in energy efficiency versus energy waste. However, in our experiences, some building managers, who are not particularly familiar with the researchers, seemed busy and communication with them was slow, indicating that these sorts of projects were not on their high priority list. In some cases, communication must go through the energy monitoring company or through a government mandate.

It is important to communicate with building managers before the project actually starts in order to let them know their responsibilities and what kind of information they may be asked throughout the monitoring process.

Data Collection and Clear-up

Obtaining valid, detailed and useful data is by far the largest barrier for benchmarking and monitoring energy usage of commercial buildings in general. Much of the experiences that we encountered had some data problems, revealing the prevalence of data problems.

Data retrieval

When database access is allowed, it is still a labor-intensive procedure to download and export data to researchers' computers. Some systems need certain computer language to retrieve and export the data of every useful data point respectively, which can take a long time. Moreover, downloaded dataset may change a little without being noticed when the same operation is conducted repeatedly.

The difficulty and reliability level of such work depends on the technical features of the energy-monitoring system. Improvements to data retrieval, downloading, and exporting features would ease data acquisition and result in fewer manual errors.

Naming of data points

The benefits of consistent and useful data point names in energy monitoring system are becoming more apparent as computerized systems containing hundreds or thousands of points are deployed in commercial buildings. Well-chosen point names can provide useful information about installed systems and make it easier to monitor, retrieve and download, analyze, maintain, modify, and interconnect data of various building systems.

Data Completeness

Most of the selected buildings have some missing data, and there seems no pattern to which meters might lose data during what time periods. The causes of missing data vary.

For American buildings, there was a higher frequency of missing data around weekends, suggesting that when building managers are not present, energy performance may not be optimized. Aside from data losses on weekends, there seemed to be no pattern to which meters would lose data during what time periods.

For Chinese buildings, most of the problem lies in the connectivity between meters, database and online system. When connectivity is lost, all data is lost for all equipment.

Meter instability may cause occasional individual missing data, while large sets of missing data may be caused by the retrofit of either the monitoring system itself or energy service system (like HVAC or lighting), or even by power failure in the buildings, during which the meters don't measure, the connection is lost, and even the computer is out of power, leaving missing data in the database. To avoid these problems requires higher quality meters, sensors, nonstop operation of the monitoring system, and better emergency measures when power is out and connection is lost.

Data quality

Even if the data obtained are complete, data quality may suffer, mainly due to the un-calibrated or broken meters or sensors. Some invalid data — such as negative values and abnormally mutational findings — can easily be detected, while some seemingly normal data may actually be inaccurate, considering the error of measurement. Higher quality meters and sensors, along with more frequent maintenance, would avoid these problems.

Moreover, it is possible for invalid data to appear during the downloading and exporting process, especially when exporting a large set of data at one time. A higher quality data transmission system may avoid this possibility.

Data correction

To get the data in workable order for calculation, analysis, and benchmarking, the missing or invalid (mainly negative) data should be replaced with data during time periods or days that were similar to the invalid points, taking weather condition into account as well. For example, a few missing data would be replaced by the previous or following few proper data, or their average. Several hours' missing data would be replaced by data of the same time periods on the previous or following day, taking into account weekdays and weekends. The same goes for missing or invalid data of an even longer period.

Data Analysis

Analysis methods

The analysis methods considered in such a project are as follows, separated by high and low priority based on their correlation to this project and whether or not sufficient or useful data can be collected to undergo analysis. Most of these methods was adopted from "Energy

Information Handbook: Applications for Energy-Efficient Building Operations”, prepared by Lawrence Berkeley National Laboratory in 2011.

Building Specific Analysis

High priority

- Total Annual/Monthly/Daily Energy usage per square meters of all the equipment listed of high priority in “Required Data” section.
- Working days vs. non-working day (holidays, weekends) analysis
- Peak-/base- load analysis

Low priority

- Operating factors/indexes/metrics: Chiller COP analysis, water transportation factors (chilled water), and energy efficiency ratios.
- Total Annual/Monthly/Daily Energy usage per square meters of all the equipment listed of secondary importance in “Required Data” section.
- Specific equipment analysis
- Day-lighting (cloudy vs. sunny days)
- Per occupant analysis
- Free cooling from economizers

Benchmarking Analysis

High Priority

- Performance compared to average of similar type of building in both the U.S. and China
- Performance compared to other buildings in analysis portfolio

Note: Because of the lack of indoor/outdoor information for Chinese buildings, weather normalization across buildings may be difficult. Lighting can be used as a simple metric to do preliminary comparisons, as lighting is less dependent on weather and more dependent on building management/occupancy.

Energy Efficiency/Performance Suggestions

High Priority

- Suggestions for building management practices
- Suggestions for equipment retrofits

Table 3: Summary of information and analysis with priorities based on equipment, building, and benchmarking levels

Item name		Equipment Level Primary Importance	Equipment Level Secondary Importance	Building Level	Benchmarking Level
Energy Use (per square meter)	Annual	high	low	high	high
	Monthly	high	low	high	high
	Daily	high	low	high	high
Analysis	Working vs. non-working day	high	low	high	high
	Peak/Base load analysis	high	low	high	high
	Day-lighting analysis	low	low	low	low
	Per occupant	low	low	low	low
	Free cooling	low	low	low	low
	Comparison to other buildings in portfolio	high	low	high	high
	Comparison to similar buildings in respective country	high	low	high	high
Energy efficiency suggestions	Operating metrics, indexes, factors	high	low	high	high
	Building management	high	low	high	high
	Retrofits	high	low	high	high

Analysis Challenges

Handling District Cooling/Heating Systems

District systems are common for heating for Chinese buildings or buildings that are part of a campus network for American buildings. Thus, energy data specifically for individual buildings are unavailable.

When handling a building that is connected to a district cooling/heating system, in order to include the related energy in analysis, it is necessary to calculate the ratio of cooling/heating load consumed by the building to that supplied by the plant. Multiply this ratio by the energy

consumed by the plant in order to get a rough estimate of the building's energy consumption associated with heating/cooling.

Building Code Differences in the Two Countries

Each country has its own standards for building operation which makes it difficult to compare whether or not a given building from one country is operating efficiently compared to a given building in the other country. For example, base loads and peak loads of lighting may be different due to lighting standards, and air handling unit energy may be more or less depending on ventilation standards.

Equipment Discrepancies

Each building also has its own specific systems that may be difficult to compare across one another.

The most common equipment discrepancies are:

- District heating/cooling
- Decentralized vs. Centralized conditioning
- Other cases (storage tanks for district cooling, etc)

Energy Data Model

After data collection and clear-up, it is necessary to analyze energy usage based on different end uses. However, in each country and even each building, the placement of the data meters is different, lacking a uniform and standard sub-metering model. Thus, sometimes it is hard to categorize and compare energy use by end uses completely.

As a solution, a model structure was developed in this project, shown below, which generally follows the building energy use model in the ISO Standard 12655. Considering the wide use of electricity in the case study buildings and the technical difficulty of gas and water sub-metering, especially the lack of district heating measurement in China, only electricity is considered, which distinguishes our structure slightly from the ISO model approach.

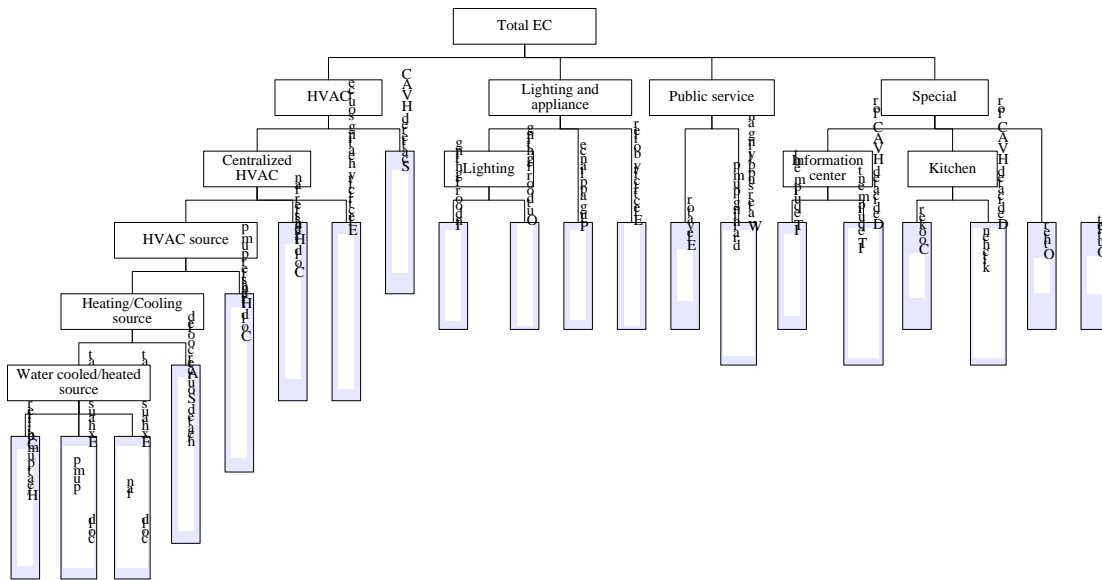

Figure 2: Building electricity sub-metering model

The electricity end use model follows a tree structure, from total energy use down to each terminal device. HVAC, lighting and appliances, public services, and special are defined as the first subclass. The detailed sub-items' classification for each main component are defined step by step. The model contains 31 nodes. Except for the outlet node, 19 basic nodes indicate a certain kind of equipment, and 12 are composite nodes. The model has a clear structure and logical relation between each sub-item. It can be used in most types of large-scale commercial buildings, including office towers, hotels, and shopping malls, and thus making benchmarking relatively easier.

Conclusions: Moving Forward

Important Future Requirements

The largest barrier for benchmarking is data completeness. Since both China and the U.S. collect different data for building energy analysis, it is important to have the most detailed information possible. Moving forward, it is important that the two countries keep in mind the following for every future case study and benchmarking effort:

United States:

- Improve quality of data;
- Install more meters for more specific sub-metering

China:

- Install meters for environmental conditions and HVAC operating conditions;
- Try to add district heating information and collect related data;

- Collect data at 15-minute time intervals.

Both Countries:

- Involve building managers in projects;
- Improve communication with other respective country.

Given the different cases we have experienced in buildings in both the U.S. and China, it is imperative that analysis methods and data collecting are standardized so that proper benchmarking may continue smoothly in the future. It is advised that before buildings can be catalogued into the benchmarking portfolio, that all the suggestions for overcoming challenges be taken into account. In addition, researchers from each country must pay attention to what additional data must be collected before actual analysis in order to maximize benchmarking efficiency.

With proper data, conclusions may be drawn on the fundamental differences between the U.S. and Chinese buildings, and what they may learn from each other. Building benchmarking is an important tool for monitoring energy performance of buildings so that we can achieve a common goal of greenhouse gas reduction.